

# "49'er Availability"

by [Doug Hendricks KI6DS](#)

---

There have been several inquiries as to the availability of the 49er kits. NorCal was given the rights to produce the 49er by Wayne Burkick, N6KR. He designed it as a simple project for the 1996 Dayton Building contest, never dreaming that it would become so popular. Wayne did not spend a lot of time with the design, and it had several shortcomings. It did work, and many mods were made to the circuit to improve it. But, it was not intended to be an ongoing kit. Last November Wayne asked us to stop producing the 49er, as he felt that it had run its course, what with the advent of the 38 Special, and the new SST, there were kits to take the place of the 49er that were much better circuits and designs. We agreed to that, as we should. Then, Dave Ingram wrote a very nice article about the 49er for CQ magazine, that was not published until Feb. of this year. Dave has no control over the lead time of the magazine, nor did he know that we were discontinuing the production of 49er kits. Thus, due to bad timing, the article came out after the demise of the 49er. The orders for the 49er poured in to Jim Cates, and Jim had to return every order with a letter of explanation. This was added to his already huge job of handling 38 Special orders and regular NorCal business. Dave also made a mistake in the pricing of the back issues of QRPP, but that is another matter.

There will not be anymore 49er kits. The circuit is copyrighted by Wayne Burdick, and he does not wish to have anyone produce kits. It is NOT in the public domain, even though it has appeared in print, QRPP, QRP Quarterly and CQ. The artwork for the PC Boards was done by me, and I hold the copyright to that. Again, it is NOT in the public domain, and may not be reproduced without my permission other than copies for personal use. I was asked by Wayne to not produce any more boards, and I have honored his request.

So, for all of you who are asking, No, there will not be any more 49er kits. Its time has come and gone. There are now new kits to satisfy the building urge. Of course, you are free to build the circuit ugly style, or to make your own board from the artwork that was published, but you are not allowed to produce boards for sale from that artwork. Please honor Wayne's request. It is the honorable thing to do.

We are very fortunate in the QRP world today to have so many designers sharing their work with us. But, please, please honor their copyrights. If we don't, they may not wish to be so share conscious in the future. Dave Benson, Roy Gregson, Dick Witzke, Wayne Burdick, Ori Mizrahi-Shalom, Bruce Williams, Dick Syzmanski, Rick Campbell, Rick Littlefield and others have graciously been very open with their circuits and designs. Please do not do anything to tilt the delicate balance that we now enjoy.

# 49'ER SCHEMATIC

## Product Det./VXO Low-Pass Filter/Mute

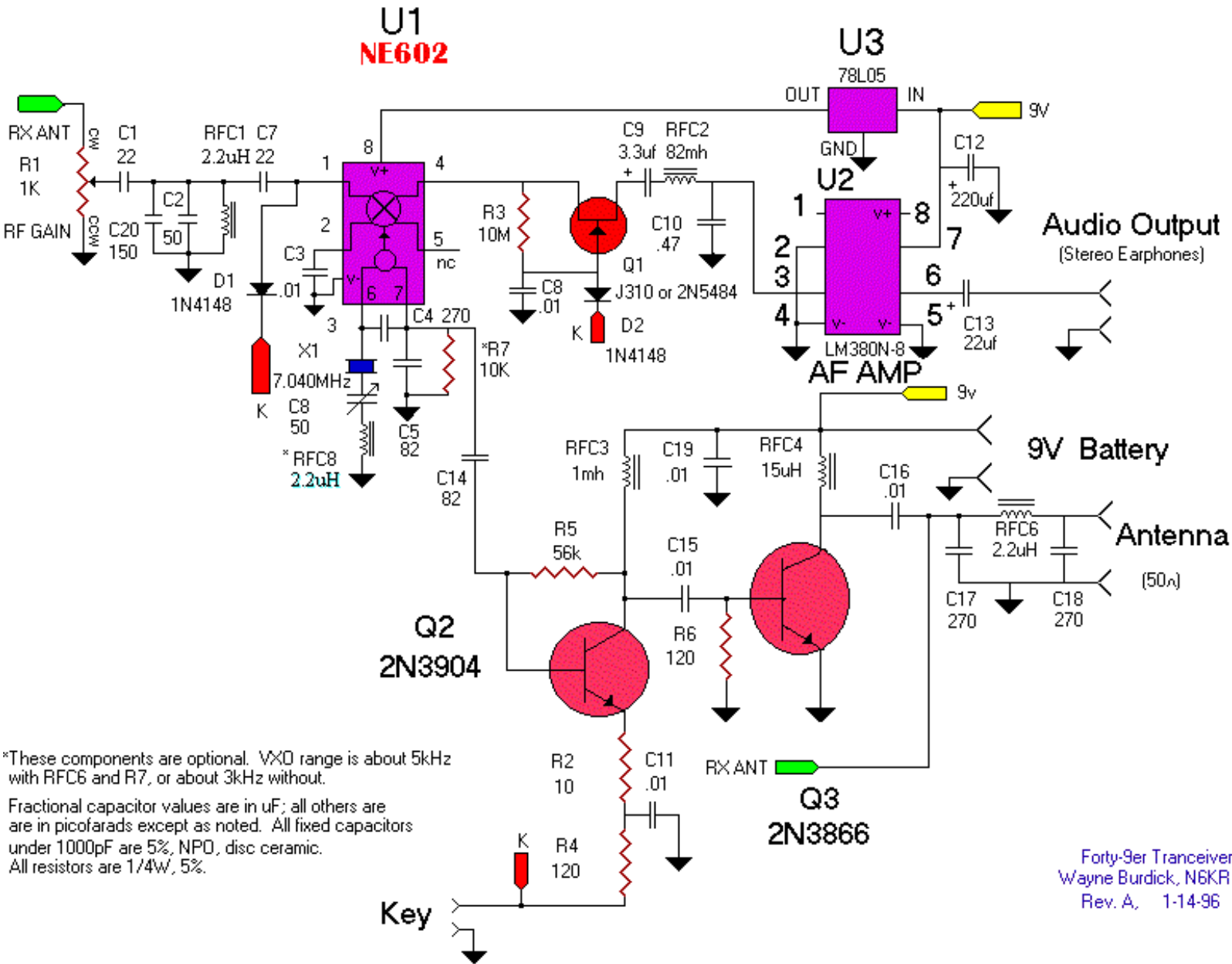

\*These components are optional. VXO range is about 5kHz with RFC6 and R7, or about 3kHz without.  
 Fractional capacitor values are in uF; all others are in picofarads except as noted. All fixed capacitors under 1000pF are 5%, NPO, disc ceramic. All resistors are 1/4W, 5%.

Forty-9er Tranceiver  
 Wayne Burdick, N6KR  
 Rev. A, 1-14-96

# 49er Mods

Compiled by Doug Hendricks, KI6DS

Internet formatting Gary Hanson, KJ5VW and Jerry Parker, WA6OWR

The 49er 40 meter direct conversion transceiver was designed by Wayne Burdick, N6KR as a platform or framework for the building contest at the ARCI Annual Meeting at Dayton. It was never intended to be a finished product, but was designed as a starting point for experimentation and learning. It was successful beyond our wildest dreams. Here is a collection of mods that were sent to me by the various authors. They are presented here so that you may share in the information discovered by our members. Permission is granted to reprint this information in any club journal or newsletter provided that credit is given to QRPP and the various authors, and that the newsletter or publication is nonprofit. No one may reprint this for profit. If you reprint it, credit it to QRPP, June 1996. Thus, for the first time ever, I am previewing an article on the internet.

## Table of Contents

Click on this Title to find the article	Contributor
<a href="#">Debuging the 49er Receiver</a>	Ori Mizrahi, AC6AN
<a href="#">LM380 Audio Boost Mod</a>	Paul Harden, NA5N
<a href="#">40-9er history and Comments</a>	Wayne Burdick, N6KR
<a href="#">Sub the LM386 for the LM380 in the 49er</a>	Wayne Burdick, N6KR
<a href="#">Putting the 49er in an Altoids Case</a>	Stan Wilson, AK0B
<a href="#">My Mods to the 49er</a>	Larry East, W1HUE/7
<a href="#">Improved audio filtering for the 40-9er</a>	Ori Mizrahi, AC6AN
<a href="#">Power "Switch" for the 49er</a>	Ori Mizrahi, AC6AN
<a href="#">Simple Power Supply Instability Fix</a>	Ori Mizrahi, AC6AN
<a href="#">40-9er Correction: Receiver Input Tuned Circuit</a>	Wayne Burdick, N6KR
<a href="#">Case for the 49er</a>	Robert Capon
<a href="#">The Altoid Oreo 40-9er</a>	Floyd Smithberg, NQ7X
<a href="#">40-9er Alignment and Output Power</a>	Ori Mizrahi, AC6AN
<a href="#">Choke Your 40-9er, Now!</a>	Wayne Burdick, N6KR
<a href="#">40-9er Self Oscillation Fix</a>	James L. Jendro, K8WVG
<a href="#">40-9er "Tweaks" and Tips</a>	Larry East, W1HUE/7

<a href="#">40-9er success!</a>	Mike Hagale, AC6JA
<a href="#">49er Battery Mod</a>	John, N5INZ
<a href="#">Solving Two 40-9'er Problems with One Mod!</a>	Alan Kaul, W6RCL
<a href="#">49er Measurements</a>	John, WB4OFT
40-9er Harmonics	Al Moyle, N3KFL
<a href="#">49-er Performance</a>	Alan Kaul, W6RCL
<a href="#">40-9er Power Drop W/1K</a>	Wayne Burdick, N6KR

## Debugging the 49er Receiver

by Ori Mizrahi, AC6AN

[mizrahi@svlhp8.scs.philips.com](mailto:mizrahi@svlhp8.scs.philips.com)

The 49er is simple enough to write almost a complete test procedure, so here it is: Debugging the 49er Receiver.

The debug procedure for the receiver involves going through the schematic and checking the RX signal path from the inputs of the LM380 backwards. Listen to it and touch the appropriate pins with some wire - a resistor lead works just fine. If you can hear some "scratching" - the signal path is most likely OK from this point to the headphones.

Before running this test, let's check the obvious first:

- \* Are the headphones OK?
- \* Are they compatible with the socket in use?

If this is fine, proceed with electrical debug. First check all the supply voltages:

- \* LM380 pin 7 = 9V (depends on battery or supply in use)
- \* NE602 pin 8 = 4.7-5.3V

Check the ground connections with an ohmmeter to the supply ground, no more than a fraction of an ohm is acceptable:

- \* LM380 pins 2,4,5
- \* NE602 pin 3

If you have another receiver then this is an easy step: NE602 Oscillator: oscillator circuit defective? "Sniff" the oscillator with another receiver: tune between 7.035-7.045 with a short wire as an antenna for

the other receiver very close to the (powered) 40-9er board. If nothing is heard - debug the oscillator circuit.

Next follow the receive signal path, using the procedure described above, in this exact order:

<b>* Test point</b>	<b>What to do if no sound</b>
1. LM380 pin 3	Check the LM380 supply, pin connections, etc. Possible cause: bad LM380?
2. RFC2-C9	Check across RFC2 with an ohmmeter, a few hundred ohms is acceptable - Possible cause: bad RFC2?
3. Q1(drain)-C9	Possible cause: bad C9?
4. NE602 pin 4	Check pins of Q1, check voltage on gate of Q1 in RX
5. NE602 pins 6,7	Oscillator circuit defective? Skip this step if you already verified the oscillator is working.
6. NE602 pin 1	Check D1 for short, some short between ANT and pin 1, if all OK - bad NE602?
7. ANT	RX ANT not connected to this point? Bad R1?

If all the above looks fine, you have to deal with the worst problems:

\* NE602 oscillates at VHF frequencies

\* Some intermittent (Good Luck!)

\* Bad solder joint - hope you didn't build it tight and "ugly" like me (took some time to find those fine shorts)

73 DE ORI AC6AN

Return to [Table of Contents](#)

---

## **LM380 Audio Boost Mod**

**Paul Harden, NA5N**

[pharden@aoc.nrao.edu](mailto:pharden@aoc.nrao.edu)

Here is the easy mod to boost the audio out of the LM380 significantly. Just breadboarded it up and it works great. 3 parts, and I know you can fit them in your Sucrets box. I would really recommend making

it a permanent addition to the 49er. Well worth the extra 2-3 components.

Here is the positive feedback modification for the 40-9er to boost the audio output from the LM380 ... breadboarded and tested only moments ago. It works, and works great. Measurements based on my 14-pin LM380, but should be virtually identical to the 8-pin LM380.

#### MODIFICATION STEPS FOR THE 49er:

1. Remove power (hey, all instructions always start with that one. You don't wanna get knocked on your butt from that 9v battery!)
2. Cut trace on LM380 to isolate pin 2 (+IN) from ground.
3. Solder 15K resistor on LM380 from pin 2 to pin 4 or 5 (ground).
4. Solder 1Meg resistor from (-) side of C13 to LM380 pin 2.
5. Solder .001 cap across the 15K resistor, or from pin 2 to ground.
6. Apply power; there should be a very noticeable increase in audio gain.

I did not try different values for the feedback resistors. If you roll your own, make the resistor from pin 2 to ground to be .015 times the feedback resistor ... or, the same ratio as above.

The cap from pin 2 to ground prevents audio oscillation and can be .001 to .1 range. Frankly, my sloppy breadboard of the above didn't need the cap, but it should be added as a precaution anyway.

WITHOUT adding the 200 gain positive feedback mod, here's what I got on the LM380, wired similar to the 40-9er:

GAIN PROFILE with a 9V battery Where  $V_{in}$ =input sine wave

p-p  $V_{out}$ =LM380 output

p-p with 8-ohm speaker as load

$A_v$ =voltage gain

Gain(dB)= $20\log A_v$

$V_{in}$	$V_{out}$	$A_v$	Gain (dB)
10mv	400mv	40	32
20	850	42	32
30	1500mv	50	34
40	1800	45	33
50mv	2200mv	44	33
60	2100	35	31 Gain compression starts
70	2000	29	29
80	2000	25	28
100mv	2000	20	26

#### FREQUENCY RESPONSE

Frequency response measured with test

$V_{in}=22\text{mV(p-p)}$  in for  $V_{out}=1000\text{mV}$  at 1 KHz for reference.

**Freq. Av Gain(dB)**

10Hz 31.8 30dB  
20Hz 38.6 32  
100Hz 45.5 33  
300Hz 45.5 33  
500Hz 45.5 33

Test signal applied to -INPUT,+INPUT grounded (40-9er configuration)

1KHz 45.5 33  
3KHz 54.5 35  
5KHz 52.0 34  
10KHz 50.0 34  
20KHz 50.0 34  
100KHz 50.0 34dB

Pretty darn flat from 20Hz to 100KHz DC Current draw on the LM380 (14-pin version) at 9v was 8.5mA. Note that with a 9v battery, the stated VOLTAGE gain of 50 is actually quite close. I was at first afraid that was acheivable only at +12v.

**SUMMARY:** On both headphones and speaker, kicking in the feedback circuit makes the audio sound 2-3 times louder. I could hear audio in the earphones with  $V_{in}$  down to 4mV. If it were CW, I could have copied it. It is a 3 component modification, which can be added on the circuit side of the board, takes no extra board space, and pretty easy to do.

Try it, have fun, work somebody with it, and let us know how it went. I think we QRPers are the first human beings to actually employ the positive feedback design from the LM380 application notes AN-69.

72, Paul NA5N

Return to [Table of Contents](#)

---

## 40-9er history and Comments

by Wayne Burdick, N6KR

[svecbrdk@well.com](mailto:svecbrdk@well.com)

Hi folks, the history of the 40-9er is approximately this:

Early 1995: I saw/heard some of the Pixie transceivers that people had built last year, and thought

much better performance would be possible with just a few more parts.

Late 1995: Doug found some 7.040 crystals at the swap meet. He needed a rig designed to help use them up.

These events left me no choice but to do the 40-9er. Since there were so few parts (about 1/4 as many as a NorCal 40A, for example), I figured it was a good opportunity to design the rig around a 9V supply voltage. Then you could put it into a very small box. Doug did a nice PCB layout to achieve this.

Some things to keep in mind if you build one:

- \* The limited VXO range has to do with how far you can pull an NE602 oscillator without having it stop. I used an RF choke, but you can increase the pull with a large toroid (like 60 turns or more on a T68-2 or T68-6). But be careful at the low end of your VXO trimmer cap: if the capacitance nears zero, it may stop oscillating (especially when you transmit, which loads the crystal further).

- \* That 1/2-watt output will drain a regular 9V battery pretty fast, so consider using an alkaline or better yet a lithium battery (available from Mouser). A lithium battery costs twice as much as an alkaline, but you'll get something like 60 hours of operation!

- \* To keep parts count low, I used an LM380, and only a single-ended connection between that and the product detector (an NE602). You could increase the audio output quite a bit by adding a second JFET and going to differential coupling between the 602 and 386. As it stands there is enough audio to drive headphones to a reasonable volume in a quiet space.

- \* I'm running everything except the final amplifier off of 5V so that receiver performance and frequency stability will be good down to 6.5V or so. To save a few more milliamps and allow the rig to run all the way to 5.1V, you could substitute an LP2950-5.0 low-dropout regulator for the 78L05.

I worked Michigan (2000 miles) on mine. Have fun!

73, Wayne N6KR

Return to [Table of Contents](#)

---

## **Sub the LM386 for the LM380 in the 49er**

**by Wayne Burdick, N6KR**

[svecbrdk@well.com](mailto:svecbrdk@well.com)

The 40-9er uses an LM380N-8 to minimize parts count, but if you can't find one, you can easily modify



the PC board to use an LM386 instead.

1. Cut all of the traces running to pins 5, 6, and 7. You can use an exact-o knife for this.
2. Reconnect the trace(s) that went to pin 7 to pin 6. Use a very short piece of bare copper wire.
3. Similarly, reconnect the trace(s) that went to pin 6 to pin 5.
4. Obtain a 100 to 180 ohm resistor and a 2 to 10uF capacitor.
5. Connect the (-) lead of the capacitor to one lead of the resistor (keep this and other leads short). Connect the (+) lead of the capacitor to the pin 1 pad of the IC. Connect the free end of the resistor to pin 8.

That's it. The reason step 5 is necessary is that the 386 has only 26dB gain with no external components, while the 380 has 34dB gain (fixed). By adding the R and C in series between pins 1 and 8, you'll make up the difference. In fact, you can make the R smaller or larger to change the gain as needed. Making R a short will result in a gain of 46dB, which would be too much for the 40-9er board and cause instability.

Also keep in mind that you can convert the single-ended connection from the '602 to the '386 into a balanced configuration to improve gain and stability, and possibly improve the muting characteristics. If you want to do this, look at the NorCal 40 schematic. The main difference is that the NorCal 40 doesn't use the 82mH inductor. You should use two of the inductors, one in each leg, to retain the low-pass filtering feature of the 40-9er.

Looking at the 40-9er schematic, it occurs to me that a bypass cap might be helpful from pin 8 to ground on the LM380 (or pin 7 to ground if you're using an LM386 instead). The cap can be anything from 2 to 100uF. Negative end goes to ground, naturally. The audio output isn't high enough to make the bypass cap a necessity, but you may want to try it if you think the audio is distorted on loud signals.

Also, I forgot to mention that the LM386 has one limitation: the supply voltage should be 12V or less for the standard LM386N-1. You can of course use the LM386N-4 instead, which allows for up to 22V. But voltages above 12V are not recommended for the 40-9er anyway unless you heatsink the final amp adequately.

72, Wayne, N6KR

Return to [Table of Contents](#)

---

## Putting the 49er in an Altoids Case

by Stan Wilson, AK0B

Yes it can be done. Use a RS type RCA phone plug for the antenna, Use the RS 2.5 mm jacks for audio

and key. Close the case and layout the holes. Then remove the lid for drilling. When you close the lid it will just touch the jack hardware whisker close.

Use 1/32 plastic sheet (I cut mine to the same size as the PC board) for an insulator under the assembled board. I installed the jacks on the ends. RF on left and other two on right. I installed a 0.1 molex terminal for the battery on the pc board. The jacks will have to go toward the rear of the box.

Space the two (audio and key) jacks about 3/8" apart. I did 1/4 and that is too close for most RS type 2.5 plgs. You will have about 1/32 spacing above the componets on the PC board when closed.

Back up the thin case when you drill it out. The thin metal can tear if you do not. I played with it about a week before I drill any holes.

72 de Stan AK0B

Return to [Table of Contents](#)

---

## **My Mods to the 49er** by Larry East, W1HUE/7

I increased the size of the bypass caps in the emitter circuit of the driver transistor and on the +V side of the decoupling choke to the final transistor from 0.01 to 0.1 uF. At 7 MHz, the impedance of a 0.01 cap is about 2.3 Ohms \_ seems to me that 0.1 uF (0.23 Ohms) is a better choice for a bypass.

I found that changing the choke in the final collector from 15 uH to 22 uH increased the output by 30%. With 15 uH, output is 0.70W; with 22 uH, it is 1.0W. I tried an 18 uH choke and that also gave about 0.7W. These measurements were made with 13.2V on the collector of the 2N4427 final and 6V (rather than 5V) to the NE602.

I found the source of the low audio \_ a bad solder connection! I'm using small two-pin "strip sockets" for the antenna, etc. connections on the board, and the one for the speaker (? get serious; this thing won't drive a speaker!) output had a bad ground connection \_ it finally opened entirely, which is how I found it! Much better now, but still not ear-splitting.

I changed the order of the choke and trimmer cap in the VXO so that the side of the trimmer connected to the "tweak screw" is grounded. Much better \_ a metal tipped alignment tool can now be used to change the VXO frequency without screwing up the oscillator. This seemed like an obvious oversight in the original design, and according to a recent post from Wayne it was.

An interesting side effect: after this change, the VXO range decreased from 5.1 kHz to 4.8 kHz. The same choke and trimmer cap (and crystal, of course) were used in both cases \_ change in stray circuit capacity perhaps?

The simple mod involving feedback around the LM380 suggested by Paul, NA5N, sounds like it might be worth while \_ I'll check it out. I have the applications handbook he mentioned at home, so I'll look it up. By the way \_ the potential problem mentioned by Paul concerning no load on the audio amp output can be circumvented by connecting a 150 to 270 Ohm resistor from the audio output decoupling cap to ground (i.e., across the phone jack). This also eliminates the loud "pop" that occurs (with the unmodified circuit) when headphones are connected after power is applied to the rig (due to the output cap discharging thru the headphones). I routinely do this on all my rigs.

I am a firm believer in the "KISS Principle" (Keep It Simple, Stupid!), so it is not my intent to turn this little rig into a "Monster". There are a lot of additions one could make, like a series resonant circuit at the receiver input to reduce shortwave broadcast feed-thru (I'm picking up some religious station at times, don't know what frequency it's on), balanced input to the audio amp, etc., but I don't intend to do all this since this is REALLY a "toy rig" as far as I am concerned and it is interesting to see what CAN be done with a minimum number of parts. Component changes to optimize performance, on the other hand, I just can't resist doing...

72 and happy tinkering \_ Larry W1HUE/7

Return to [Table of Contents](#)

---

## Improved audio filtering for the 40-9er

by Ori Mizrahi, AC6AN

[mizrahi@svlhp8.scs.philips.com](mailto:mizrahi@svlhp8.scs.philips.com)

I followed the LM-380 positive feedback scheme for the 40-9er and it does work. The one thing I wasn't happy with was the poor audio filtering. The setup resulted in a stronger audio, i.e. amplified QRM...

Of course this was never intended to be anything more than an easy-to-build radio, and no complaints - like most anybody else - I love it!

Once I started tweaking the audio amp it dawned on me that we can revert to the LM-386 and with roughly the same circuit complexity achieve better filtering and lower power too.

No major development, just copied from the NC40A, sort of. I don't have the Norcal PCB, so can't advise on that, but it should be easily done on that PCB too. N6KR described most of the basic mod earlier, I added the bypass cap from pin 7 and the RC between pins 1 and 5.

The full LM-386 circuit goes like this:

- \* Pins 2,4 to Ground.
- \* Pin 6 to +Vcc (similar to LM-380 pin 7)

- \* Pin 3 is the input, connected to RFC2/C10 (same as LM-380)
- \* Pin 5 is the output, connected to C13(+), same as LM-380 pin 6

The additional circuitry:

- \* 10 microfarad cap between pin 1 (+ side) and pin 8 (- side)
- \* 0.1 microfarad (or bigger) from pin 7 to Ground
- \* 1800 ohm resistor in series with 0.022 microfarad cap between pins 1 and 5

This is audio circuitry, so somewhat longer wires can be used, although it's always a good idea to keep them short due to the high gain.

The result:

Calculated about -8dB for 3KHz vs. 500 Hz, sounds pretty much as predicted. It's absolutely an improvement, but -8dB are not exactly a "brick wall", especially if your tiny earphones favor the squeaky part of the audio spectrum. So, next we'll try a low-power dual-opamp active filter with some gain to cut some parts from the LM-386 circuit. Now that we saved a few mA at the audio stage, can afford some extra current somewhere else!

73 DE ORI AC6AN

Return to [Table of Contents](#)

---

## Power "Switch" for the 49er

by Ori Mizrahi, AC6AN

[mizrahi@svlhp8.scs.philips.com](mailto:mizrahi@svlhp8.scs.philips.com)

I put the 49er in a box and had to worry about the inconvenience of disconnecting the battery. I talked with a Jeff KD6MNP and he was "surprised" I don't use what he considers a natural power switch.

This is taking advantage of a STEREO 1/8" socket and the fact that a MONO plug shorts the middle contact to the ground (not the tip).

Wire the earphone socket in the following manner:

- \* TIP - audio out (from C13)
- \* MIDDLE - BATTERY (-) SIDE
- \* GROUND - PCB Ground

Jeff also warned to plug in the earphones BEFORE they're in your ears. I'll appreciate if anybody let me know what happens otherwise!!!

73 DE ORI AC6AN

Return to [Table of Contents](#)

---

## Simple Power Supply Instability Fix

by Ori Mizrahi, AC6AN

[mizrahi@svlhp8.scs.philips.com](mailto:mizrahi@svlhp8.scs.philips.com)

One potential \*giant\* source of instability is the battery! You eliminate this problem with a bypass cap across the supply.

I added a 0.1 cap in parallel to C12, probably a good thing to do in general. So far the radio is totally imune to supply noise. I tried NiCad, Alkaline, a regulated linear supply and a laptop switcher, all with the same good results. Mine is built on a proto board with a ground plane, so ground loops are not an issue.

73 DE ORI AC6AN

Return to [Table of Contents](#)

---

## 40-9er Correction: Receiver Input Tuned Circuit

by Wayne Burdick, N6KR,

[svecbrdk@well.com](mailto:svecbrdk@well.com)

If you think your 40-9er's receiver is too weak, it may be that C20 is too small. (I considered changing it from 150 to 180 pF but missed the publication deadline.) Rob Capon sent me the message below, confirming that on some 40-9er's, an extra cap paralleled across C20 may get the tuned circuit into the proper range. Which brings up the following question:

Q: Why does the 40-9er need so much capacitance in that tuned circuit, when the NorCal 40 and some other designs use the trimmer by itself, with a much larger inductor?

A: The reason is that the 40-9er is direct conversion, making it much more likely that hum and A.M. broadcast stations picked up at pin 1 of the NE602 will make it to the AF amp. By using a much larger capacitance here, the Q of the circuit is improved, and the NE602 "hears" less

interference. I haven't quantified the effect, but I noticed that with the usual small amount of capacitance, things get much worse. The tradeoff is that with C2 being a smaller part of the total capacitance, the value of C20 becomes more critical.

Another way to achieve the same thing is to tap down on the inductor on the '602 side—but hey, that requires a toroid and the 40-9er was supposed to be toroid-less.

73, Wayne, N6KR

Return to [Table of Contents](#)

---

## **Case for the 49er**

**by Robert Capon,**  
[RobCap@aol.com](mailto:RobCap@aol.com)

I have built my 49er, which I'm enjoying very much. Clearly it is not a rig that's going to see lots of air time, but definitely worth having some novelty QSO's.

Radio Shack sells a very nice beige plastic case for \$5.25 that works great. The 49'er board fits neatly into the main compartment (after I notched the two lower corners, that-is), and there is a small compartment designed to house a 9-volt battery. The case comes with a 9-volt battery clip as well.

The box has a removable side panel, which is where I attached four components: antenna jack, key jack, phones jack, and on/off switch. Because the little panel slips out, wiring is a breeze.

So, if you don't mind the total radio cost escalating from \$25 to \$30, you might want to take a look at this case. (By the way, I had looked at a Sucrets case, but the battery would have to be external. Decided the Sucrets case was too spartan.)

73, Rob

Return to [Table of Contents](#)

---

## **The Altoid Oreo 40-9er**

**by Floyd Smithberg, NQ7X**

I call my 49er the Altoid-Oreo 40-9er....Battery wouldn't fit in case so cut about 1/8" off the right end of pcb at and rounded corners on opposite end. Bat now lies flat nicely in case. I used the usual snap connector with loose plastic cover removed and the terminals covered with non-corrosive RTV and

unplug battery and put back in case reversed (disconnected) when not in use. I put piece of plastic tape inside the case to prevent the terminals shorting to case when bat not in use.

Then, in working on mods got tired of having to unsolder and disconnect jacks etc to remove from case so cut out bottom of Altoid box only under pcb, leaving the part under the battery and about 1/4 inch around the other 3 sides. Used hand nibbler, scissors, files etc. Used only one 4-40 to hold the board and single sided tape to space the board from the bottom of the case on the end opposite the battery.

Now, how to cover the bottom? Just take another Altoid box lid and snap it on...voila, an Altoid Oreo. Now you have a typical NorCal rig ....both sides available for service or show and tell!

72, Floyd NQ7X Phoenix ScQRPion Club

Return to [Table of Contents](#)

---

## 40-9er Alignment and Output Power

by Ori Mizrahi, AC6AN,  
[mizrahi@svlhp8.scs.philips.com](mailto:mizrahi@svlhp8.scs.philips.com)

The instructions with the kit tell you to peak C2 for max signal on receive. I found that there is quite a wide range that the reception is satisfactory. I also found that C2 has a major impact on the output stage loading, when R1 is at max resistance (where I suspect most people will leave it). It also tunes very sharply in this regard. The alignment procedure should include output power peaking, not only receive signal peaking. If you wonder why nobody hears you, check this first!!!

When the RF GAIN is set to a max signal, R1 is at max resistance of 1K or 2K, depending on what was supplied with the kit, and can be ignored for this analysis. If the paralel L/C circuit is NOT resonant, it presents a low impedance to ground at any frequency OFF resonance, possibly lower than the 50 ohm at the antenna terminals. The RF then favors this path to ground through C20, C2, RFC1 or C7-D1.

Notice the differences between receive and transmit. On receive, D1 is floating and C7 is terminated at the high impedance input of the NE602, thus it is not a factor in the resonance of that circuit on receive.

On transmit, D1 shorts C7 to ground, making it a part of this circuit. That is the exact detail that needs more attention. Tuning the circuit for max receive signal makes it resonate at the operating frequency with C7 essentially NOT in the circuit. That same circuit is NOT resonant on transmit, when C7 becomes a part of it, and it forms a low impedance path for the transmit signal to go to ground.

Fortunately, the receive peaking is fairly wide range. If you align C2 for max transmit output, the reception is acceptable, but not necessarily the other way around.

The alignment step should be:

\* Connect a 50 ohm dummy load to your antenna terminal through a power meter. An SWR meter in the FORWARD position can do the job too, as it shows the peak relative power.

\* Key the transmitter and change C2 until peak power is observed.

JOB COMPLETE!

73 DE ORI AC6AN

Return to [Table of Contents](#)

---

## Choke Your 40-9er, Now!

by Wayne Burdick, N6KR

[svecbrdk@well.com](mailto:svecbrdk@well.com)

Based on a couple of messages I received I now can say with some confidence that the rev. B 40-9er board, at least, must have the driver and PA RF chokes in too close proximity. This is what's probably causing the reported "Squeal" (oscillation) on transmit.

There are two cures, either of which seems to work. I recommend that everyone make mod 1 or 2, even if you don't know that your unit is oscillating, and even if you have a rev. A board. This may also improve 2nd harmonic attenuation that was discussed earlier on the list.

1. Put a 1K resistor across each choke (the chokes in the collector leads of the driver and final transistors). If 1K doesn't do it, try 470 ohms on the PA choke.

\_ OR \_

2. Replace the PA choke with 8 to 10 turns enamel wire (nearly any size will do) on a high-permeability toroid core, such as an FT37-43 or FT37-50. If necessary, do the same for the driver choke (shouldn't be necessary).

Here's what I think is happening, although I've never seen in person the rev. B board or a unit with oscillation. The two chokes are fairly close together on the PC board, so it's almost like they're two halves of a bad transformer. With enough coupling between the two, bingo you've got an oscillator.

Either the 1K resistor or the toroid will drastically reduce the Q of these chokes, so that they can't "talk" so effectively at the frequency of oscillation.

Neither choke is critical. The idea is to suppress RF while passing DC. The rule of thumb is usually that the choke's inductive reactance should be at least 10 times the intended collector impedance, but it can be



much more than that as long as there are no undesirable resonances or DC voltage drop or inter-winding capacitance. This is why the FT37-43 core is so useful here: it won't resonate at 7MHz no matter what you do, and the permeability is so high that you only need a few turns, hence the low DC resistance of the winding and the low inter-winding capacitance.

42uH (10 turns on an FT37-43) is plenty for both driver and final. I used 1mH at the driver to hopefully make it less likely to have any unwanted self-resonances. But I couldn't use 1mH at the PA because that particular choke has so much internal resistance that it would have a significant DC voltage drop. The idea was to use no toroids, but in hindsight I should have put swamping resistors on the board just to be safe since I wasn't the one laying out the PC board.

73, Wayne, N6KR

Return to [Table of Contents](#)

---

## 40-9er Self Oscillation Fix

by James L. Jendro, K8WVG

[jlj@tiac.net](mailto:jlj@tiac.net)

I now have my Rev. B 40-9er up and running without self-oscillations on xmit at 9v. I don't have a clean way to measure power output at home, will have to wait till I can use a 'scope at work.

Anyway, this is the "cure" for my rig...

- 1) Bypassed the 5v regulator with .01 uf on input and output side as well as a 10uf tantalum the output side. => Self oscillations still there.
- 2) Changed .01 uf V+ bypass on driver and final to .1 uf. => Self oscillations still there.
- 3) Added 1K resistor in parallel with the final's choke. => Bingo! Reducing the Q seems to have done the trick. If I notice any more self-oscillation I'll try the same thing on the driver's choke. Now, for that first QSO...

Thanks to Wayne and Doug for the info/help/design.

73, Les K8WVG

Return to [Table of Contents](#)

---

## 40-9er "Tweaks" and Tips

by Larry East, W1HUE/7,

[LVE1@inel.gov](mailto:LVE1@inel.gov)

1. Change C11 and C19 to 0.1 uF for better RF bypassing (original schematic shows these as 0.01 uF).
2. A 78L06 can be used in place of a 78L05 for a little more "oomph" from the NE602 and still allow operation from a (reasonably fresh) 9V battery.
3. Add a 0.1 to 1.0 uF cap between the output of the 78L05 (or 06) regulator to ground; these critters will sometimes oscillate when their output is not bypassed.
4. If you plan to use an AC power supply, add a 1 to 10 uF cap from pin 8 of the LM380 to ground to reduce power supply hum and noise. (4.7 uF or so should completely eliminate any power supply hum unless the supply is very poorly filtered.)
5. A 2N4427 or a 2N3053 (available from Radio Shack) can be used for Q3 (the final amplifier) in place of a 2N3866. A 2N3553 or 2SC799 will probably give a little more output, however.
6. I found an easy way to keep the oscillator output from dropping off drastically at the high-end of the tuning range: add a 4-6pF cap from the "bottom" of the xtal directly to ground. In other words, shunt the L/C series network that is connected from the xtal to ground with a 4-6pF cap (small ceramic type is OK). This keeps the oscillator output from dropping at the low capacitance end of the tuning cap without significantly reducing the tuning range. It does reduce the high-end of the range by 0.2 - 0.3 kHz, but this is less than the reduction that would occur (about 1kHz) if the same size cap is shunted directly across the tuning trimmer (assumed to have the recommend 9-50pF range) and it seems to have a greater effect on oscillator output. Its only one more part...

Your results may vary, but 5pF worked for me (3pF did not keep the oscillator output from dropping). If the low-end of your tuning cap is less than 8-10pF, then a larger capacitor may be required.

72, Larry W1HUE/7

Return to [Table of Contents](#)

---

## **40-9er success!**

**by Mike Hagale, AC6JA**

[AC6JA@aol.com](mailto:AC6JA@aol.com)

I just finished building the 40-9er and packaging it with the KC-1 keyer. I have made three contacts already, Turlock, Death Valley, and San Jose, Ca. from my qth in Foster City, Ca. The rig seems to put out almost 1 Watt when running off my Radio Shack 2.5 amp regulated power supply at close to 15 volts. It sure takes some getting used to listening to a direct conversion receiver after being used to the Wilderness 40A, Sierra, and new Qrp Plus.

I put the 40-9er and KC-1 in a small metal case with lithium battery, and put two small momentary push button switches on either side of the case to act as my iambic paddle. It sure works out great. Now that everything works, it's time to start modifying the rig. The antenna used is a 40m hamstick dipole mounted on a telescoping painter's pole on the balcony of the townhome at 16ft!

72 Mike

Return to [Table of Contents](#)

---

## **49er Battery Mod**

**by John, N5INZ**

I spoke with Alan, of the Famous SoCal Gang, about a mod for you folks who insist on the Mint Boxes. I got a handfull of 3.6v @ 60 mAh ni-cad batteries that are used for maintaining the BIOS in computers. They are about .75 x .5 inches. 3 in series would give you 10.8v. The bonus is that all three are smaller then a 9v rectangular and re-chargable. 2 sets and you have a change while the other charges.

Another idea would be to build a charger that plugs into the cigarette lighter.

72, John-N5INZ

Return to [Table of Contents](#)

---

## **Solving Two 40-9'er Problems with One Mod!**

**by Alan Kaul, W6RCL**

[kaul@netcom.com](mailto:kaul@netcom.com)

I had one of the original boards and built one of the original designs (C20=150 pf). I had two complaints \_ the rig had a strong SW broadcast station (WEWN, Birmingham, AL) overloading the receiver, AND the receiver input circuit (C20, C2, RFC1) didn't really tune the same frequency that the crystal VXO did. In subsequent posts (here) by W1HUE/7 and N6KR, Larry and Wayne reported the circuit tuned higher in frequency than it should and the easy fix was to replace C20 with a 180 pf cap. Last night I soldered into place an even better fix!

On the theory that the SW station was there because the input circuit was not resonant, I thought I might try eliminating it by replacing RFC1 with a torroid (remember Wayne reported over the weekend that even though the rig was to be "torroid-less" that the best fix for a squeal in the version B board was to replace a couple of chokes in the xmtr stage with FT-37-43 handwound coils). So with the torroid-lamp-clearly-lit by the designer himself, I plunged ahead.

Using the traditional formula for  $X_c = 1 / (2 \times \pi \times \text{freq} \times C)$ , I found that a capacitance of about 180 pf (C20 + approx midrange of C2) would resonate using a coil size of approx 2.8 uH. Then I used the torroid winding formula of  $\text{Turns} = 100 * \text{SQR} (L\{\text{uH}\} / \text{AL value})$ . The charts indicated the AL value of a T-50-2 torroid was 49, and the coil worked out to be about 24 turns. I used #24 wire, threw it together and soldered it in place of RFC1.

WOW, what a difference! In one single step I was able to get rid of the SW crud and to find true 40M resonance in the receiver input circuit. While I was making modifications, I swapped C6 and RFC6, so C6 now connects to ground and RFC6 is isolated between the crystal and the input side of C6. Incidentally, I drilled a new hole for C6 in the large ground plane area (where the silkscreen says '49er by N6KR')!

I thought briefly about making another mod at the same time, using the 2.2 uH choke I removed (soldering RFC1 in series choke with RFC6, the VXO choke) which might increase the swing of the VXO, but I saved it for another day.

One more thing, if you have a parts kit for board B, or have already replaced the capacitor C20 with a 180 pf cap, you can make a 2.2 uH torroid by winding a theoretical 21.189 turns on a T-50-2 (winding 21-turns ought to work!).

The 40-9'er is a terrific little rig. This mod makes it even better!

GL and 73/72 de Alan, W6RCL

Return to [Table of Contents](#)

---

## 49er Measurements by John, WB4OFT

Bob Kellogg AE4IC let me borrow his newly assembled 40-9er and make a few measurements. We thought the rest of the 40-9er owners would like to see the results.

I measured the transmitter performance and got the following results.

Supply voltage = 9volts

- \* Power output = 235mW
- \* Second harmonic = -27.8dB below the fundamental
- \* Supply current = 85mA TX / \*18mA RX

Supply voltage = 12volts

- \* Power output = 480mW
- \* Second harmonic = -24.3dB below the fundamental

\* Supply current = 125mA TX / 20mA RX

NOTE: This rig had some modifications to boost audio gain.

I used an HP8595E spectrum analyzer for the harmonic measurement and a Rhode & Schwarz NRVD power meter for the power measurement.

I was amazed how well such a simple receiver can work. Also, I listened to the transmitter operated into a 50 ohm load and my inverted vee. The 40-9er sounds as good as any commercial rig.

With all the 40-9ers out there, maybe we should have a 40-9er hunt. That would give the rigs a good work out. Hope this information is useful.

72 John, WB4OFT

Return to [Table of Contents](#)

---

## **40-9er harmonics**

**by Alan Kaul, W6RCL**

Using my 40-9er (Board A) I measured 15 dB of second harmonic suppression the first time I tested it, and 16 dB the second time I tried it. Both times, the analysis was performed on a Motorola R-2000 Communications Analyzer. My results varied by some 10 dB with John's post reported today on the list. I hope my measurements were wrong -- because I'd like to think that the rig has better suppression than I was able to find. It is possible the analyzer I used was not working properly, OR that I inaccurately made my measurements OR that the parts I installed were off tolerance (listed values: C17=270pf, RFC5=2.2uH, C18=470pf), etc.

Has anyone else measured the output on their 40-9er's? Theoretically, we should all be getting approximately the same results.

72, Alan W6RCL

Alan,

I looked at the output of my 40-9er (also a Version A board) on an IFR communications analyzer and found about the same thing you did, the harmonic is only about 16 dB down on the fundamental.

72/73, Al Moyle N3KFL

Return to [Table of Contents](#)

## Measuring 49-er Performance

by Alan Kaul, W6RCL

[kaul@netcom.com](mailto:kaul@netcom.com)

One of the perks of working in the broadcast business is occasionally getting into the shop to play with the toys. This morning, I was able to do just that with the 49-er (aka 40-9er) designed by N6KR and offered by the Norcal QRP club.

All of the tests were made using a Motorola Communications System Analyzer -- model series R-2000 (no label on this one, it might have been an R-2001 for example). Performance was measured using various power supply voltage levels, at 7.040 kHz.

### OUTPUT POWER AS A FUNCTION OF INPUT VOLTAGE

#### Voltage (under load) Power output (sum of all emissions)

* 7.0 (AC supply)	0.26
8.26 (used 9v bat)	0.32
8.52 (used 9v bat)	0.33
8.94 (new 9v bat)	0.39
9.0 (AC supply)	0.42
12.0 (AC supply)	0.70
12.5 (AC supply)	0.74
13.4 (AC supply)	0.80

\* -- The test gear is absorptive, the power measured = the sum total of the power on the primary frequency plus the 1st harmonic, plus the 2nd harmonic, etc.

### RELATIVE POWER OUTPUT BASED ON FREQUENCY\*\* (see below) Supply voltage = 12V (AC supply)

#### Frequency (mHz) Power output (W)

7.038	0.65
7.040	0.70
7.0459	0.53

\*\* -- In my rig, the VXO variable capacitor is not the one specified: it has a slightly larger tuning range (8-60pf)

### HARMONIC CONTENT (using 12V power supply, at 7.040 mHz, 0.70 watts)

	F1	F2	F3
Freq	7.040	14.080	21.120
Signal	0 dB	-16 dB	-38 dB

Here is the 2nd day measurements -- same test gear just 24 hours later and with slightly different results.

I went back to the Motorola Communications Analyzer this morning, and put a few more variables into the equation.

First, using a 12-inch clip lead (as opposed to soldering jumpers and unsoldering parts) I measured harmonics at the input to the pi-output filter.

Obviously my method was NOT perfect, I'm sure I introduced stray capacitance and stray inductance. But it's what I had in the time that was available.

**Measurements with no harmonic attenuating filter.**

<b>Power Supply</b>	<b>Power Output</b>	<b>F1</b>	<b>F2</b>	<b>F3</b>	<b>F4</b>
		(dB)	(dB)	(dB)	(dB)
Voltage (Watts)*					
9.0	0.47	0	-5	-13	-25
13.0	0.64	0	-5	-15	-25

\* -- POWER OUTPUT is the sum of all emissions (i.e F1+F2+F3+...etc)

**The output of the rig was then measured at the coax connector:**

<b>V</b>	<b>Power</b>	<b>F1</b>	<b>F2</b>	<b>F3</b>	<b>F4</b>
7.0	0.25	0	-17	-37	-39
8.0	0.34	0	-16	-37	-38
9.0	0.42	0	-16	-37	-38
10.0	0.52	0	-15	-36	-38
11.0	0.60	0	-14	-36	-37
12.0	0.67	0	-15	-37	-38
13.0	0.75	0	-15	-37	-38

NOTE: Some of today's measures might differ slightly from measurements made with the same equipment with the same power source, with the same transmitter, etc., yesterday(!)

All measurements were made at a nominal frequency of 7.040 (I didn't calibrate for each measurement, and only occasionally looked at the freq. counter, but the VXO was not changed between tests, and on those few occasions when I looked at the freq counter, it was more than 200-250 cycles off frequency).

NOTE: The key-down for 13.4V was approximately 2-minutes. I did not have a heat sink installed on the 2N3866 and it ran quite hot. I'd recommended not running it at that power level without a heat sink. I make no claims for the output of any 49-er other than my own -- yours may or may not perform similarly.

The 49-er is a great little rig. Wayne has done a terrific job -- he's been able to get a lot of out of a tiny Altoids' box!

72, Alan Kaul, W6RCL kaul@netcom.com

Return to [Table of Contents](#)

---

## 40-9er Power Drop W/1K Resistors

by Wayne Burdick

[svecbrdk@well.com](mailto:svecbrdk@well.com)

Paul, WB8ZJL wrote:

I finished the 49er and it had the (typical) intermittent self -oscillation problem. The problem went away when I added the 1K ohm resistors across the RF chokes but the RF power dropped about in half.

Looks like 100mw output (+/- 100mw)

Is this "normal?" Would toroids fix it? Any way to get a sidetone out of the thing? Boy it's COOL... thanks again Wayne and NorCal!!!

73 =paul= wb8zjl

Paul, try resistors > 1K across the driver choke to find one that kills the oscillation but not the power.

For a better solution than resistors, use FT37-43 toroid cores for both the driver and final chokes. Anything from 8 to 12 turns on each ought to don it--it isn't real critical. The rule of thumb is that the inductive reactance of the choke should be 10 times the collector impedance of the stage. By this logic, the driver choke should have more turns, but my guess is that it won't make much difference. Experiment!

I finally received a rev. B 40-9er board myself, and Doug Hendricks did an excellent job. He and I both learned a few things about placement of RF chokes, though! The close proximity of the driver and final chokes may be the cause of the oscillation, and would explain why switching to toroids would cure it.

One thing I haven't looked at is whether you could keep the chokes as they are, but simply relocate them as far apart as possible on the PC board. In other words, tack solder them on--don't use the existing holes. Anyone try this?

73, Wayne N6KR