

Radio Receivers, *from detector to stereophonic device*

Author: Miomir Filipovic, B.Sc.EE

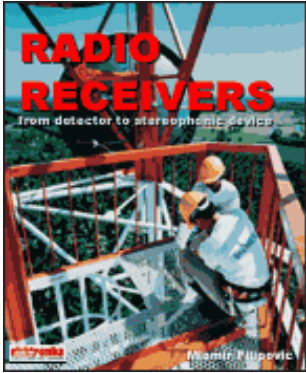

INTRODUCTION

Chapter II PRINCIPLES OF RADIO TRANSMISSION

- [2.1. AM Transmitter](#)
- [2.2. FM Transmitter](#)
- [2.3. Wavebands](#)

Chapter III DIRECT (TRF) RADIO RECEIVERS

- [3.1. The Simplest Radio Receiver](#)
[chapter3\chapter3a.htm](#)
- [3.1.2. The Antenna](#)
- [3.1.3. The Ground](#)
- [3.1.4. Other Components](#)
- [3.2. The Simplest Amplified Radio Receiver](#)
- [3.3. Simple Radio Receiver with TDA7050 IC](#)
- [3.4. Simple Radio Receiver with LM386 IC](#)
- [3.5. Radio Receiver with Increased Sensitivity Audio Amplifier](#)
- [3.6. Universal Audio Amplifier](#)
- [3.7. Receiver with HF Amplifier](#)
- [3.8. The Audion - Direct Receiver with Drain Detector](#)
- [3.9.1. Reaction - Type Receiver](#)
- [3.9.2. Direct SW Receiver for AM, AM-SSB & CW Signals](#)
- [3.10. Miniature Receiver with ZN414 \(ZN414Z\) IC](#)
- [3.11. Pocket Receiver with ZN414 & LM386 IC's](#)
- [3.12. Miniature Receiver with ZN415E IC](#)
- [3.13. Receiver with ZN415 & LM386 IC's](#)
- [3.14. Mini Receiver with ZN415 & TDA7052 IC's](#)
- [3.15. Direct \(TRF\) FM Receivers](#)
- [3.15.1. The Simplest FM Receiver](#)
- [3.15.2. The Simplest FM Receiver with Audio Amplifier](#)
- [3.15.3. FM Receiver with One Transistor and Audio Amplifier](#)

[3.15.4. FM Receiver with \(just\) One Transistor](#)

Chapter IV SUPERHETERODYNE RADIO RECEIVERS

[4.1. Superheterodyne AM Receivers](#)

[4.1.1. The Simplest AM Superheterodyne Receiver \(worldwide\)](#)

[4.1.2. The Fully \(not exactly 100%\) superheterodyne AM Receiver No.1](#)

[4.1.3. The Fully \(not exactly 100%\) superheterodyne AM Receiver No.2](#)

[4.2. Superheterodyne FM Receivers](#)

[4.2.1. FM Receiver with TDA7000](#)

[4.2.2. FM Receivers with TDA7088T](#)

[4.2.2.1. Miniature FM Receiver](#)

[4.2.2.2. Stereophonic Receiver](#)

Chapter V APPENDIX

[5.1. Making PCB's](#)

[5.2. Computer - Aided Radio Receiver Control](#)

[5.3. Receivers with NE612 IC](#)

[5.3.1. Synchrodyne AM Receiver](#)

[5.3.2. AM Receiver with Synchro - Detector](#)

[5.3.3. Input Circuits for the Receivers with NE612](#)

[5.4. Universal Audio Receiver](#)

[5.5. Additional Circuits](#)

[5.5.1. Fine Tuning](#)

[5.5.2. Electronic Tuning](#)

[5.5.3. Signal Suppressing of Local Radio Transmitter\(s\)](#)

[5.5.4. Dual Tuning](#)

[5.5.5. Separation of Stages - Preventing the Oscillation](#)

[5.6. The Boxes](#)

[5.7. Bimboard, Protoboard](#)

[5.8. Universal PCB Plates](#)

[5.9. A Modern Oldtimer](#)

Subject :

Name :

State :

E-mail :

Your message:

CHAPTER 1 Introduction

It is hard to imagine what the modern world would look like without the constant exchange of a huge quantity of information. It is currently disseminated by various means such as newspapers, telephone and the Internet. However the fastest way, and sometimes the only way, is by radio. This is where the transfer is by electromagnetic waves, travelling at the speed of light. In radio communication, a radio transmitter comprises one side of the link and a radio receiver on the other. No conductor of any kind is needed between them, and that's how the expression **Wireless Link** came into being. In the early days of radio engineering the terms **Wireless Telegraph** and **Wireless Telephone** were also used, but were quickly replaced with **Radio Communication**, or just **Radio**.

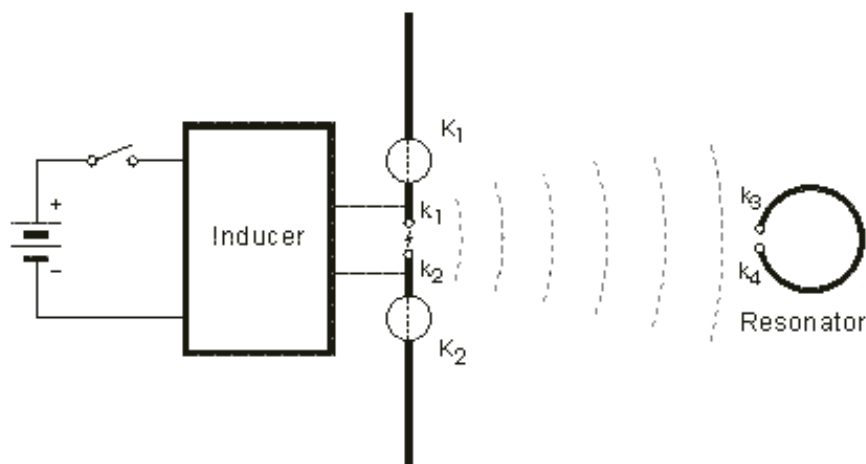

Pic. 1.1. Electrical diagram of Hertz's transmitter / receiver

Radio communication is created by means of electromagnetic waves, of which the existence and features were theoretically described and predicted by James Maxwell, in 1864.

First experimental proof of this theory was given by Heinrich Hertz in 1888, ten years after Maxwell's death.

It was already known at that time that electric current exists in oscillatory circuits made of a capacitor of capacity **C** and coil of inductance **L**. It was Thomson, back in 1853 that determined the frequency of this arrangement to be:

$$f_r = \frac{1}{2\pi\sqrt{LC}}$$

Hertz used an oscillatory circuit with a capacitor made of two bowls, K1 and K2 (Pic. 1.1), and the "coil" was made of two straight conductors. The bowls could be moved along the conductors. In this way the capacitance of the circuit could be altered, and also its resonance frequency. With every interruption from the battery, a high voltage was produced at the output of the inducer, creating a spark between the narrow placed balls k1 and k2. According to Maxwell's theory, as long as there was a spark, i.e. alternating current in the circuitry, there was an electromagnetic field surrounding the conductors, spreading itself through the surrounding space. A few metres away from this device Hertz placed a bent conductor with metal balls k3, k4 placed on the ends, positioned very close to each other.

This also was an oscillatory circuit, called the resonator.

According to Maxwell's theory, voltage induced by the electromagnetic waves should be created in the resonator. Voltage existence would be shown by a spark between the balls k3 and k4.

And that's the way it was: Whenever there was a spark in the oscillator between the balls k1 and k2, a spark would also be produced by the resonator, between balls k3 and k4.

With various forms of the arrangement in Pic. 1.1, Hertz proved that electromagnetic waves behave as light since they could also be reflected and refracted.

It was also shown that light is of electromagnetic nature, as stated by Maxwell.

Hertz, however, did not believe in the practical value of his electromagnetic waves experiments. The range of the link was no further than a few metres. The transmitted signal was very weak, therefore the signal in the receiver had a very small amplitude and it wasn't possible to detect it at a greater distance. The possibility of amplifying the signal in the receiver did not exist at the time.

Besides the short range, another shortcoming of the link was noted: If another similar transmitter was working nearby, a receiver detected all the signals at the same time. It did not have the ability of isolation.

However crude and simple these experiments were at the time, they represented the birth of a new scientific branch - **Radio Engineering**.

The pioneers of radio were Popov and Marconi, but the place of honor belongs to Nikola Tesla, who demonstrated wireless broadcasting in 1893, at the Franklin Institute.

Pic. 1.2 shows the arrangement of this broadcast system.

Tesla's idea was to produce electromagnetic waves by means of oscillatory circuits and transmit them over an antenna. A receiver would then receive the waves with another antenna and oscillatory circuit being in resonance with the oscillatory circuit of the transmitter.

This represented the groundwork of today's radio communications. In 1904 John Flemming created the diode, and in 1907 Lee De Forest invented the triode. That year can be considered the birth of electronics, with the triode being the first electronic component used in a circuit for signal amplification.

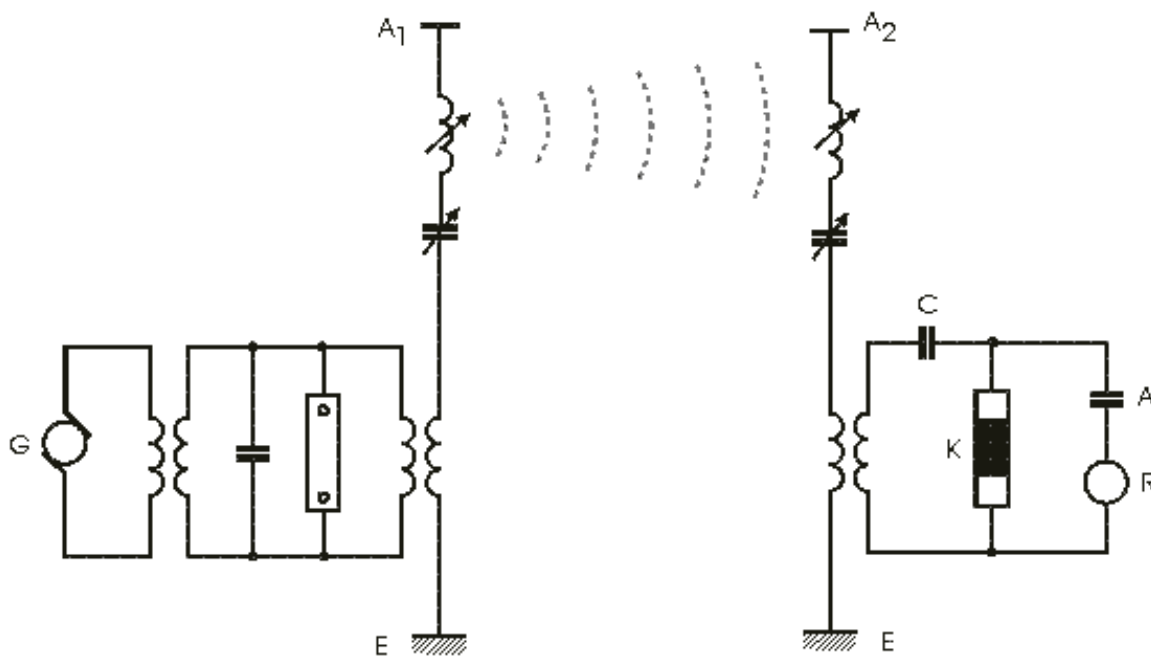

Pic. 1.2. Electrical diagram of Tesla's radio transmitter & receiver from 1893.

Rapid development of radio engineering over the ensuing years produced many innovations and after the First World War a huge number of radio stations emerged.

At that time TRF (Tuned Radio Frequency) receivers were used. Compared to modern receivers they had both poor selectivity and sensitivity, but back then they fulfilled the demands. The number of radio stations was much less than today and their transmitting power was much smaller. The majority of listeners were satisfied with the reception of only local stations. However as the number of stations increased, as well as their transmitting power, the problem of selecting one station out of the jumble of stations, was becoming increasingly more difficult.

It was partially solved with an increase in the number of oscillatory circuits in the receiver and the introduction of positive feedback, but the true solution was the invention of the **superheterodyne receiver**. This was accomplished by Lewy (1917), and improved by E.H. Armstrong (1918).

An enormous impact on the world of radio was the invention of the transistor by Bardeen, Bretten & Schockley, in 1948. This reduced the size of the radio receiver and made truly portable sets a reality.

This was followed by the introduction of the integrated circuit, enabling the construction of devices that not only proved

better in every way than those using valves, but also new designs.

Radio amateurs' contribution to radio engineering should also be emphasized.

In the beginning, radio communication was being conducted in the LW and MW bands. But achieving long-distance reception required very powerful transmitters. The SW band was considered to be useless for radio broadcast on long distances and was given to radio amateurs.

The were banned from using LW and MW bands by commercial radio stations.

However, something unexpected happened: Amateurs were able to accomplish extremely long distance transmissions (thousands of kilometres), by using very low-power transmitters. This was later explained by the influence of the ionosphere layer, the existence of which was also predicted by Tesla.

Modern radio receivers differ greatly from the "classical" types, however the working principles are the same.

The only significant difference is in the way the receiver is tuned to a station. Classical devices used a variable capacitor, coil or varicap diode, with the frequency read from a scale with movable pointer. In modern devices, the adjustment is done with a frequency synthesizer controlled by a microprocessor and the reading is displayed on an optical readout.

The inclusion of a microprocessor enables any one of a large number of pre-tuned stations to be selected and displayed and the use of a remote control makes the receiver even more user friendly.

Chapter II PRINCIPLES OF RADIO TRANSMISSION

[2.1. AM Transmitter](#)

[2.2. FM Transmitter](#)

[2.3. Wavebands](#)

Transfer of information (speech, music, image, computer data etc.) by radio can be presented in its simplest form with block - diagram as on Pic.2.1. That is a transmission realized by amplitude - modulated signal. Since, in our example, the information being transferred is the sound, the first step of such transmission is converting the sound into electrical signal, this being accomplished by a microphone. The low - frequency (LF) voltage at microphone output (Pic.2.1-a), that represents the electrical "image" of the sound being transferred, is being taken into the transmitter. There, under the effect of LF signal, the procedure called amplitude modulation is being carried out, and on its output high - frequency (HF) voltage is generated, its amplitude changing according to the current LF signal value. HF voltage creates HF current in the antenna, thus generating electromagnetic field around it. This field spreads through the ambient space, being symbolically shown on Pic.2.1 with dashed circles. Traveling at the speed of light ($c=300\,000\text{ km/s}$), the electromagnetic field gets to the reception place, inducing the voltage in the reception antenna, as shown on Pic.2.1-c. This voltage has the same profile as the one on Pic.2.1-b, except it has much smaller amplitude. In the receiver, the amplification and detection are carried out first, resulting with the LF voltage on its output, that has the same profile as the one on Pic.2.1-a. This voltage is then transformed into sound by loudspeaker, that sound being exactly the same as the sound that acted upon the microphone. This, naturally, is the way it would be in ideal case. Back to reality, due to device imperfection as well as the influence of various disturbances, the sound being generated by the loudspeaker differs from the one that acts upon the microphone membrane. The block - diagram on Pic.2.1 (excluding the HF signal shape) is also applicable in case of radio transmission being carried out by frequency modulation. In that case frequency modulation is being carried out in the transmitter, under the effect of LF signal coming from the microphone, therefore HF signals on Pics.2.1-b and 2.1-c having constant amplitude, and their frequency being changed in accordance with the actual value of LF signal from the microphone. In fact, all types of radio transmission can be presented with Pic.2.1. First, the information being sent is always transformed into electrical signal through the appropriate converter. In telegraphy this converter is the pushbutton, in radiophony it's a microphone, in television engineering an image analysis cathode ray tube (CRT) etc. Then, with this "electrical image" of information, the modulation is being done. The modulated HF signal is being transferred into antenna and transmitted. On the reception place, the modulated signal from the reception antenna is being amplified and detected and then, again with the appropriate converter (pen recorder, loudspeaker, TV CRT etc.), the information is transformed back into its original form.

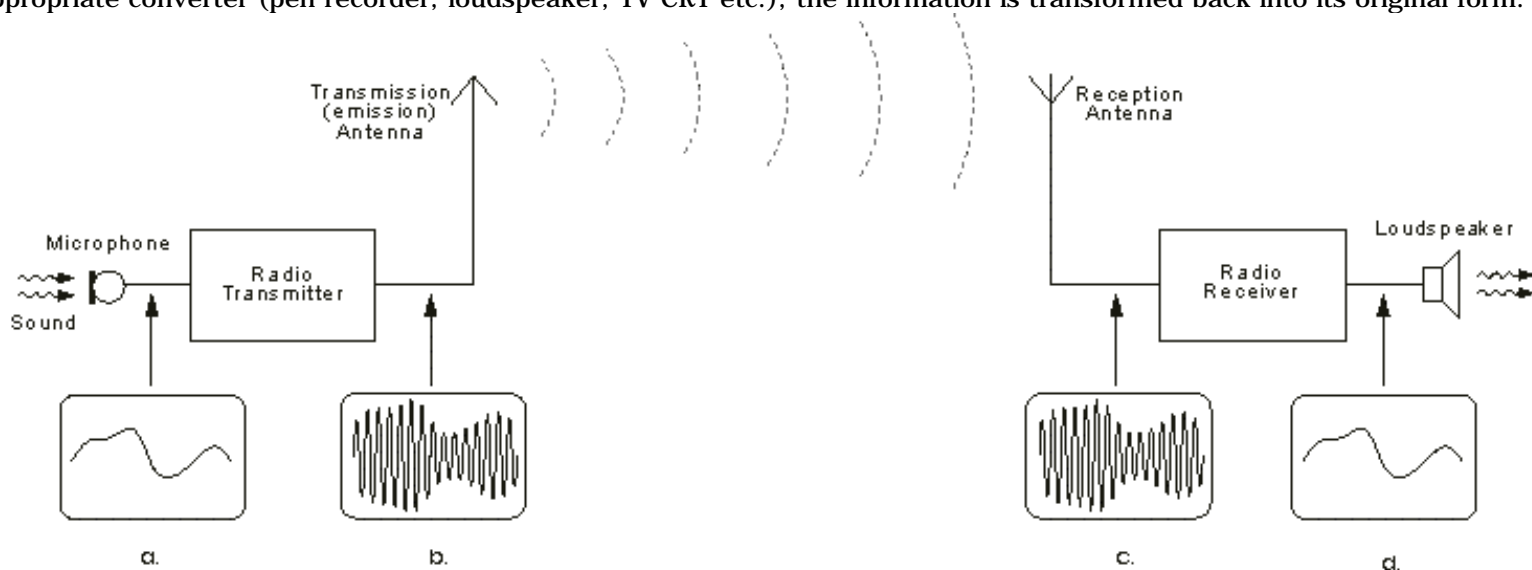

Pic.2.1. Radio Transmission Block-Diagram

2.1 AM Transmitter

In order to better understand the way the radio transmitter works, block - diagram of a simple AM (amplitude modulated) signal transmitter is shown on Pic.2.2. The amplitude modulation is being performed in a stage called the modulator. Two signals are entering it: high frequency signal called the carrier (or the signal carrier), being created into the HF oscillator and amplified in the HF amplifier to the required signal level, and the low frequency (modulating) signal coming from the microphone or some other LF signal source (cassette player, record player, CD player etc.), being amplified in the LF amplifier. On modulator's output the amplitude modulated signal UAM is acquired. This signal is then amplified in the power amplifier, and then led to the emission antenna.

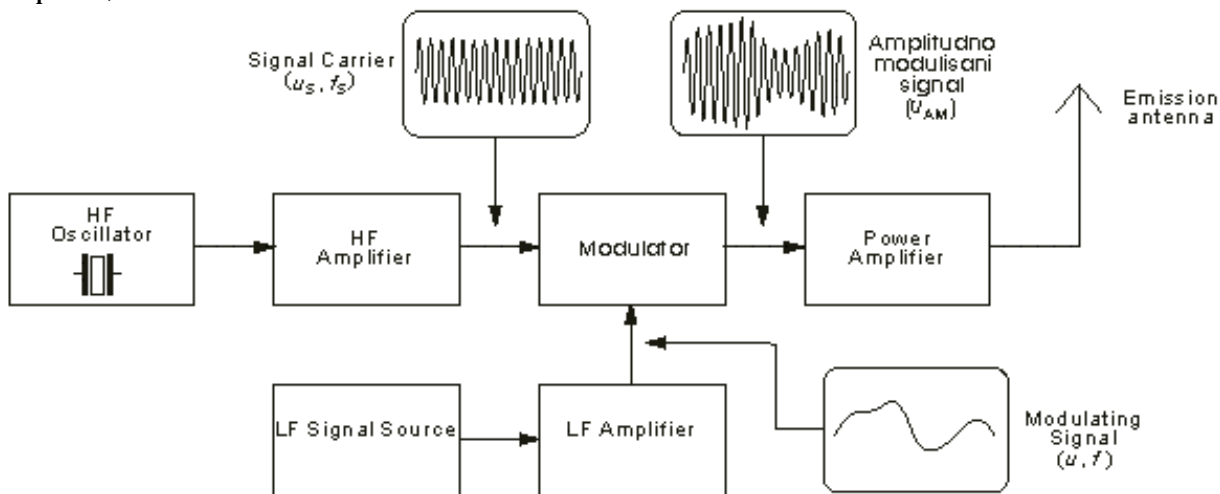
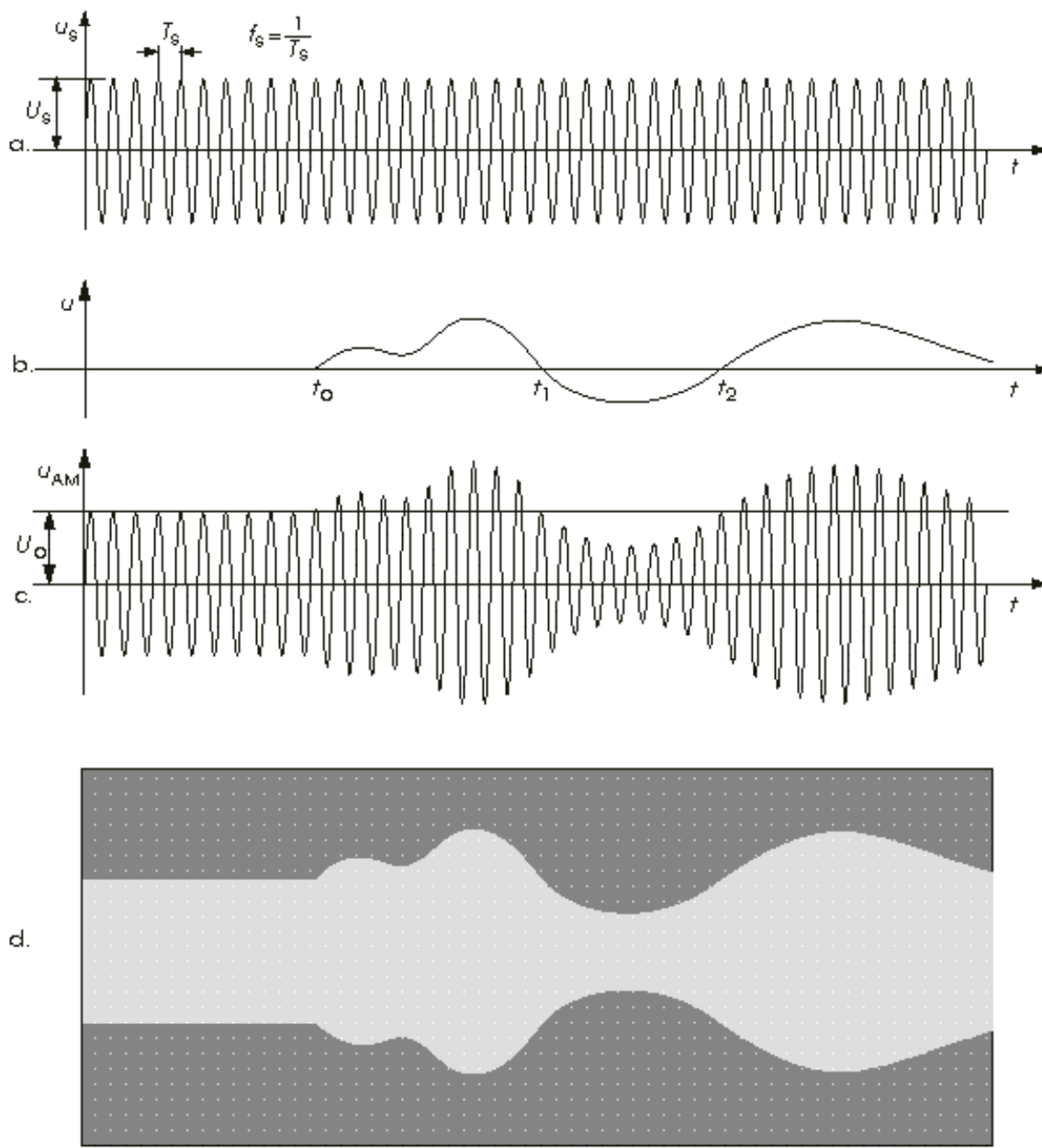

Fig. 2.2. AM Transmitter Block Diagram

The shape and characteristics of the AM carrier, being taken from the HF amplifier into the modulator, are shown on Pic.2.3-a. As you can see, it is a HF voltage of constant amplitude U_S and frequency f_S . On Pic.2.3-b the LF signal that appears at the input of the modulator at the moment t_0 is shown. With this signal the modulation of the carrier's amplitude is being performed, therefore it is being called the modulating signal. The shape of the AM signal exiting the modulator is shown on Pic.2.3-c. From the point t_0 this voltage has the same shape as that on Pic.2.3-a. From the moment t_0 the amplitude of AM signal is being changed in accordance with the current value of the modulating signal, in such a way that the signal envelope (fictive line connecting the voltage peaks) has the same shape as the modulating signal.

Let's take a look at a practical example. Let the LF signal on Pic.2.3-b be, say, an electrical image of the tone being created by some musical instrument, and that the time gap between the points t_0 and t_2 is 1 ms. Suppose that carrier frequency is $f_S = 1$ MHz (approximately the frequency of radio Kladovo, exact value is 999 kHz). In that case, in period from t_0 till t_2 signals u_s on Pic.2.3-1 and u_{AM} on 2.3-c should make a thousand oscillations and not just eighteen, as shown in the picture. Then it is clear that it isn't possible to draw a realistic picture, since all the lines would connect into a dark spot. The true picture of AM signal from this example is given on Pic.2.3-d. That is the picture that appears on screen of the oscilloscope, connected on the output of the modulator: light coloured lines representing the AM signal have interconnected, since they are thicker than the gap between them.

Block - diagram on Pic 2.2 is a simplified schematic of an AM transmitter. In reality there are some additional stages in professional transmitters that provide the necessary work stability, transmitter power supply, cooling for certain stages etc. For simple use, however, even simpler block diagrams exist, making the completion of an ordinary AM transmitter possible with just a few electronic components.



Pic.2.3. Voltage wave envelopes of an AM signal: a- The (signal) Carrier, b- The Modulating Signal (LF signal being transferred), c- AM (amplitude - modulated) signal, d- true look of the AM signal.

2.2. FM Transmitter

Block diagram of an FM (frequency modulated) transmitter is given on Pic.2.4. Information being transferred, i.e. the modulating signal, is a signal from some LF source. It is being amplified in LF amplifier and then led into the HF oscillator, where the carrier signal is being created. The carrier is a HF voltage of constant amplitude, whose frequency is, in the absence of modulating signal, equal to the transmitter's carrier frequency f_s . In the oscillatory circuit of the HF oscillator a varicap (capacitive) diode is located. It is a diode whose capacitance depends upon the voltage between its ends, so when being exposed to LF voltage, its capacitance is changing in accordance with this voltage. Due to that frequency of the oscillator is also changing, i.e. the frequency modulation is being obtained. The FM signal from the HF oscillator is being proceeded to the power amplifier that provides the necessary output power of the transmission signal.

Voltage shapes in FM transmitter are given on Pic.2.5. Pic.2.5-a shows the LF modulating signal. The frequency modulation begins at moment t_0 and the transmission frequency begins to change, as shown on Pic.2.5-b: Whilst current value of the LF signal is raising so is the transmitter frequency, and when it is falling the frequency is also falling. As seen on Pic.2.5-c, the information (LF signal) is being implied in frequency change of the carrier.

The carrier frequencies of the radio diffusion FM transmitters (that emit the program for "broad audience") are placed in

the waveband from 88 MHz til 108 MHz, the maximum frequency shift of the transmitter (during the modulation) being ± 75 kHz. Because of that the FM signal should be drawn much "thicker", but it would result in a black-square-shaped picture.

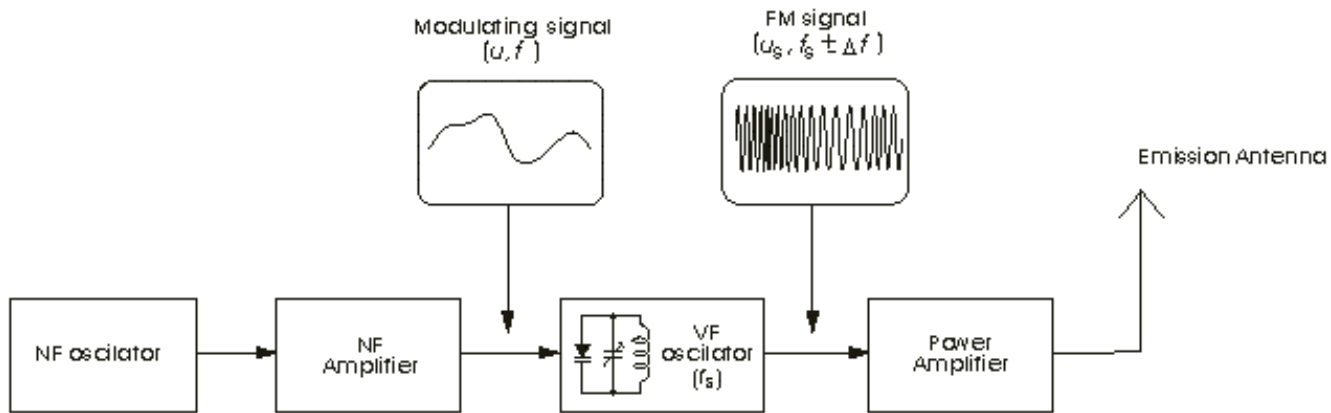

Picture 2.4. FM transmitter Block diagram

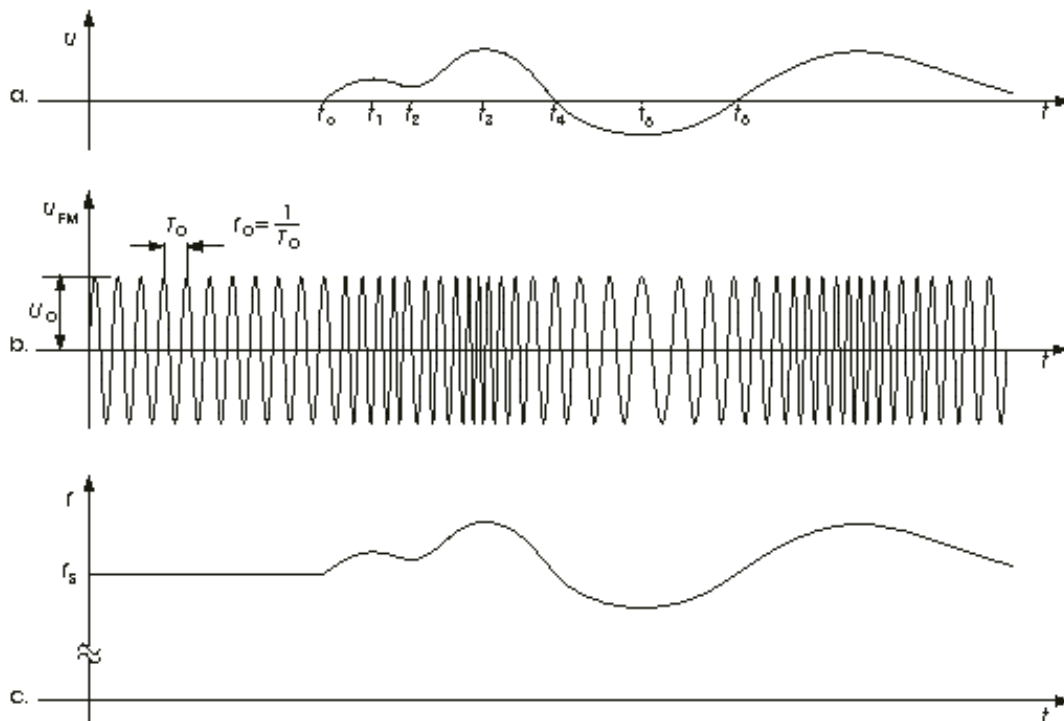

2.3. Wavebands

While considering problems related to the realization of the long - distance radio links, significant differences between the electromagnetic waves of various frequencies must be kept in mind. For example, low frequency waves (below 500 kHz) can bend themselves following Earth's curvature, while the HF waves are moving in streamlines, just as light. Some waves can be reverberated from the ionosphere, others are passing through it etc. According to characteristics of their outspread, radio waves can be classified into several groups or ranges: long, mid, short and ultra-short. Limits between the wavebands are not precise, with the raise of their frequency the waves are gradually losing some features while gaining some others. This division is shown in Table 1.

Table No.1

Range	Frequency	Wavelength
Long waves (LF)	30 - 300 kHz	10 km - 1 km
Mid waves (MF)	300 - 3000 kHz	100 m - 100 m
Short waves (HF)	3 - 30 MHz	100 m - 10 m
Ultra short waves:		
a. Metre range (VHF)	30 - 300 MHz	10 m - 1 m
b. Decimetre range (UHF)	300 - 3000MHz	100 cm - 1 cm
c. Centimetre range (SHF)	3 - 30 GHz	10 cm - 1 cm
d. Millimetre range (EHF)	30 - 300 GHz	10 mm - 1 mm

* LF low frequencies, MF mid frequencies, HF high frequencies, VHF very high frequencies, UHF ultra high frequencies, SHF super high frequencies, EHF extra high frequencies. Waves with wavelength smaller than 30 cm are also called the microwaves.

In the third table column the wavelengths are given. Wavelength (λ) is distance that the wave passes moving at the speed of light ($c=3 \cdot 10^8$ m/s), during the period that is equal to its oscillating period (T): $\lambda=c \cdot T$. Having in mind that the wave frequency is $f=1/T$, one can easily get to the well known expression that gives the relation between the wavelength and the frequency:

$$\lambda = \frac{c}{f}$$

Using this formula one can calculate the wavelength knowing the frequency and vice versa. For example, wavelength of an FM transmitter emitting at $f=100$ MHz frequency is $L=3 \cdot 10^8/100 \cdot 10^6=3$ m. Similar to that, wavelength of Radio Belgrade 1 is $L=439$ m, which makes its frequency equal to $f=3 \cdot 10^8/439=684$ kHz.

Radio diffusion is being performed in certain parts of the wavebands given in Table 1, their boundary frequencies are (rounded values):

LW (long waves) 150 kHz (2km) 300 kHz (1 km)
 MW (mid waves) 500 kHz (600 m) 1500 kHz (200 m)
 SW (short waves) 6 MHz (50 m) 20 MHz (15 m)
 FM (ultra short waves) 88 MHz (3.4 m) 108 MHz (2.78 m)

In LW, MW and SW the amplitude modulation is used, while in FM range it is the frequency modulation.

Here are the frequencies (in kHz) of some radio transmitters from the MW range, that can serve for tuning of the radio receivers being described in this issue: Timisoara 630, Belgrade1 684, Bucharest 855, .

Chapter III DIRECT (TRF) RADIO RECEIVERS

[3.1. The Simplest Radio Receiver](#)

[3.1.1. Input Circuit](#)

[3.1.2. The Antenna](#)

[3.1.3. The Ground](#)

[3.1.4. Other Components](#)

[3.2. The Simplest Amplified Radio Receiver](#)

[3.3. Simple Radio Receiver with TDA7050 IC](#)

[3.4. Simple Radio Receiver with LM386 IC](#)

[3.5. Radio Receiver with Increased Sensitivity Audio Amplifier](#)

[3.6. Universal Audio Amplifier](#)

[3.7. Receiver with HF Amplifier](#)

[3.8. The Audion - Direct Receiver with Drain Detector](#)

[3.9.1. Reaction - Type Receiver](#)

[3.9.2. Direct SW Receiver for AM, AM-SSB & CW Signals](#)

[3.10. Miniature Receiver with ZN414 \(ZN414Z\) IC](#)

[3.11. Pocket Receiver with ZN414 & LM386 IC's](#)

[3.12. Miniature Receiver with ZN415E IC](#)

[3.13. Receiver with ZN415 & LM386 IC's](#)

[3.14. Mini Receiver with ZN415 & TDA7052 IC's](#)

[3.15. Direct \(TRF\) FM Receivers](#)

[3.15.1. The Simplest FM Receiver](#)

[3.15.2. The Simplest FM Receiver with Audio Amplifier](#)

[3.15.3. FM Receiver with One Transistor and Audio Amplifier](#)

[3.15.4. FM Receiver with \(just\) One Transistor](#)

3.1. The Simplest Radio Receiver

Each radio receiver must have a reception antenna. It is an electrical conductor, where voltages of various frequencies and amplitudes are being induced, under the influence of electromagnetic fields from various radio transmitters. Besides these voltages, those induced by EM fields that are created by various disturbance sources (such as electrical motors, various household appliances spark-plugs of an automobile and all other devices where electrical current is being switched on/off during work) are also present in the antenna, as well as those from fields originating from outer space or the Earth's atmosphere. Basic roles that a radio receiver has are:

- a. To separate the signal (voltage) of the radio station that it is tuned at from the multitude of other voltages, whilst suppressing (weakening) all other signals as much as possible,
- b. amplifies the extrapolated signal and take out information from it and
- c. reproduces that information, i.e. restores it into its' original shape.

Even the simplest radio, the one we are discussing in this chapter, must be able to accomplish all these tasks. The electronic diagram of one such device is given on Pic.3.1. It is the famous (years ago) Detector Radio Receiver or shortly, Detector. The signal selection (separation) and voltage amplification are performed in the oscillatory circuit that is

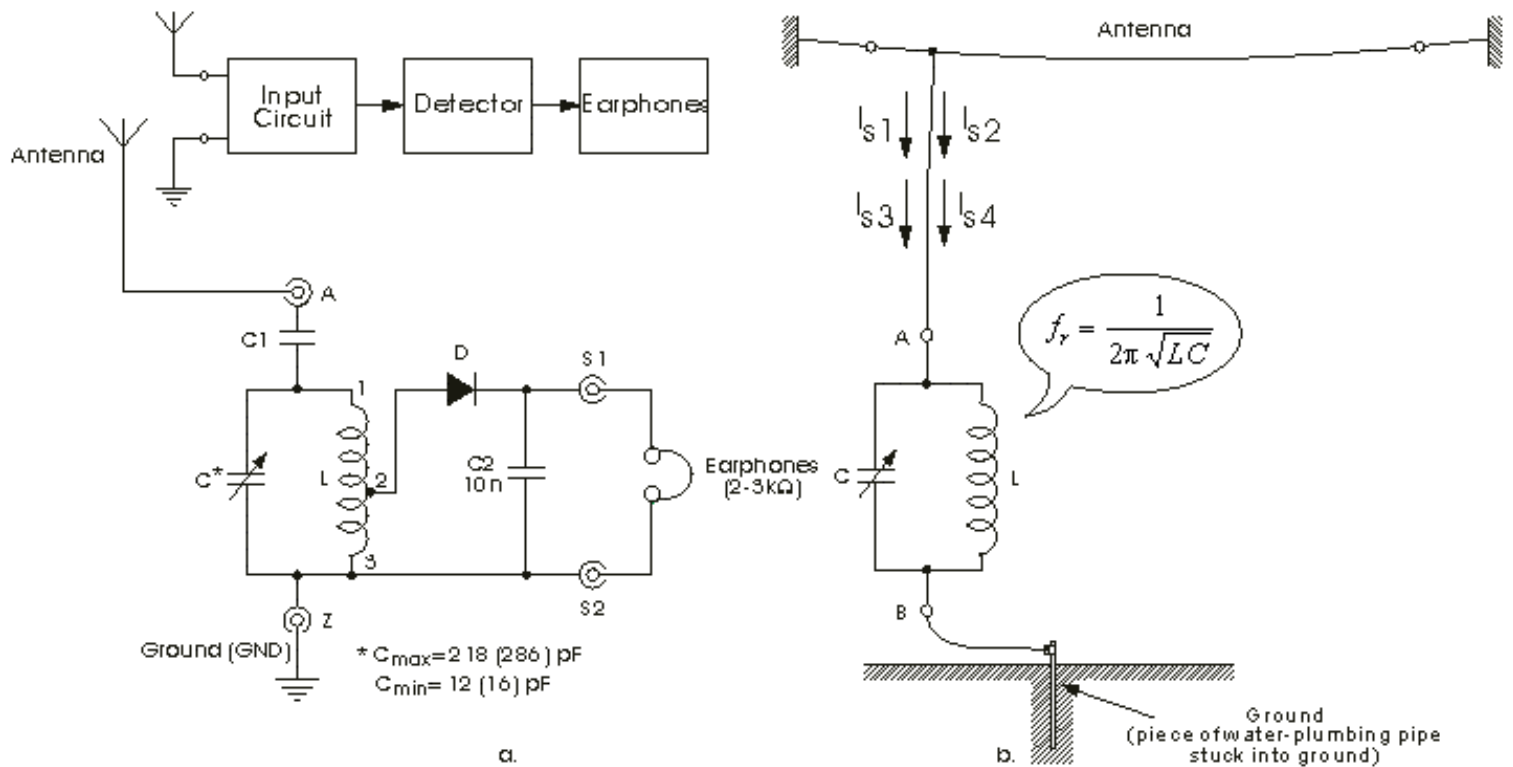

Fig. 3.1- a-Block diagram and electronic diagram of a detector radio receiver, b-operating principle of input circuit

made of the capacitor C and coil L, the separation of information (speech or music) from the AM station signal in the detector that comprises the diode D, capacitor C2 and resistance of the headphones, and information restoring in the very headphones.

Main advantages of this device lie in its extreme simplicity and the fact that it requires no additional energy sources for its' operation. All the energy required it draws from the antenna, which therefore has to be at least a dozen metres long for proper operation. It is also useful to have a good ground. One can do without it but the reception with it is truly better, especially considering the distant and small-power transmitters.

3.1.1. Input Circuit

The capacitor that takes the signal from the antenna (so-called coupling capacitor) C1, variable capacitor C and coil L form the input circuit of the radio receiver. Its main role is to separate the signal of station the receiver is tuned at from multitude of voltages (having various frequencies and amplitudes) existing in the antenna, amplify that signal and turns it over to the detector.

In order to better understand the requests that are to be fulfilled during the practical realization of input circuit, it is necessary to know basic characteristics of circuit made of capacitor C and coil L. It is called 'The oscillatory circuit' and is shown on pic.3.2-a. The amount of its impedance (resistance to AC current) between points A and B, which is marked with Z , depends on the frequency, as it is shown on the diagram on pic.3.2-b. The most important characteristic of this circuit is its resonance frequency, being given by the Thomson's formula:

$$f_r = \frac{1}{2\pi\sqrt{LC}}$$

As one may notice, the resonance frequency depends on the capacitance of the capacitor C and inductivity of coil L, and changes if one of them change. In our receiver, a variable capacitor is used, that can change its capacitance from C_{max} to C_{min} , therefore changing the resonance frequency in boundaries from

$$f_d = \frac{1}{2\pi\sqrt{LC_{max}}} \quad \text{to} \quad f_g = \frac{1}{2\pi\sqrt{LC_{min}}}$$

The area between f_d (lower boundary frequency) and f_g (upper boundary frequency) is the reception area of the input circuit, as shown on pic.3.2-b. On this picture, carrier frequencies of four radio transmitters are being marked with f_{s1} , f_{s2} , f_{s3} and f_{s4} . The resonance frequency of the oscillatory circuit is set (by means of C) to be equal to the carrier frequency of the second station: f_{s2} . In that case, the impedance Z_{AB} - frequency dependence is shown in continuous line. As one can see, the impedance Z_{AB} for all received signals whose carriers have frequencies less than f_{s1} and greater than f_{s3} is less than 20 kOhms, while for the station that is tuned it is equal to 200 kOhms. Let us now imagine that the parallel oscillatory circuit is connected with the antenna and ground, as shown on pic.3.1-b. Imagine, also, that there are (only) four voltages in the antenna, that have the same amplitude and are created by four radio

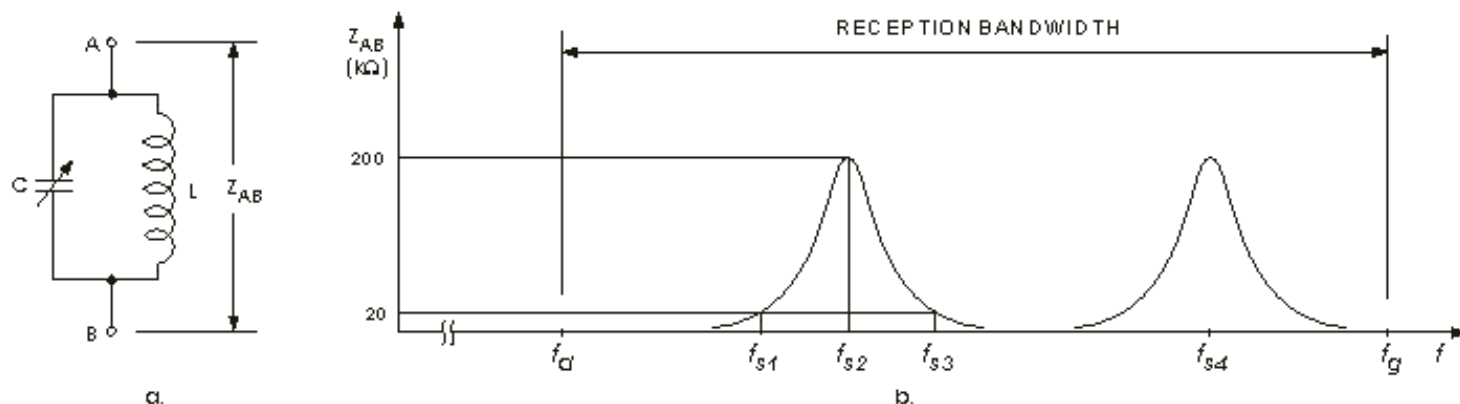

Pic. 3.2 a-parallel oscillatory circuit, b-impedance - frequency dependence of the parallel oscillatory circuit

transmitters, having carrier frequencies of f_{s1} , f_{s2} , f_{s2} and f_{s4} . Since these voltages spread between the antenna and the ground, four currents will flow through the oscillatory circuit: I_{s1} , I_{s2} , I_{s3} and I_{s4} . The voltages that are created by them in the oscillatory circuit, between points A and B, are equal, acc. to Ohm's Law, to the product of current and impedance: $U_{AB} = I \cdot Z_{AB}$. Acc. to pic.3.2-b, for I_{s2} , impedance of the circuit is $Z_{AB} = 200$ kOhms, and for currents I_{s1} and I_{s3} it is 10x smaller. That means that the voltage that is being created in the oscillatory circuit by the station that transmits on frequency f_{s2} will be ten times greater than the voltages being created by stations transmitting on frequencies f_{s1} and f_{s3} . This is how selection of one station is performed, by means of the oscillatory circuit. Transition to some other station is performed by changing the capacitance of capacitor C , as long as the resonance frequency of the oscillatory circuit does not become equal to the carrier frequency of that station. If its frequency happens to be f_{s4} (acc. to pic.3.2-b), the impedance of the oscillatory circuit for that case is shown in dashed line, which causes that on the circuit output voltage of the station that transmits on frequency f_{s4} is acquired, while other stations' signals are suppressed.

At first glance, everything is just the way it should be: Parallel oscillatory circuit extrapolates one and suppresses all other stations. Unfortunately, the reality isn't so simple. First of all, radio transmitters operate with various output (emission) powers and on various geographic distances from the receiver, therefore making the voltages that their signals create in the reception antenna very different in amplitude. It is clear that stronger signals will "cover" the weak ones, thus disabling their reception. E.g. if radio transmitter that emits on the frequency f_{s1} is geographically much closer to our radio receiver than the transmitter operating on f_{s2} , the voltage the former creates in the reception antenna can be even 200 times greater than the one created by the latter. The oscillatory circuit will do its job as previously described, but on its ends the voltage of the first transmitter will still be greater (20x) than that of the transmitter the receiver is tuned at, and normal reception won't be possible. There are also other problems whose solving will not be discussed herein, and readers that are interested in those can read a book "Radio Receivers", written by Momir Filipovic, issued by the National Textbook Publishing Company from Belgrade, Yugoslavia.

To conclude this chapter, we may say that the simplest radio receiver can cover only signals of the local and powerful radio transmitters.

3.1.2. The Antenna

Extremely important factor for good work of simple radio receivers is the outside antenna that has to be long enough, and in which voltages induced by the radio transmitters will be high enough. At first sight, one can think of using instead some modest antenna made of a piece of wire, compensating that with supplying the receiver with amplifier strong enough to give the end result as if much better antenna have been used. That, of course, is not the case, since every amplifier creates noise that makes the reception worse, if not impossible. This fact is the cause for a radio-amateur saying that "Antenna is the best HF amplifier." The external (outside) antenna is being made of copper wire, thick enough to resist strong wind conditions. In the sense of mechanical strength, the best thing is to use the litz wire (cable), i.e. a cable made of huge number of thin threaded copper wires. There is no need to remove the wire isolation if it exists since it doesn't represent an obstacle for the electromagnetic waves. The length of antenna is being determined in accordance with the "TLTB" law (The Longer, The Better). The antenna that we have been using for testing the receivers described herein was 6 metres long (the length of the Radio Receivers Lab at "Tesla" highschool, where it was spread), but if you are in position, you should make it even longer (the author has a friend whose antenna is about 30 metres long). It should be moved away from the sources of electrical disturbances (public electricity cables, various household electrical devices, cars, electric motors etc.). Considering this, the best place for your antenna should be the building roof. The wire can be crossed between two chimneys (Pic.3.3), between a chimney and some pillar, between two purposefully built pillars, between two buildings, a building and a pole in the yard etc. You should, however, always keep in mind that the wire, however strong it may be, can snap during some big storm and, in case that happens, under

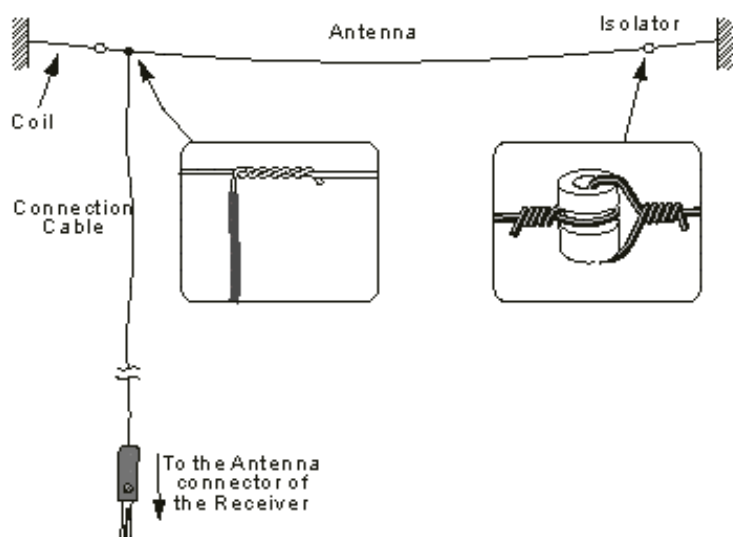

Pic.3.3. Outside Antenna

NO CIRCUMSTANCES it should fall onto electrical network cables, telephone leads and similar, or to cause some other damage. If your roof cover is not covered with tin, the attic could also be a good place for the antenna. You can also stretch it between two stronger laths attached to two opposite window frames of your apartment. If you have no other options, you can put your antenna between the walls in your room.

The antenna must be electrically isolated from the carriers being attached to. In amateur conditions, one can make the isolators of a piece of thick wall plastic pipe where, acc. to Pic.3.3, an indent should be made with the round rasp, in order for the wire not to slip away.

The antenna lead is another piece of wire which carries the signals from antenna into the receiver. It should be isolated and placed in such a way not to touch the walls, to be as far from metal parts as possible (gutters, city grounding etc.).

At the end of this chapter, let's just say that in mobile receivers ferrite antennas are being used, which we are going to talk about later.

3.1.3. The Ground

As all other sorts of ground, the ground for the radio receivers is being accomplished by connecting the receiver ground

(point Z on Pic.3.1) to Earth over a copper wire. You can live without the ground but the reception is much better with it though, especially considering simple devices, such as one at the Pic.3.1-a. Water plumbing is an excellent ground (central heating pipes are not), but it is most often inappropriate for use. There is no housewife that would agree to have some dreadful wire stretched across the house, from bathroom to the living room! House electrical installation's ground is excellent, but it should be used under NO circumstances, since life-threatening danger from electrical shock exists. If you live on a ground floor, and there's plain soil beneath your window you can make your own ground by sticking a pipe into it, acc. to Pic.3.4. The pipe should be about 80 cm long, and on its end you should connect the receiver ground, attaching it with a metal ring and a screw with the nut.

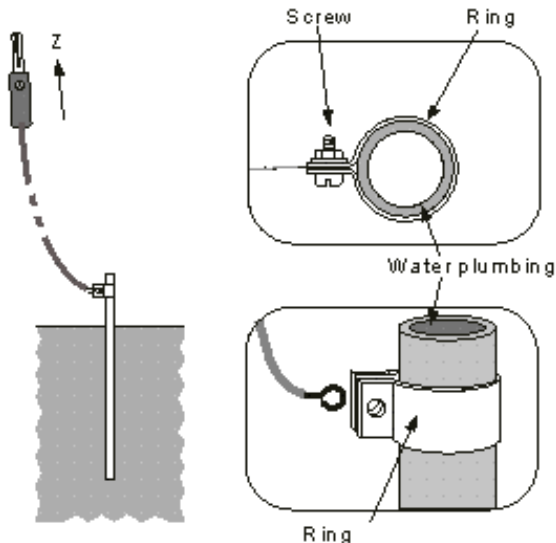

Pic.3.4. The Ground

3.1.4. Other Components

- On Pic.3.1-a with letters A, Z, S1 and S2 the hubs where one can connect the antenna (A), ground (Z) and the headphones (S1 and S2) are labelled. Since the cabinet for our radio receiver(s) is being made of material that is the electrical isolator (plywood, plastics etc.), the simplest metal hubs can be used, although hubs with isolation plates (for metal plate mounting) can be found in shops more easily, but are significantly more expensive.
- C1 capacitor is the so-called coupled capacitor, through it the signals from the antenna being led into the oscillatory circuit. Its capacitance depends upon the length of the antenna, and it lies within the limits of few pF (antenna longer than 10 m), up to few dozens pF (a couple of metres long antenna), the optimal value is to be found through experimenting. Every reception antenna behaves as a voltage generator, having its own internal resistance and capacitance. Antenna's resistance damps the oscillatory circuit and reduces its selectivity (which manifests as the "mixing" of stations) and sensitivity (which exerts as signal strength reduction), and antenna's capacitance reduces the reception bandwidth. More precise, antenna's capacitance reduces the upper bound frequency of the reception bandwidth (Pic.3.2), making reception of the stations laying close to this frequency impossible. Both these features are undesirable and manifest themselves as less as the capacitance C1 is smaller. On the other hand, the smaller the capacitance C1, the weaker the signal that goes through it from the antenna, the reception therefore getting weaker. As you can see, the compromise solution is a thing to go for, i.e. one must find the capacitance at which the signals from the antenna won't be much weakened while simultaneously keeping the selectivity and the bandwidth big enough. You can start with C1 being about 30 pF. Then, using C, tune yourself to some radio stations you can receive. If all the stations that interest you are there, and the strongest one of them still does not jam the reception of other stations all's well. Try then with some bigger capacitance for the capacitor C1. The reception will be getting louder, so do continue increasing C1 as long as it is still possible, by changing C, to receive all the stations of your interest that can be heard in your place, without the interference of some strong or local station. If, however, reception of some nearby station isn't possible, smaller C1 should be tried out. In this manner the biggest capacitance for C1 should be found, that allows optimal reception both regarding selectivity and bandwidth. The simplest solution is using variable capacitor for C1, its capacitance ranging from few picofarads to few dozens pF, adjusting it to obtain optimal reception for each station individually. During this, whenever C1 is being changed, the receiver must be re-tuned to the station using C.
- The coil is one of the components that cannot be bought, therefore it has to be manufactured. Its main property is the inductance L. As an example, we are going to take a look at how to build a coil for the MW receiver with band range from $f_d=540$ kHz til $f_g=1620$ kHz. The inductance is being calculated using the Thomson formula (being solved by L):

$$L = \frac{1}{4 \pi^2 f_g^2 (C_{\min} + C_x)}$$

Where C_x denotes the so-called parasite capacitance. It comprises the capacitance of the trimmer capacitor (its average value) that is connected parallel to the variable capacitor C , input capacitance of the next stage of the receiver (where the signal from the input circuit is being lead), antenna capacitance, coil capacitance and capacitance of the connections between the components of the input circuitry. The amount of this capacitance is not known in advance, therefore must be assumed. Taking that value, the coil inductance is calculated and the appropriate coil is made, together with the input circuit. The error being made with the assumption of the capacitance C_x is then compensated with the abovementioned trimmer capacitor. In all our projects this capacitor had minimum capacity $C_{\min}=12$ pF. We assumed $C_x=15$ pF, and therefore:

$$L = \frac{1}{40 \cdot 1,62^2 \cdot 10^{12} \cdot (12 \cdot 10^{-12} + 15 \cdot 10^{-12})} = 353 \mu H$$

We made this coil, conented it with other components from Pic.3.1 and, after some experimenting and measurement, came upon the conclusion that its inductance should be somewhat smaller. We uncoiled a few reels, re-checked the bandwidth, then uncoiled some more, re-checked again, and after several tries came up with the solution. With variable capacitor that will be described in the following chapter, the abovementioned bandwidth is achieved with the coil of inductance $L=330$ iH (microhenries).

The coil body i.e. the body where the coil is being reeled is a cylindrically shaped isolation material. For this purpose we have been using the carton core of the household aluminium foil package, its diameter being 3.2 cm. The number of bends required and wire diameter are calculated acc. to the formulas from Pic.3.5.

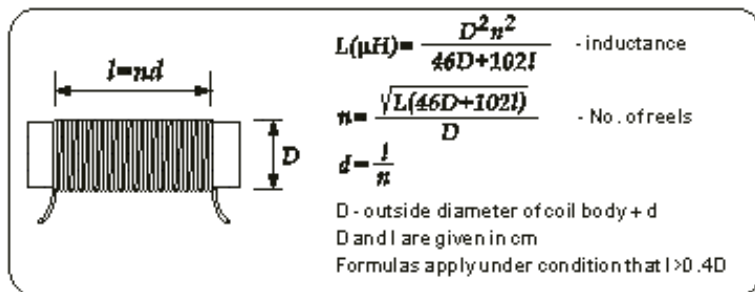

Pic. 3.5. Formulas to calculate the coil inductance and number of reels

In order to use these expressions coil length must be assumed first. If this length later proves to be incorrect because the wire is too thick or thin, new length is adopted and the calculation is repeated. Let us assume that coil length is $l=4$ cm. The number of reels and coil diameter are:

$$n = \frac{\sqrt{330 \cdot (46 \cdot 3,2 + 102 \cdot 4)}}{3,2} = 134$$

$$d = \frac{40 \text{ mm}}{134} = 0,298 \text{ mm}$$

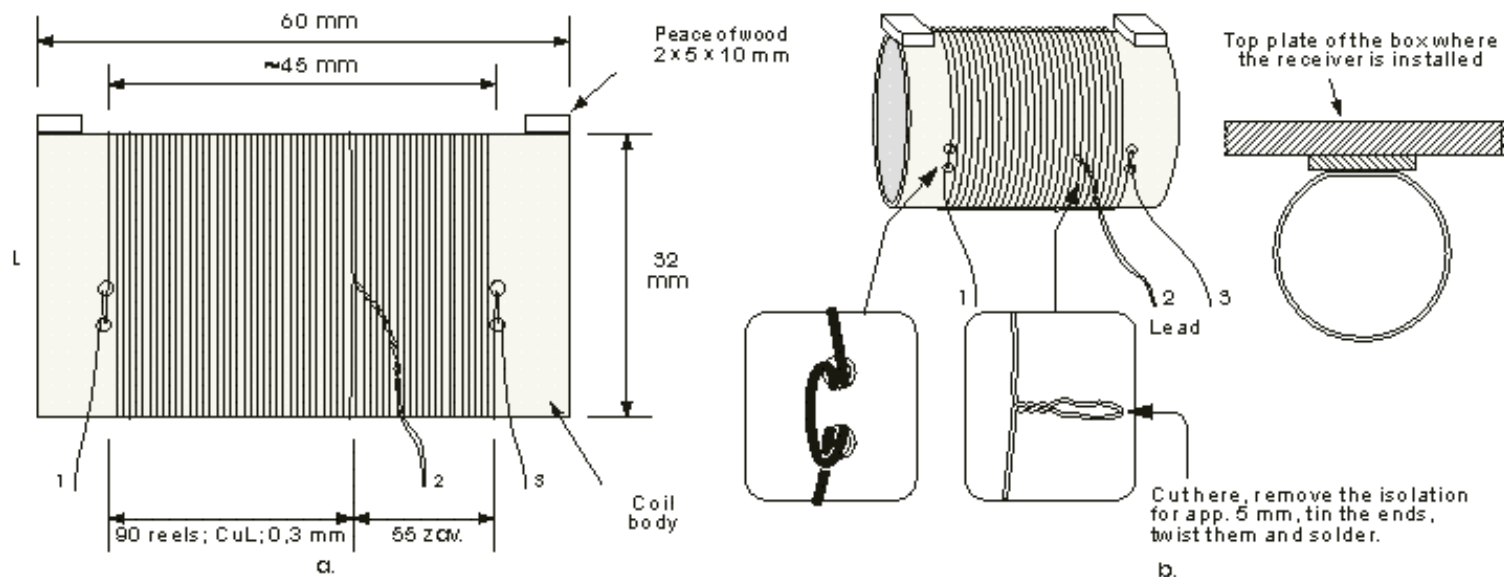

Pic.3.6. Coil of radio receiver's input circuit: a-dimensions, b-layout and details

Since there is no wire of such diameter, we adopt the closest existing value, $d=0.3$ mm. In that case the length l will be somewhat bigger, and so will be the number of reels. After a few iterations in calculus and later inductance check of the finished coil, we came upon the $n=144$ reels of lacquered copper wire (the mark for such wire is CuL), its diameter being $d=0.3$ mm.

This coil is shown on Pic.3.6. As you can see, two holes are made in coil body (with a bodkin) and through them the wire origin is being threaded twice. After that 90 reels are made, then a leg, then another 55 reels and finally the wire end is again threaded twice, through the other two holes. The leg is made by multiple twisting the wire. It is then cut, and from these new ends about 5 mm of isolation is removed, after which they are tinned, twisted around each other and finally, soldered (the easiest way to remove the isolation is by burning it with lighter, then carefully scrapping it with the pocket knife or similar). Two small pieces of wood are then glued onto coil's ends. When the coil is being mounted into the box, they are pasted onto its top panel, as shown in the rightmost part of Pic.3.6-b.

If you are using a coil of different diameter, you should keep in mind that the necessary inductance for the coil which measures more than 3.2 cm in diameter will be obtained with number of reels less than 144 and vice versa, if the coil body is less than 3.2 cm you will need more than 144 reels.

d. Variable capacitor C is hard to find in stores, thereby we have been using in all our receivers the one that we took from a disused commercial pocket size MW radio receiver, the one shown on Pic.3.7. On Pic.3.7-a you can see it together with the reel with numbers that represent the frequencies, divided by 100, on which that receiver was able to be tuned at. On Pic.3.7-b you can see the front, side and rear views of this capacitor. Electrical diagram is given on Pic.3.7-c. As one may notice, there are actually two variable capacitors under the same cover, C_o and C_a , and two trimmer capacitors connected parallel to them, C_{to} and C_{ta} . The dashed line shows symbolically that the rotating plates of the variable capacitors are connected on a common shaft, so that by turning the reel their capacitances are being changed simultaneously. For our use, all four capacitors are parallel connected, by joining the legs O and A. The trimmers are set to minimal capacitance. In such way the variable capacitor is attained with capacitance ranging from $C_{min}=12$ pF til $C_{max}=218$ pF.

In commercial radios that can receive both stations from AM and FM ranges, variable capacitor shown on Pic.3.8 is being used. Four variable and four trimmer capacitors are placed under the same cover. If you wish to use capacitor like this in the receiver from Pic.3.1 (and in most of the receivers described in this book), you should then connect in parallel C_{to} , C_o , C_a and C_{ta} , after which you shall obtain a variable capacitor ranging from $C_{min}=16$ pF til $C_{max}=286$ pF. Other capacitors from this block are not being used.

In all input circuits (more about them soon to come), one end of the variable capacitor is always connected to the device ground. For capacitors shown on Pics.3.7 and 3.8 that is the middle leg, marked as G.

During the dismounting of the capacitor from the old radio, you should pay attention not to loose the screw for the reel attachment, and two screws for mounting the capacitor onto the PCB, since they are very hard to provide separately.

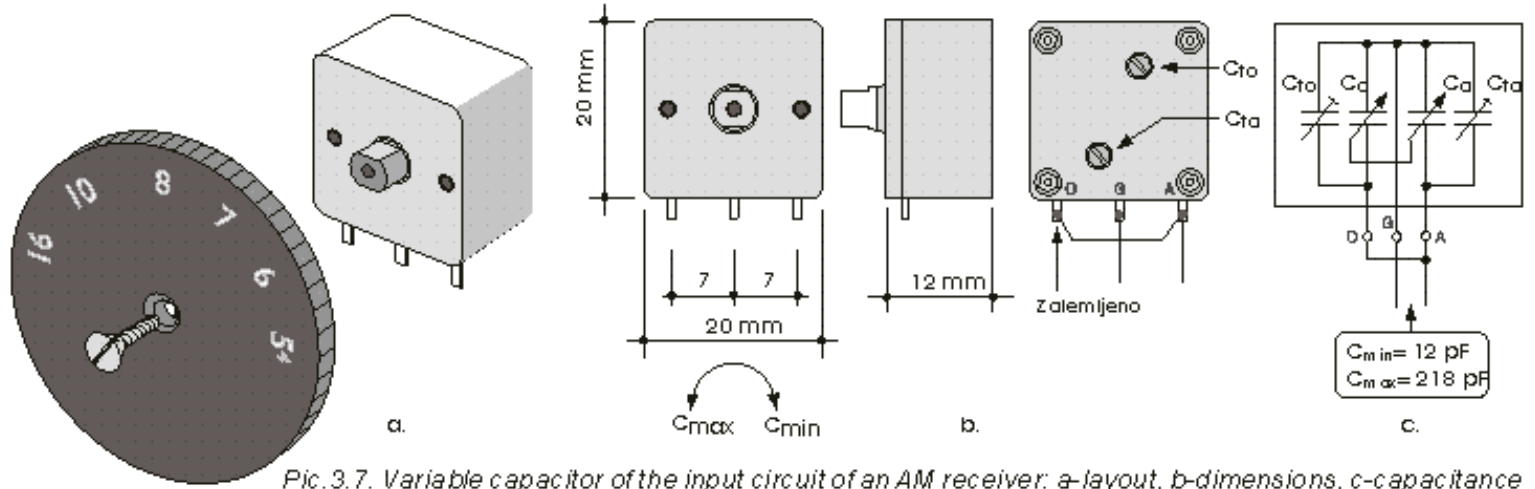

Pic. 3.7. Variable capacitor of the input circuit of an AM receiver: a-layout, b-dimensions, c-capacitance

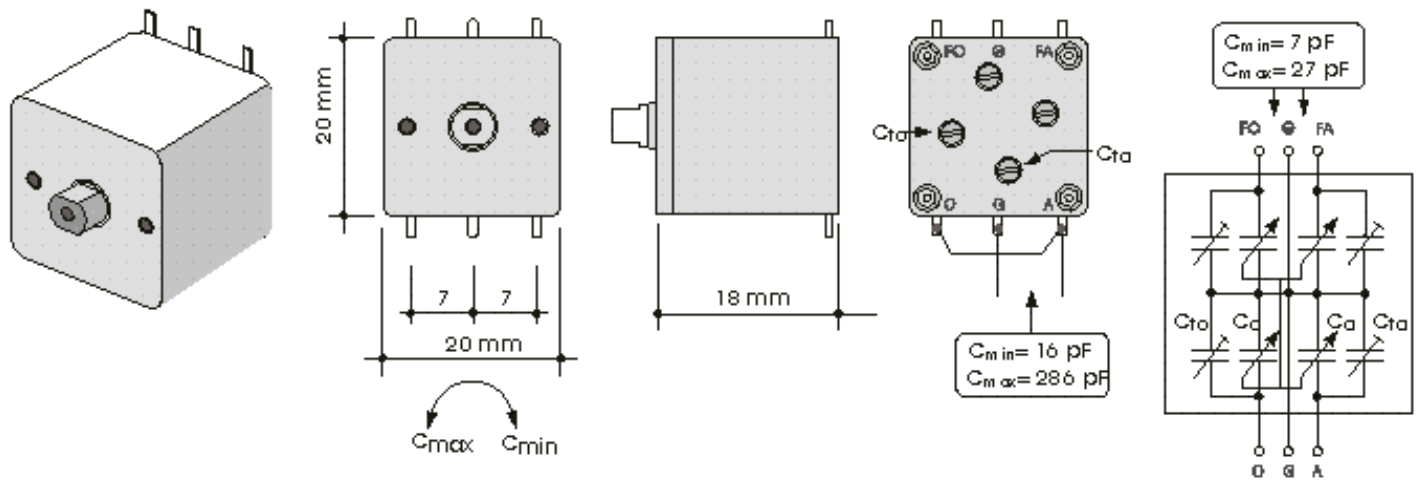

Pic. 3.8. Variable capacitor of the input circuit of an AM/FM receiver: a-layout, b-dimensions, c-capacitance

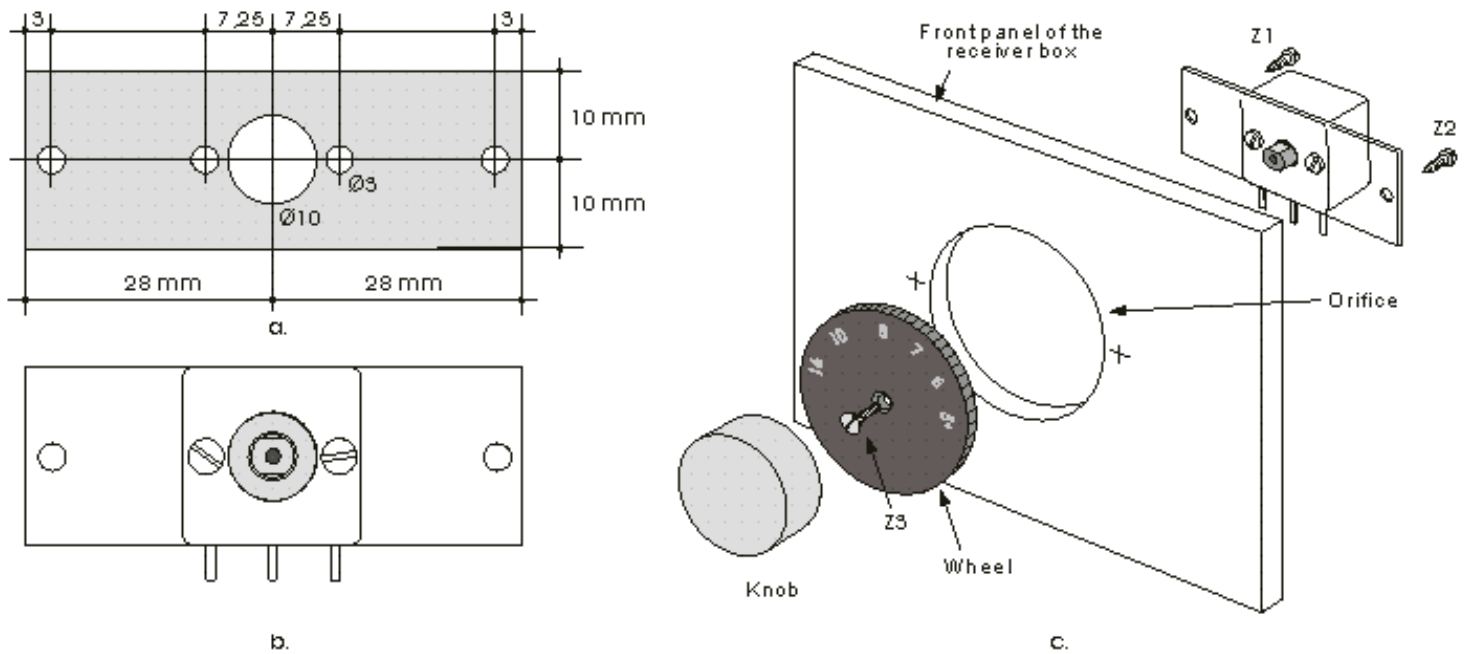

Pic.3.9. Variable capacitor assembly: a-plate dimensions, b-capacitor on plate, c-assemblage on the front receiver panel

If the receiver is being put into the box whose front panel is made of isolating material not thicker than 1 mm, then one 10 mm hole should be drilled on it, followed by two 3 mm holes, as shown on Pic.3.9-a. Having thicker front panel does represent a problem, the shaft of the capacitor being too short to mounting the reel. In that case you will have to make the auxiliary plate about 1 mm thick as shown on Pic.3.9-1 and then mount the capacitor on it, acc. to Pic.3.9-b. On the front panel a round eye should be made, its diameter being a little bit bigger than the reel. The auxiliary plate with the capacitor should then be tightened onto this front panel with two small screws Z1 and Z2, and the reel on the capacitor shaft with the screw Z3 (While tightening this screw you should hold the reel with your other hand, and not the capacitor housing). Finally, a button made of a thick plywood can be glued to the reel. This is not necessary, but gives the device a more sophisticated looks.

Different variable capacitors than the ones described here can also be used, for example, an air variable capacitor described in the first issue of Practical Electronics. The important thing for it is to have a big max/min capacitance ratio, at least 15, i.e. $C_{max}/C_{min} > 15$. While connecting the capacitor, care should be taken to connect its rotor with the ground (as on Pic.3.1), labeled Z, and its stator with the point 1 of the coil.

e. The diode D, capacitor C2 and headphones' resistance comprise the AM signal detector, also called the serial diode detector. When the AM signal of the station the receiver is tuned at is brought on its input, NF signal is obtained on the output, its shape being the same as the envelope of the AM signal. An example of this is given on Pic.3.10. When voltage u_{ul} is present on the input of the detector, the voltage u_{izl} appears on its output. It is useful to notify that on the output, besides the LF voltage (speak, music etc.), DC voltage U_0 is also present.

The detection diode D must be of low- power GERMANIUM type, such as AA112, AA116, AA121, 1N21, 1N34, 1N54, 1N78 etc.

Product of the capacitance C and resistance R (on Pic.3.1. R is the headphones resistance) should be approx. equal to 50 is (microseconds). That means that if you're using the bigger resistor (which is advisable, since the detector then damps less the oscillatory circuit), the capacitor should then be smaller. For example, if $R = 500 \text{ k}\Omega$ then $C = 100 \text{ pF}$, and if $R = 10 \text{ k}\Omega$, $C = 5 \text{ nF}$, etc.

f. The headphones are the electro acoustic convertor that transforms electrical signal into the sound. We have been using old fashioned electromagnetic headphones with $1.5 \text{ k}\Omega$ resistance that were serially connected, giving the total resistance of $3 \text{ k}\Omega$. The receiver from Pic.3.1 will be working as better as headphones' resistance is bigger. if you're using the crystal headphones, parallel to them you should add a resistor of couple of hundreds of kiloOhms. There's a very simple way of testing the high resistance headphones: Hold one end of their cable between your fingers while rubbing the other over the surface of a big metal object, say, the radiator. If snapping can be heard from them they are, most likely, satisfactory.

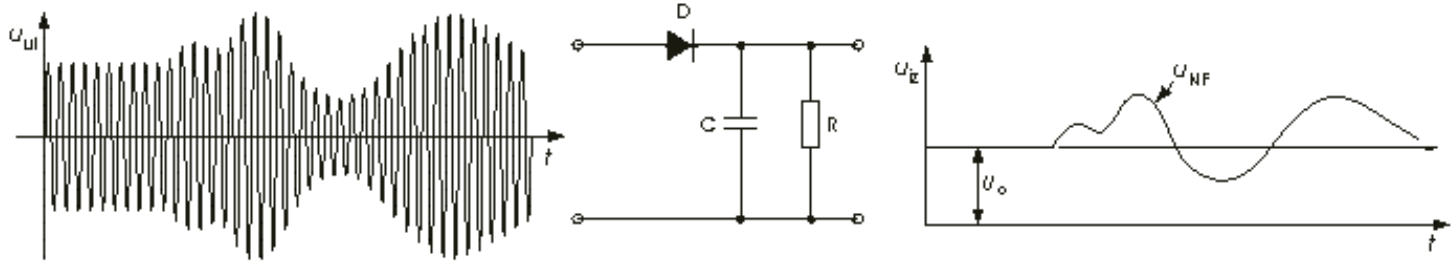

Pic.3.1. Input and output voltage at the serial diode detector

All the components of the receiver from Pic.3.1 should be placed into some kind of a box. That can be any box made of an isolation material (plastics, wood etc.), big enough to receive all the components. As an example, a receiver is shown in scale 1:1 on Pic.3.11, being placed in a box made of plywood. The top, bottom and side panes are made of plywood that is 5 10 mm thick. The front and the rear side are being made of some thinner material, that allows for simple mounting of the variable capacitor. One can notice straightaway that the box is at least twice as big as it could be. That has been done for the sake of better visibility, and for the box to be big enough to accept the devices that will be described later in this book.

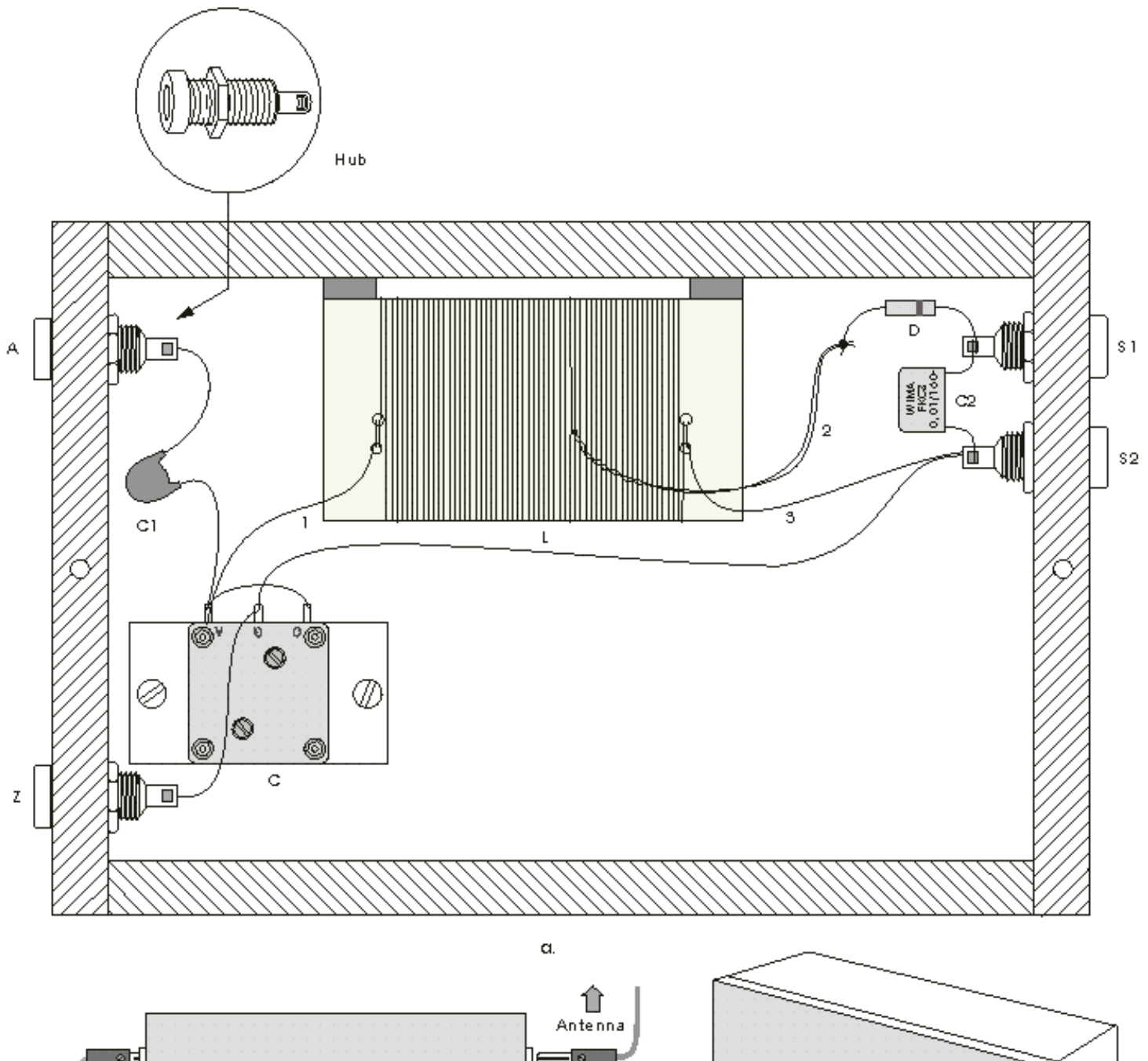

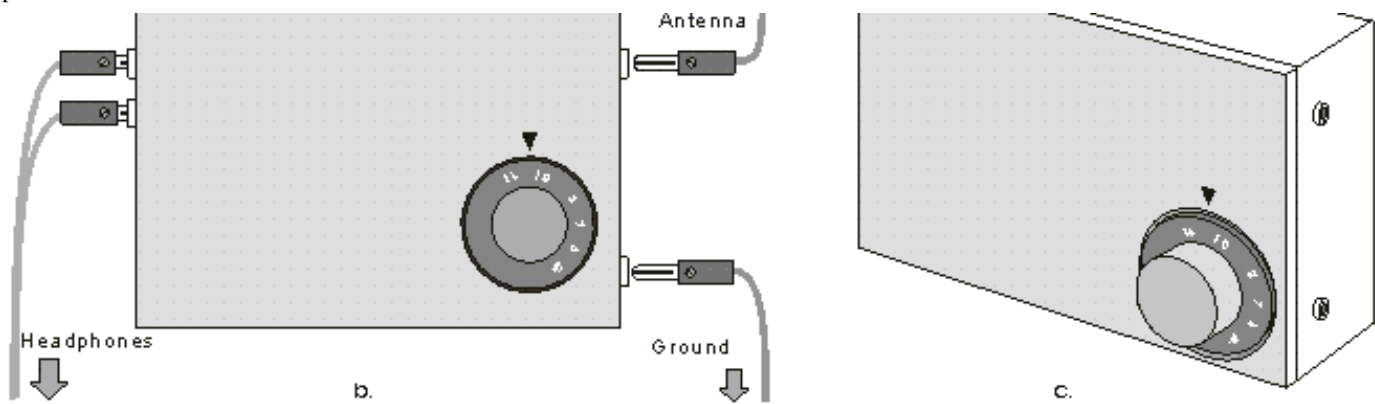

Pic. 3.11. Practical realization of the Detector Receiver from pic. 3.1-a: a-component layout in the box, b-front panel view, c-3D view

Component joining is being done by soldering. Performing soldering onto the hubs can represent a small problem. In order to complete this operation successfully, you should turn the box for the part of hub where cables are being soldered pointing upwards. Put a piece of the tinol wire through the eye on the hub, put the soldering iron top onto the eye from upwards and hold it like that a while, for the tinol to melt. Then add some more tinol, until the eye is completely covered with the solder. After that, push the wire end into the melted solder while holding it with pencers, until it hardens and cools itself a little. The pencers remove the heat and prevent its transfer onto the component that is being soldered.

3.2. The Simplest Amplified Radio Receiver

The most obvious shortcoming of the receiver described in the previous chapter is that it can perform the sound reproduction loud enough only in case when the programme from some local or very powerful radio transmitter is being received, which can create very strong signal in the reception antenna. The reception of signals from other transmitters is too weak. The only thing that can be done is either to increase the length of the antenna, which, of course, does have its limits, or to insert an amplifying stage into the receiver. The simplest way to perform the latter is to add a LF amplifying stage behind the detector in the detection receiver, Pic.3.1. The electrical diagram of one such receiver is given on Pic.3.12. The electrical load in the detection stage are no longer headphones, but an ordinary resistor R1. An NF signal is obtained on its ends, which is then being lead into the LF amplifier with the transistor T, over the coupling capacitor C3. The electrical load in the collector circuit of the transistor are the headphones, which transform the amplified LF signal into sound. The voltage negative feedback is being obtained with the capacitor C4, and the current negative feedback with the resistor R3. They enhance the characteristics of the amplifier (increase its stability, reduce distortion, widen the reception band), but they also reduce the amplification. The capacitor C5 prevents the AM signal carrier which, although very weak, also appears on the detector output, from entering the headphones. These 3 components however, can be omitted in most cases, for the sake of simplifying the device. C4 and C5 can be simply removed, and a piece of wire should be soldered instead of R3. Transistor operation point where the optimal reproduction (the biggest amplification, the smallest distortion) is being set by adjusting the resistance value of the resistor R2. The simplest way to do it is to connect the trimmer of couple of M Ω instead of the resistor, set the receiver on some station, then change the resistance until the optimal reception is being reached. The trimmer is then put out, its resistance measured, and a resistor of similar resistivity is then soldered on its place. The transistor T is any universal NPN - type.

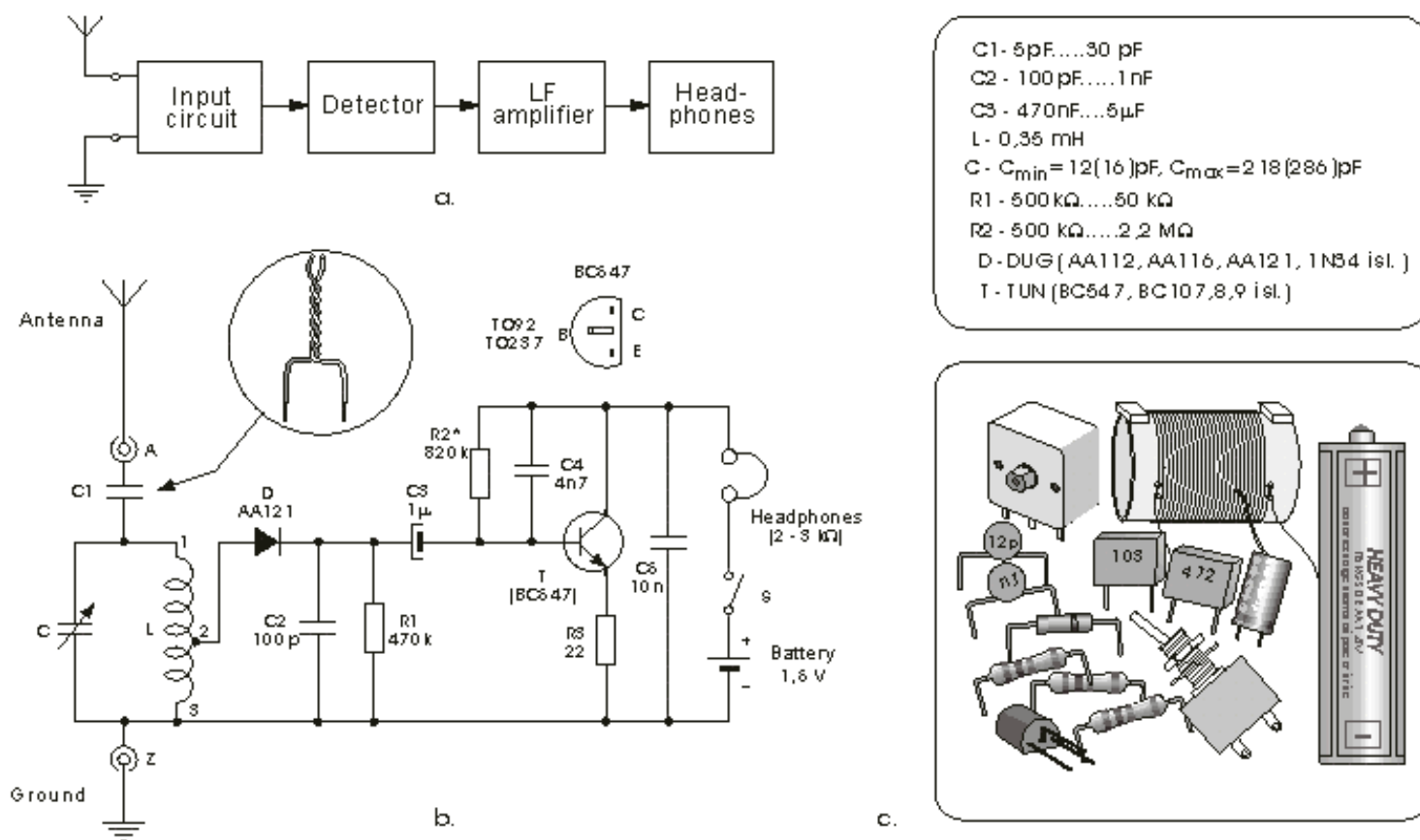

Pic.3.12. Detection receiver with simple amplifier: a-block diagram, b-electronic diagram, c-components

Please note that in the case of a very long antenna, when C1 of very small capacitance is being used, a hand made trimmer capacitor can be used. It is made by twisting two isolated wires, and its capacitance is changed simply by removing some wire from the ends.

The component data is given on the electrical diagram and in table on the rightmost side of Pic.3.12. If you don't have a 100

pF capacitor (C2) you can put some of bigger capacitance, but you should then use smaller R1.

The PCB layout is given on Pic.3.13. On 3.13-a is a picture that should be copied with the thin alcohol marker onto well cleaned copper side of the pertinax plate. Etching is to be performed then, as well as drilling the 0.8 mm holes, in the way that has been described in detail in PE2 issue (Practical realization of electronic devices). The component layout is given on Pic.3.13-b. The printed circuit is also visible on this picture, and that can be achieved by using vitroplast plate instead of pertinax. The look of board upon completion is on 3.13-c. Before soldering the wires that connect the variable capacitor, battery, switch etc. with the board, put some tin on the wire ends, using the calofonium or the tinol wire. You should by all means do this, especially if you're not using the wire that is not pre tinned, in order to avoid cold solders, very unpleasant surprises that are hard to detect and locate.

The layout of the entire receiver is given on Pic.3.14, in a scale 1:1. As in the previous receiver example, the coil is being glued to the top side of the box, over two small pieces of wood. The board is being tightened with a screw, that is screwed into a piece of wood being glued to the front end box plate. The battery is attached with a rubber band for the pieces of wood glued at the back plate of the box. We did this, however, only for the sake of having a clear and understandable drawing. Battery can be put inside the box in the same way as before, or some other way.

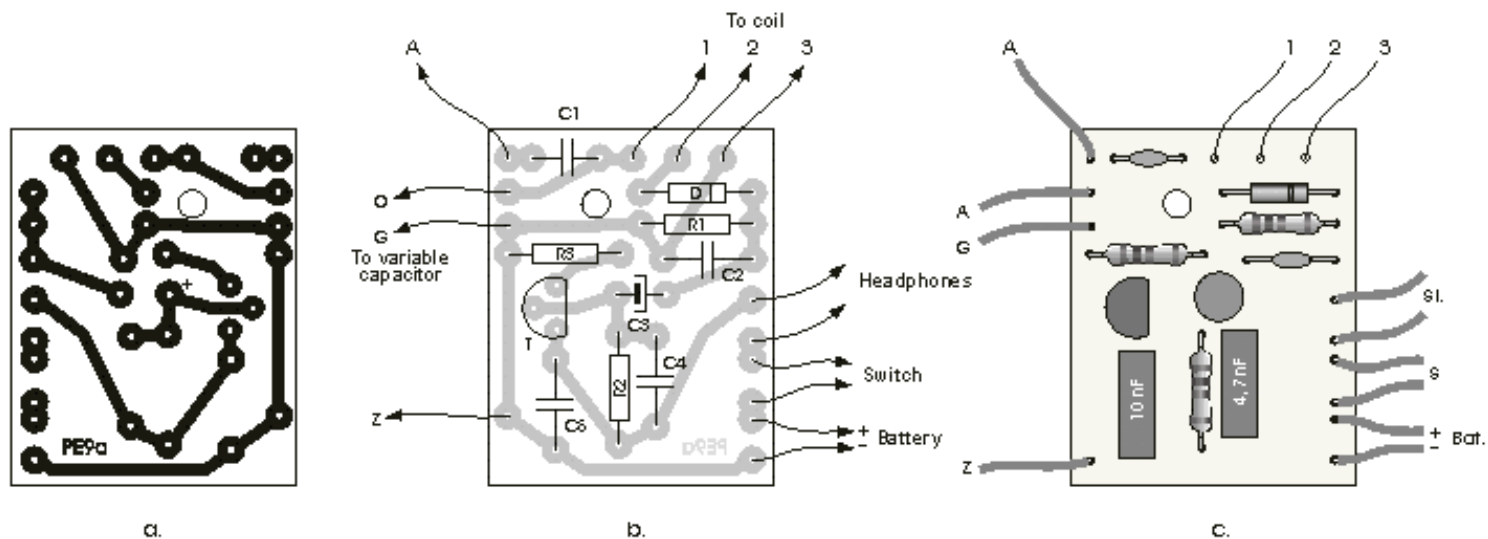

Pic. 3.13. PCB for the receiver from pic. 3.12: a-soldering side view, b-component side view, c-component layout

3.3. Simple Radio Receiver with TDA7050 IC

Readers that were able to browse through book 4 and, especially, book 5 of Practical Electronics edition, were able to convince themselves that there's a huge number of various audio amplifiers built with IC's, therefore amplifiers in discrete technique are practically no more being made. If we add on this the fact that integrated amplifiers outreach their discrete competition both by price and quality, it is then clear why we are going to use them in this book.

Electronic diagram of a simple radio receiver with LF stage built around the TDA7050 IC, where reproduction is being made through modern-type headphones, resistance being 32 or 64 Ω , is given on Pic.3.15. In book 5 of Practical Electronics you have acquainted yourself in more detail with this IC. Let us just repeat that it can be purchased both in 8-pin DIL package that we have been using, and in SO package, suitable for surface mount. Its label in the latter case is TDA7050T and it can also be used without any problems whatsoever. In that case changes on the PCB should be made considering that it is being mounted on the copper side of the board, and that drilling is now obsolete, since the pins are being soldered directly onto the copper foil. You can read the text that follows Pics.4.16 and 4.17 about soldering SMD components. Supply voltage for the IC is in range from 1.6 to 6 V. Idle current is 3 mA on 3 V supply voltage. Voltage amplification is 32 dB (40 x) on 6 V supply voltage and 32 Ω headphones resistance. Maximum output power is 150 mW, more than enough for the headphones amplifier device.

Regarding the Pic.3.15, both input and detection circuit described in two previous projects can be used, We have decided instead, to show you how to use the coil with multiple legs, since it offers more possibilities for experimenting in order to achieve optimal reception. The picture of such coil is given on Pic.3.16, the legs being made as previously described in this book. The first leg (numerated 6) is made after the 15-th quirk, the second (5) after 30-th, the third (4) after 45-th and the last one (2) after 55-th. Number of quirks between the legs isn't critical, you can have even more legs, being arranged more closely to each other. As seen on Pic.3.15, both the antenna and the detector are connected over these legs. Legs No. 4 and 5 have been used, but that is not a must. The closer the leg where antenna is connected is to the ground (point Z), the less it damps the oscillatory circuit (therefore increasing the receiver's selectivity), and less it reduces the reception bandwidth. However, the signal that exits the antenna is then also smaller. The similar thing is with the leg where the diode (its anode

end) is connected: The closer it is to the ground, the less the detector damps and tunes out the input circuit, but the signal being transferred to the detector is also smaller. It is clear now that a compromise must be made: Experimenting with various coil legs, those providing the optimal reception should be found.

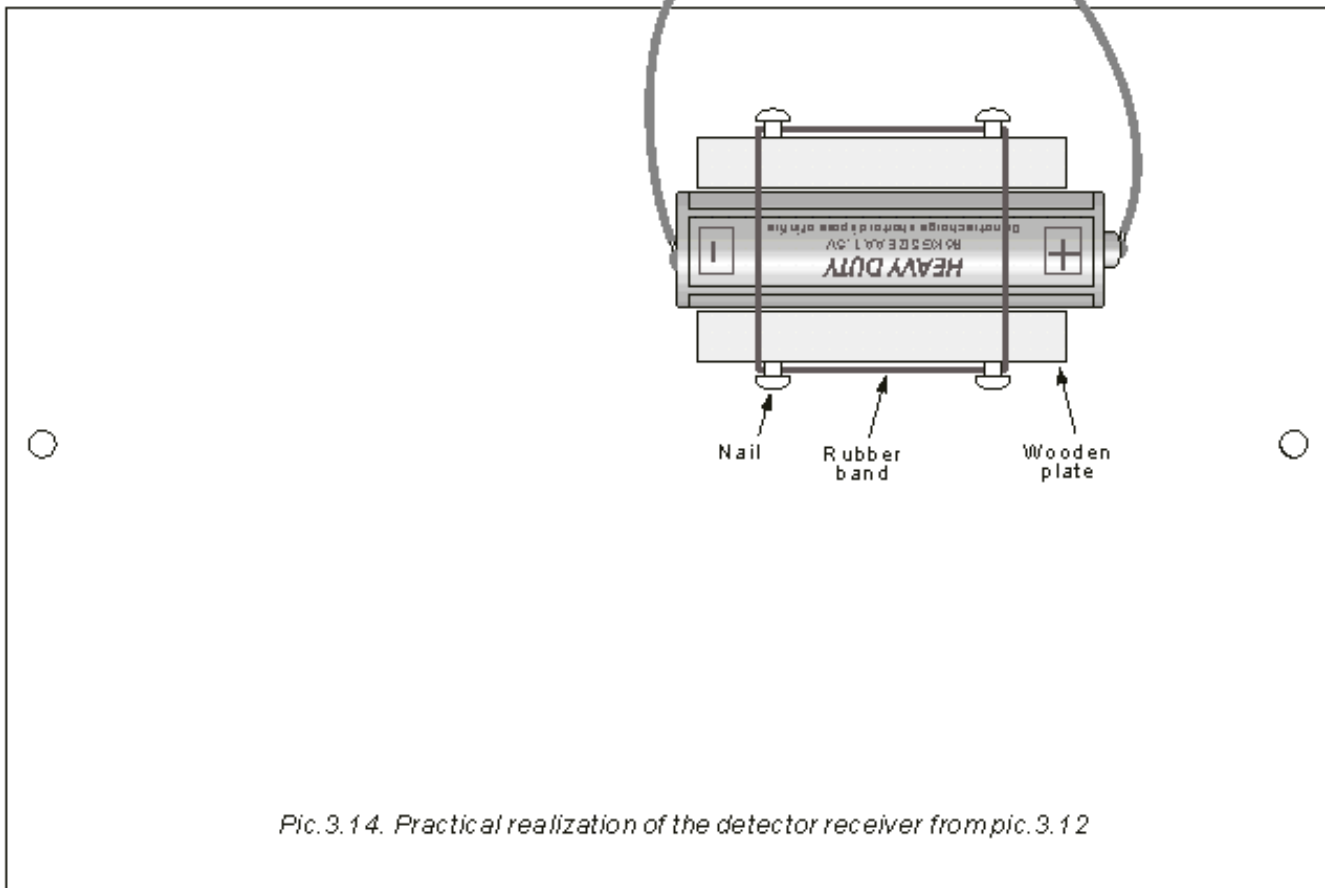
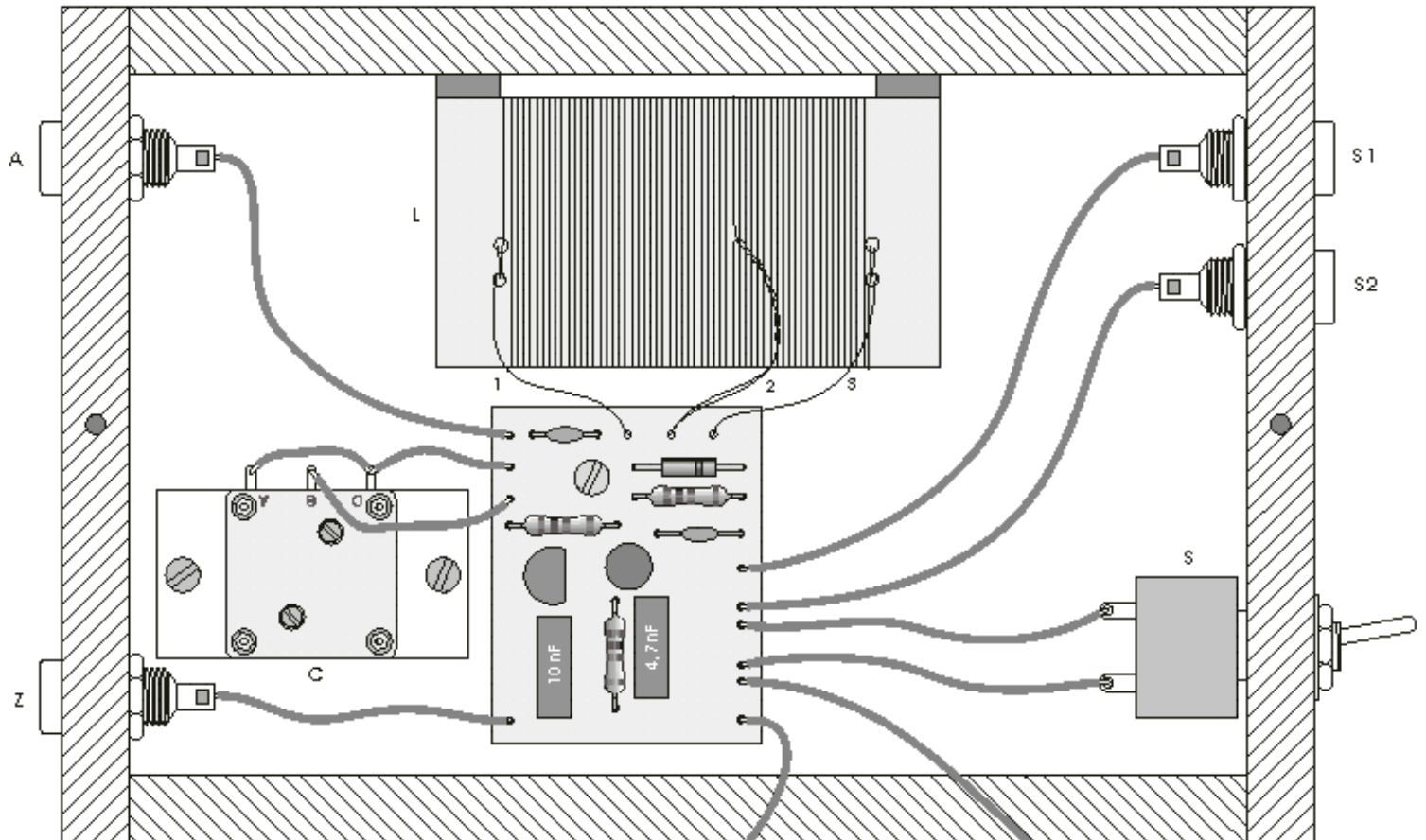

Pic. 3.14. Practical realization of the detector receiver from pic. 3.12

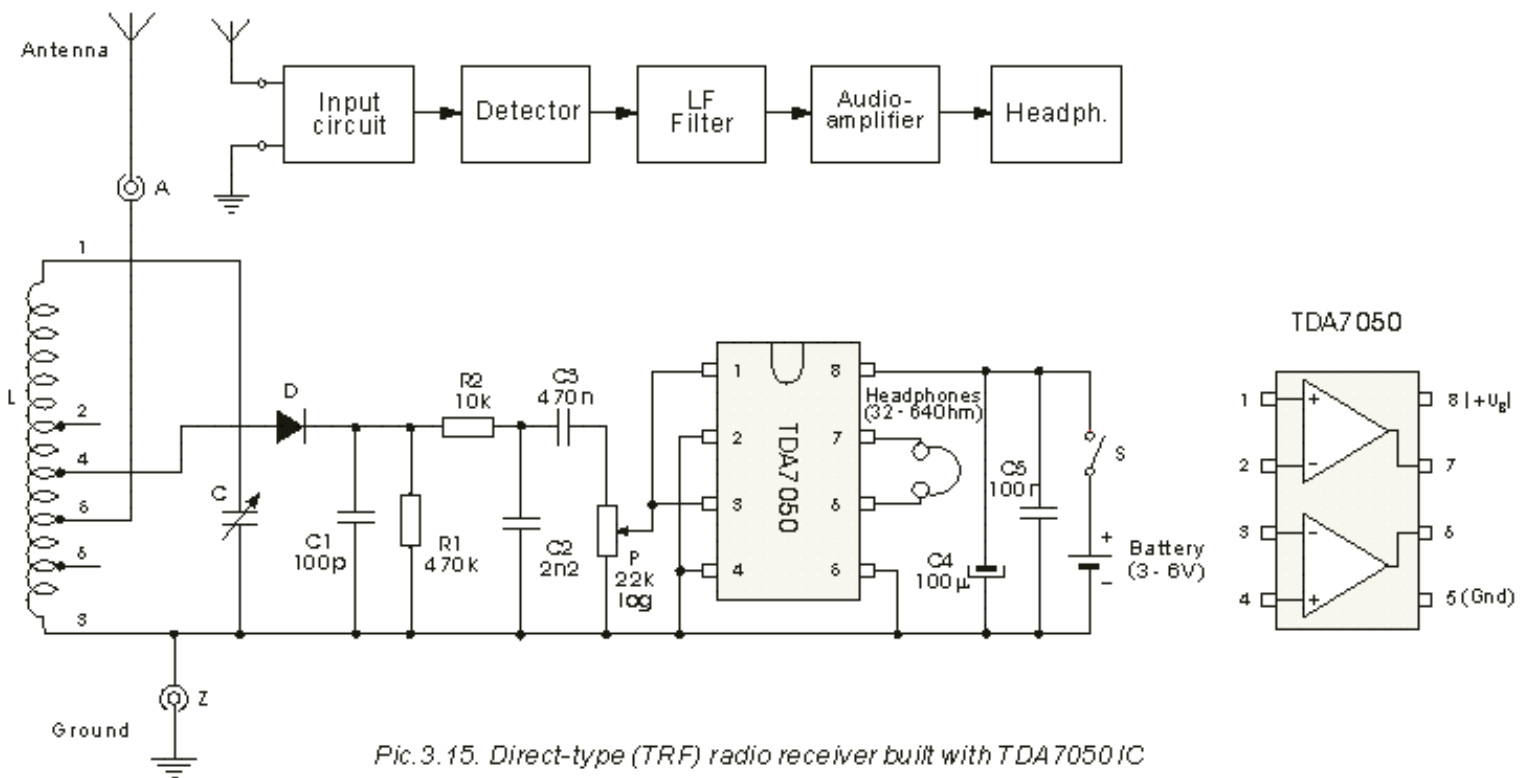

Pic. 3. 15. Direct-type (TRF) radio receiver built with TDA7050 IC

Let us finally add that the antenna can also be connected to point 1, over the coupling capacitor (C1 on Pic.3.1), and the detector on one of the coil legs, or you can connect both the antenna and the diode's anode on the same leg, to connect the anode to point 1, etc. You should try various combinations out, observing their influence on the reception. You should certainly re-tune the resonance of the oscillating circuit after every change, with the aid of the variable capacitor C.

The resistor R2 and capacitor C2 create an LF filter, whose role is to pass through at the next stage the LF signal being detected, preventing simultaneously the HF voltage do the same (this voltage originates from the AM signal carrier). This filter circuit affects the LF signal tone colour. If you don't like it, you should alter the capacitance C2 in order to change it.

PCB for this device is shown on Pic.3.17. The receiver can be put in a box just as on Pic.3.14. The only significant difference is that a 4.5 V battery pack must be used instead of 1.5 V battery, but there's plenty of room for it.

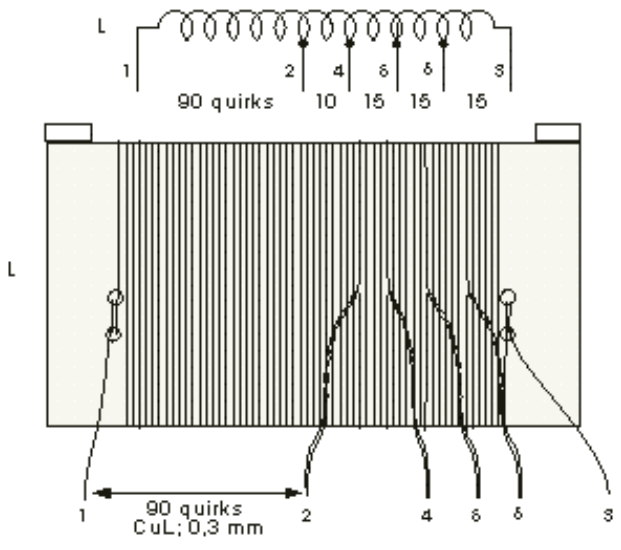

Pic. 3. 16. a-Multiple-leg coil for MW, for the receiver from pic. 3. 15

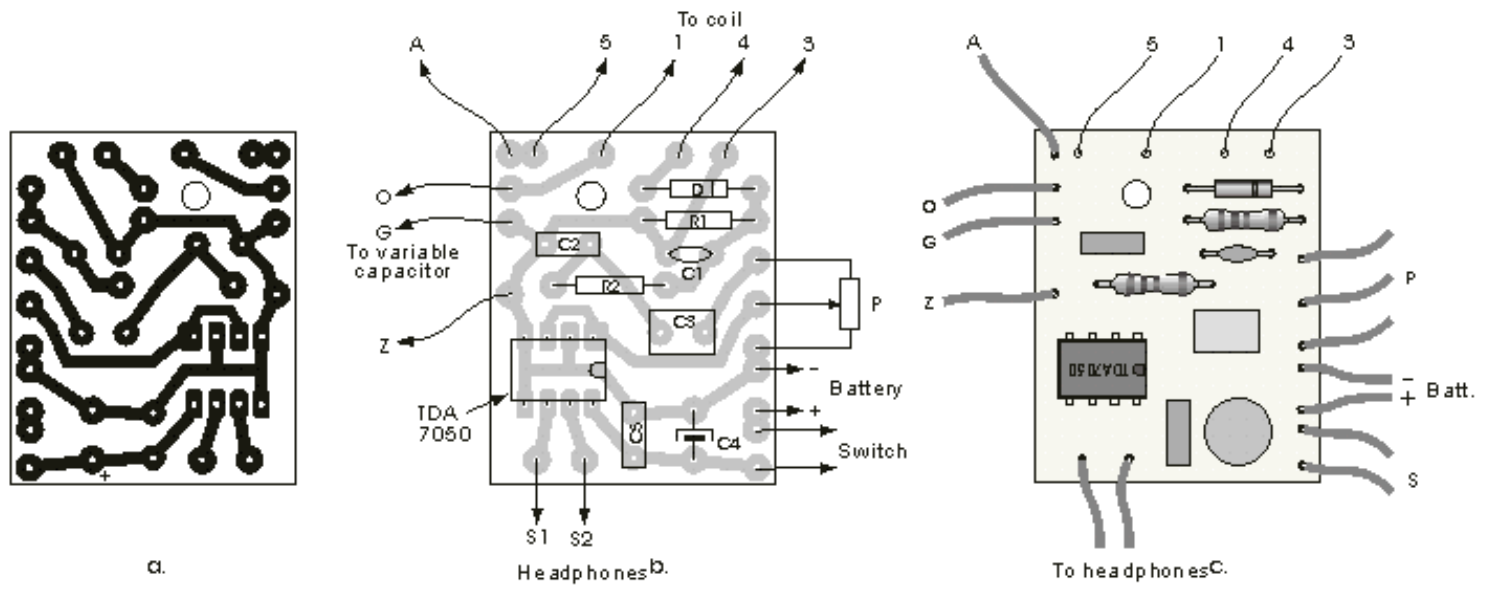

Pic. 3. 17. PCB for the receiver from pic. 3. 15: a-soldering side view, b-component side view, c-photo-view

3.4. Simple Radio Receiver with LM386 IC

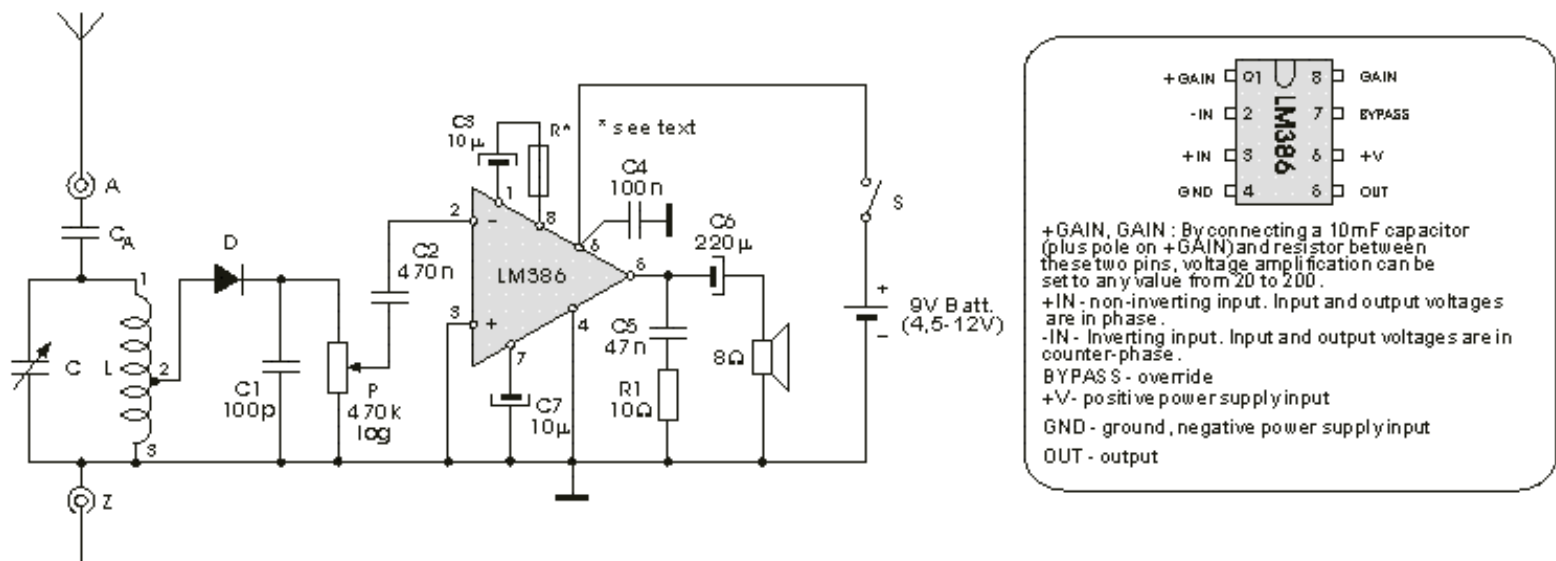

Pic. 3.18 a-Electronic diagram of the detector (TRF) radio receiver with audio amplifier built around the LM386 IC

Listening the programme over the headphones has its advantages, but the true radio receiver is certainly the one that with the loudspeaker. In this project the simplest such receiver is being described, consisting of input circuit, diode detector and audio amplifier with LM386 IC, that allows the loudspeaker reproduction to be performed.

The author has firstly met with the LM386 circuit over twenty years ago, and has ever since been using it very successfully in various devices. The fact that this IC has survived at the market for such a long time is a considerable proof of its quality, however, its most significant advantage remaining extremely low price. The readers can find more information on this circuit in book 4 of PE. Purchasing this IC, one must have in mind that it is being manufactured in several versions, marked as LM386, LM386N-1, LM386N-3 and LM386N-4, that differ themselves by the supply voltage values and the output power. In case the supply voltage being no greater than 12 V, any of these can be used in this receiver.

Electronic diagram of the direct radio receiver that has a LM386 IC in its LF stage is given on Pic.3.18. The resistor in the detection circuit is the log type 470 kOhms potentiometer. The LF voltage is being led over its moving end and the coupling capacitor C2 onto the inverting input (leg No.2) of the LM386. Other, non inverting input (leg No.3) is connected to the ground. The output is on the leg No.5. On this leg the load (i.e. 8 Ohm impedance loudspeaker) is being placed, connected over the C6 capacitor to the ground. With smaller battery power supply voltages a 4 Ohm impedance loudspeaker can also be used. If there's nothing in between the legs 1 and 8, the voltage amplification of the IC is $A_u=20$, in which case the capacitor C7 can be omitted. If, however, a 10 μF electrolytic capacitor is connected between legs 1 and 8 (+ end on leg 1) as shown on Pic.3.18, the amplification is $A_u=200$. Adding a resistor in line with the abovementioned capacitor, any amount of amplification between 20 and 200 can be achieved. This resistor is shown in dashed line on Pic.3.18 and is being marked with "*" sign.

The PCB and components layout for the receiver shown on Pic.3.18 are given on Pic.3.19. Miniature loudspeakers from the pocket-size radio receivers should be avoided, since their efficiency and sound quality are poor, especially in the low frequencies area. On Pic.3.19 a 1W loudspeaker is being shown, whose membrane is 8 cm in diameter. That isn't such a bad solution, but even better would be using the loudspeaker with greater power and membrane diameter (During the testing the 3 W , 8 Ohm loudspeaker has also been used, and the sound quality was much better than with the one that is shown on the picture). As you can see, the cables connecting the loudspeaker with the PCB are firmly twisted around each other. This is a must, especially for the cables being longer than a dozen centimetres. The same has to be done with cables that connect PCB with the battery and the main switch Z.

Significantly louder reception, with bandwidth being narrower in the area of the lower bound frequency, can be accomplished

with the coil that has smaller inductivity and the coupling capacitor CA with greater capacitance. For example, if you are interested in radio stations that emits the signal in the MW area from 750 kHz to 1700 kHz, you could use the coil that has been previously described, by using only its' part between the legs 1 and 2, as shown on Pic.3.20. For the antenna that is about 6 m long use the CA=33 pF, and the reception is going to get better. Try increasing the CA capacitance (47 pF, 100 pF, 200 pF), the reception is going to get louder and louder, but the reception bandwidth will be getting smaller and smaller, some stations will not be heard any more, others will start to "mix" etc. it is up to you to find an optimum that suits you best. If using very short antenna, you should omit CA, and connect the antenna directly to the oscillatory circuit (at pt. 1).

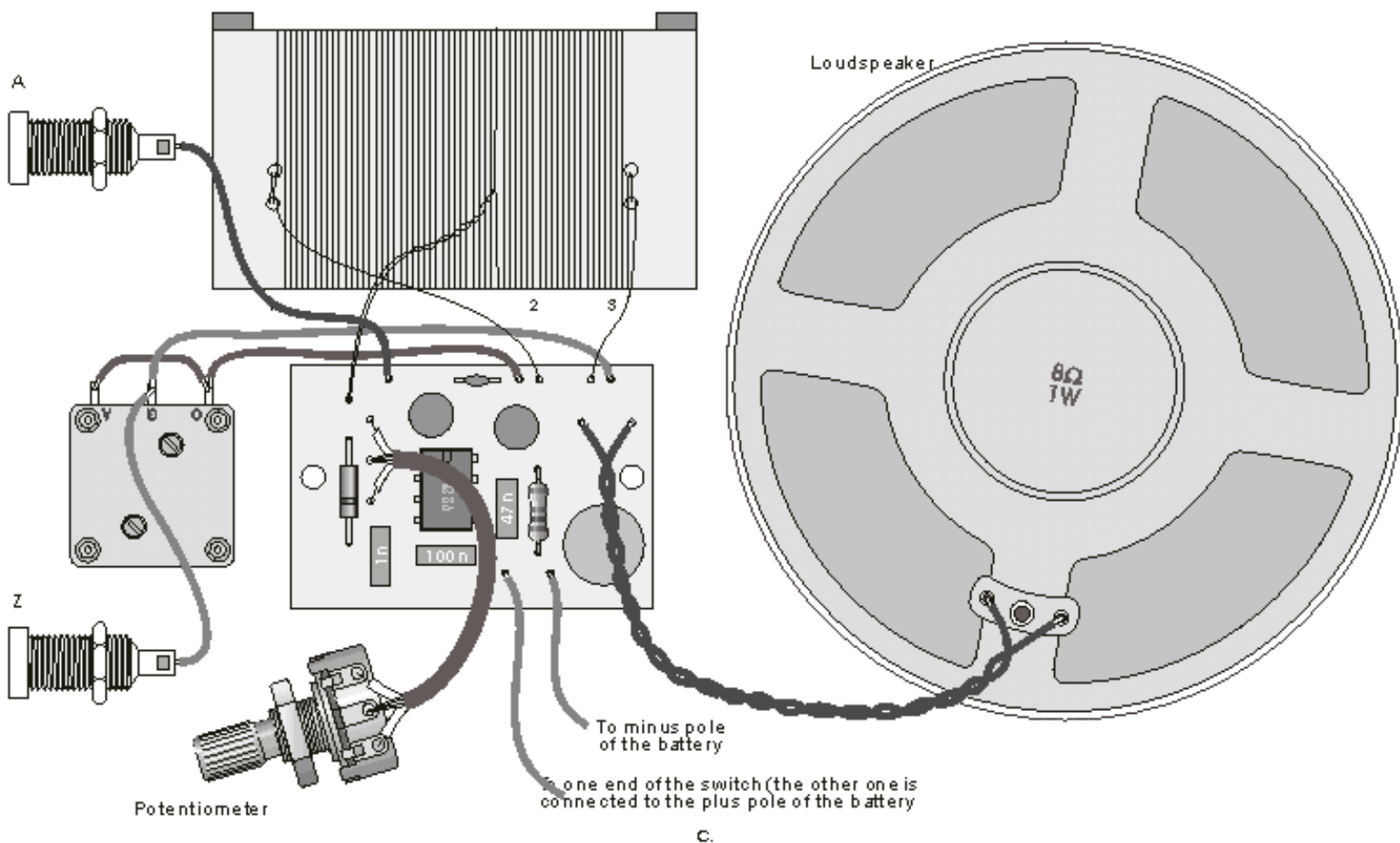
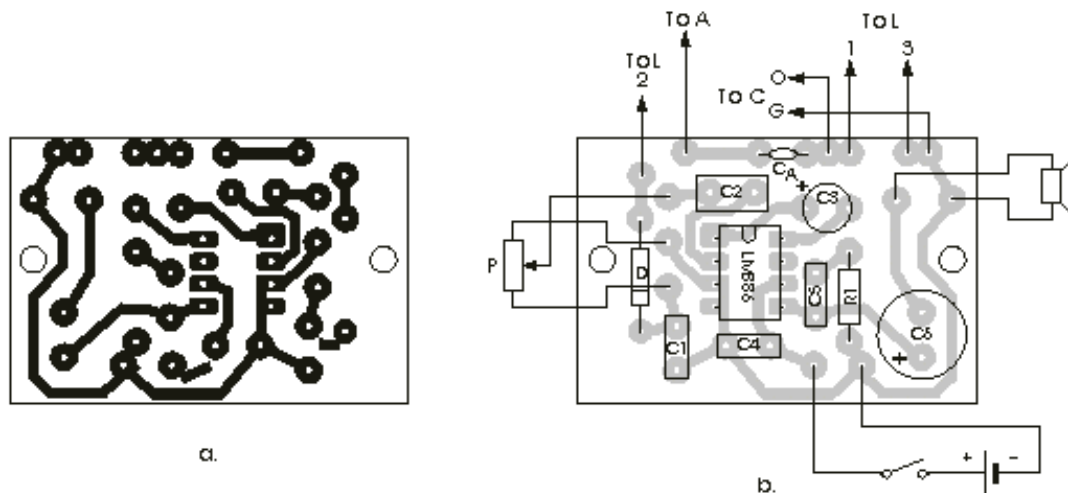

Pic. 3.19. Practical realization of radio receiver from pic. 3.18: a-PCB, b-component layout, c-connecting the board with other components

3.5. Radio Receiver with Increased Sensitivity Audio Amplifier

If you cannot obtain the signal reception that is loud enough with receiver from the previous project, the sensitivity of the LF

part of the device must be increased. The simplest way to manage this is adding a transistor pre-amplifier, as shown on pic.3.21. Please note that all the components except C1, C and L are located on the PCB, which allows you to use the input circuit from pics.3.15 and 3.20. The receiver is supplied from the 4.5 V battery but, if you intend to use an adaptor, the supply voltage can be bigger, its maximum value being from 12 V (for the LM386) till 18 V (for the LM386-4). The optimal value for R3 resistor (obtaining the greatest amplification, minimal distortion etc.) depends upon the kind of transistor that is being used. The easiest way to finding it is by experimenting, with a few MOhms' trimmer resistor, in the way it has already been described in chapter 3.2.

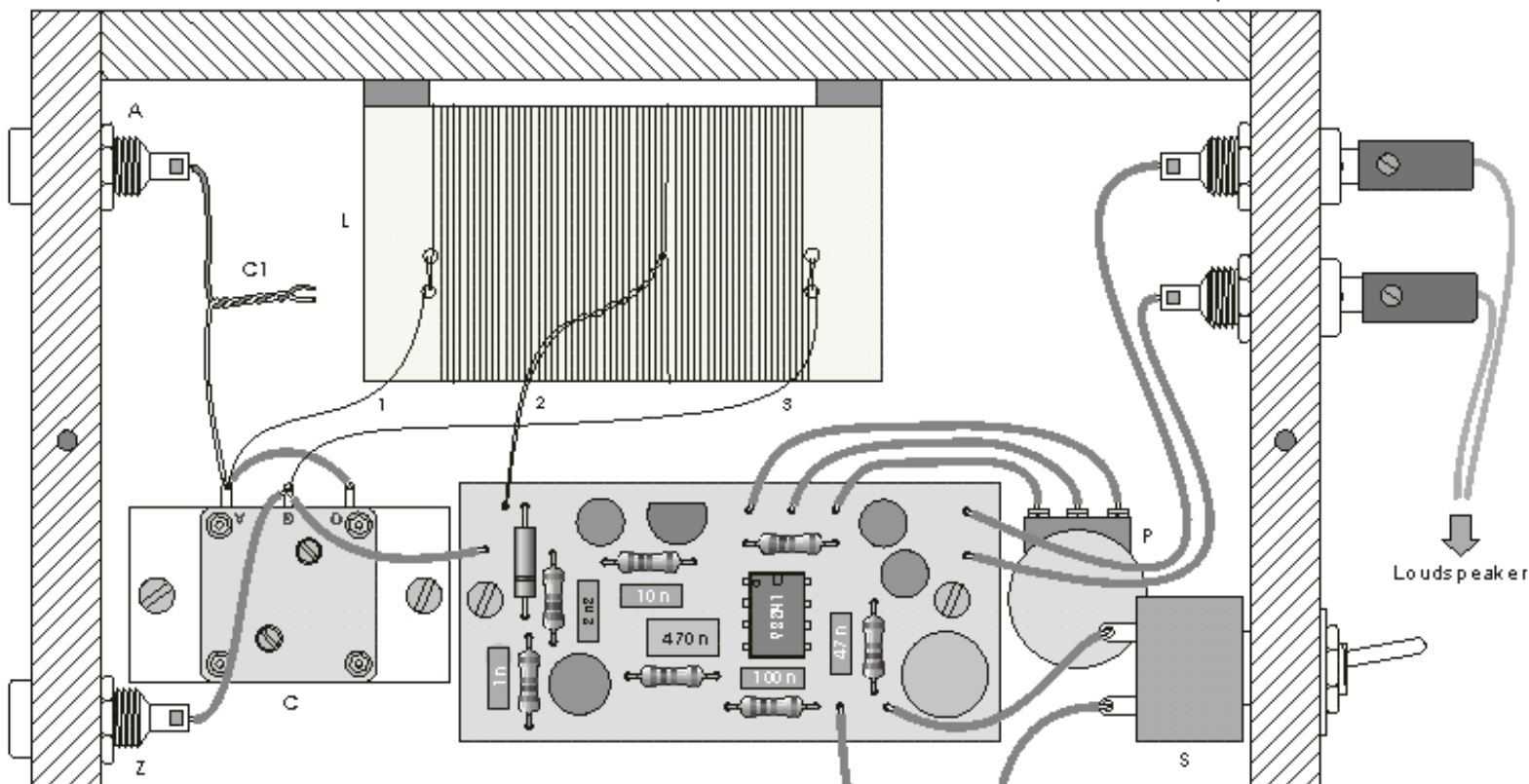
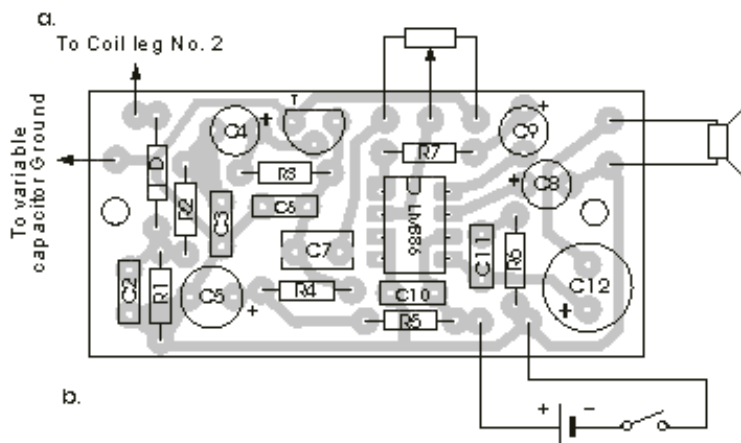
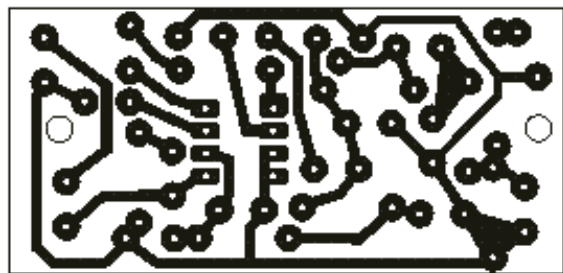
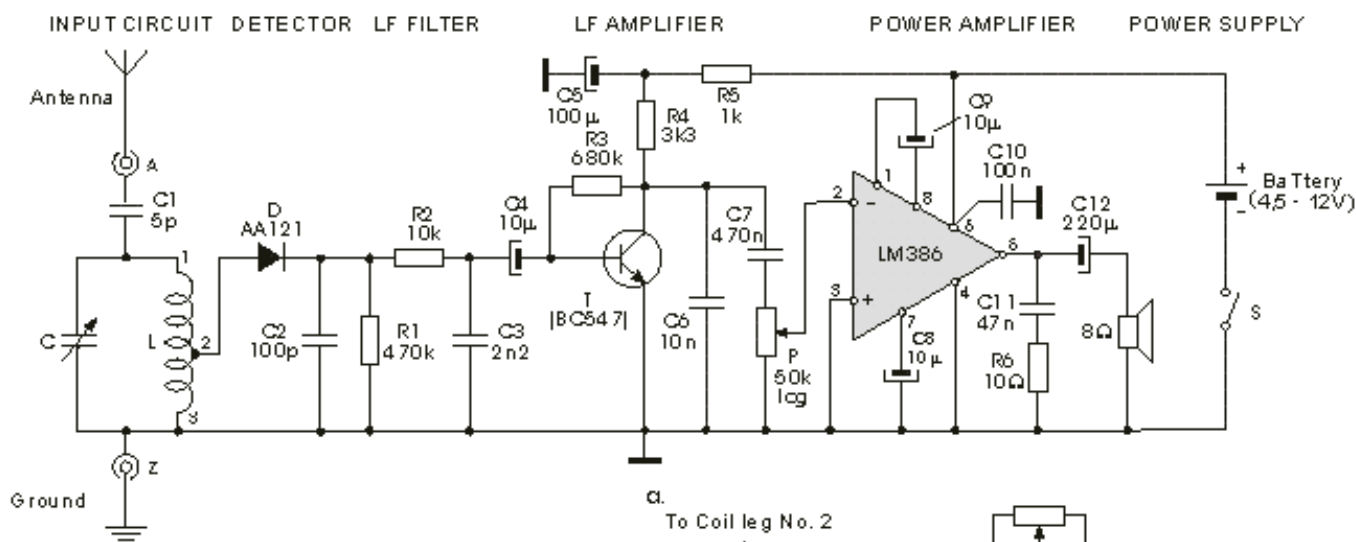

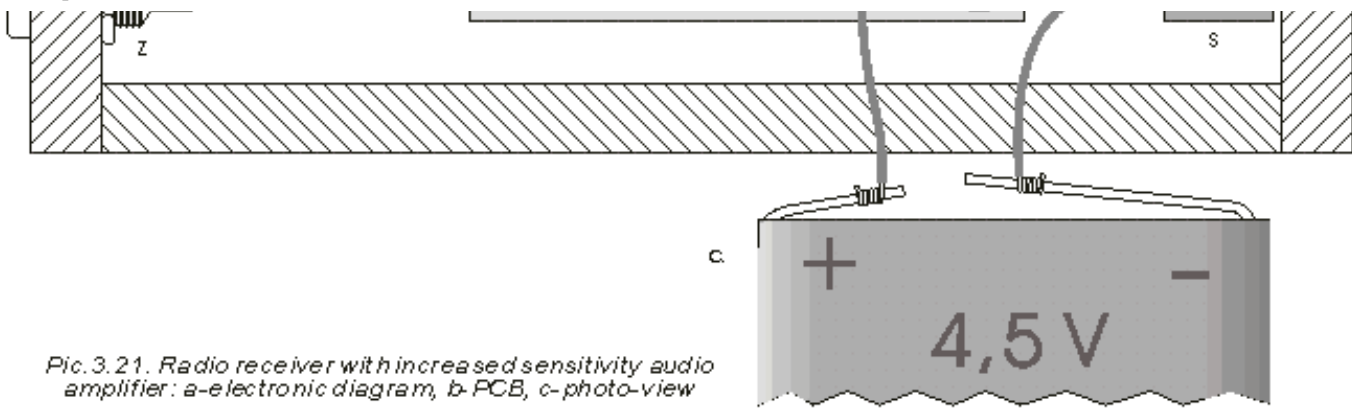

Fig. 3.21. Radio receiver with increased sensitivity audio amplifier: a-electronic diagram, b-PCB, c-photo-view

3.6. Universal Audio Amplifier

In majority of the receivers described so far, as well as in many those that will be described further, an audio amplifier is being used. This makes it useful to build an universal amplifier that would be used during testing of all receivers. That can be the circuit from pic.3.21 (from C4 inclusive to the right), but it can be something else, too, e.g. the one from the pic.3.22. Two IC's are used in it: operational amplifier TLO71 as the pre-amplifier, and LM386 as the power amplifier. The TLO741 is exactly the same as the more famous 741, the only difference laying in fact that TLO71 has the FET on its input, and 741 - the bipolar transistor. Since inverting input is being used in the operational amplifier, its voltage amplification is given by $A_u = R_P / R_1$, where R_P stands for the potentiometer resistance from the sliding contact to its left end. When the slider is at its rightmost position, it is then $R_P = 470 \text{ k}\Omega$, yielding $A_u = 470$, and when it's at its leftmost position the $R_P = 0$, therefore $A_u = 0$. As you can see, moving the slider changes the amplification from 0 to 470. That's what theory says, the practice is, of course, somewhat different. When capacitors are being connected between the input and ground, maximum amplification gets lower than 470 but is still more than enough for our needs.

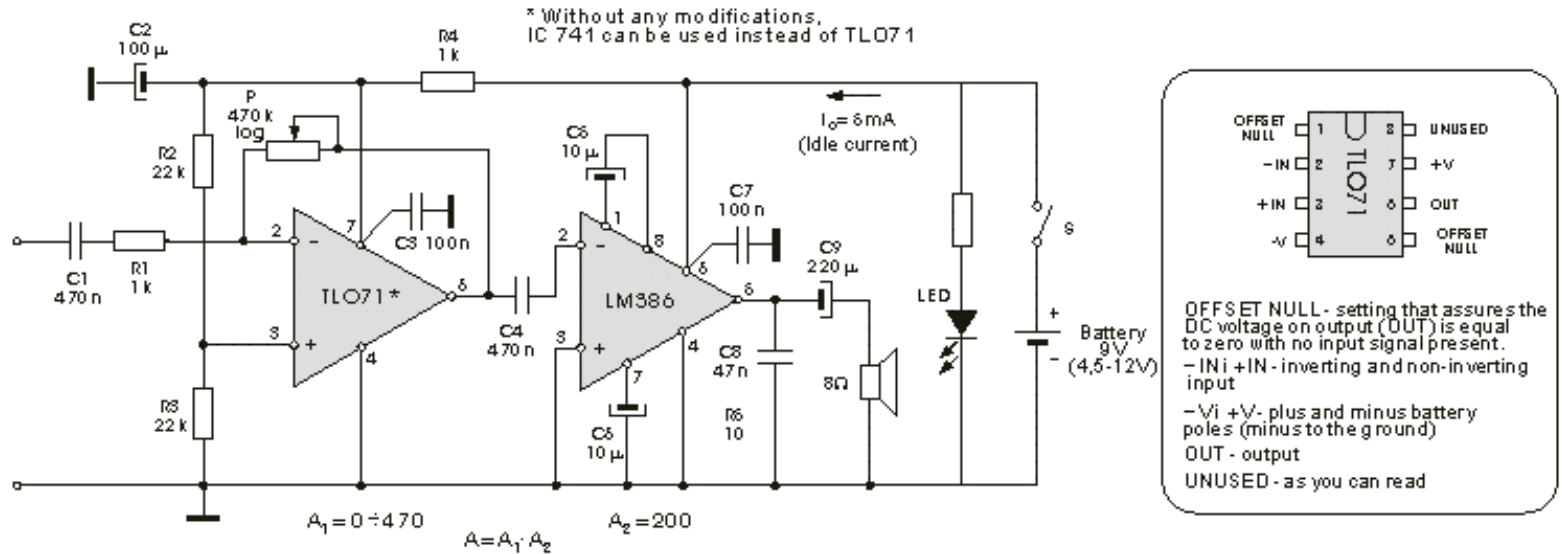

Fig. 3.22. Audio amplifier built with TLO71 and LM386

the plus battery pole with second instrument probe, and it will measure the idle current of the amplifier, which should be app. 5 mA. If this is OK, touch the pin No.2 of the LM386 with finger, and if everything is fine you will hear the 50 Hz hum from the loudspeaker. The power amplifier is OK. You can now solder C4. Touch the left end of the wire that is connected to the C1 with your finger, the hum should be heard again from the loudspeaker, its loudness depending upon the position of the slider of the potentiometer P. (If you don't possess an instrument, connect the battery on the wires "A" and "B" and do the touching described. If you hear the hum, the amplifier is OK).

If the Idle current is zero or is significantly bigger than 5 mA, something is wrong. If it's zero, check out whether you have connected your instrument properly and whether it is functioning. Remove the instrument and connect the battery directly to the wires A and B. Touch the pin No.2 of LM386 with your finger, if you hear the hum - your instrument is malfunctioning. However, if the instrument is OK, you should check the DC voltages. Set your multimeter to measure DC voltages, connect one probe (the one marked with the ground sign) to the amplifier ground (minus battery pole) and with second probe touch the plus battery pole first, and then pin No.6 of LM386. These two voltages should be equal to the battery (supply) voltage. Contact then pin No.7 of the TLO71. This voltage should be slightly smaller than the supply voltage. Voltages at pin No.5 of LM386 and No.7 of the TLO71 should be app. equal to the one half of the supply (battery) voltage.

Try to locate the malfunction based on your measurements. Check out if there are some discontinued copper lines on the print, or if two adjacent lines are connected (by themselves or by a small piece of tin that you dropped from the iron during soldering), whether all junctions are the way they should be, if you happened to mount some electrolytic capacitors or IC's upside-down, etc.

When you make sure that everything is fine, un-solder the potentiometer and the loudspeaker and put them on the front box panel. Also mount the plug and the switch, the LED (if used) etc. Tighten the plate with two small wood screws to the side pane, placing the LM386 on top (above the TLO71). Two distant-rings are to be mounted between the plate and the wood, making the distance between them a few (say, 5) mm. (These rings can be cut from some small plastic pipe). The screws are first to be put through the plate holes, then the rings and then screwed in the panel. After all this you can connect the loudspeaker, the switch, the battery, etc.

3.7. Receiver with the HF Amplifier

In HF amplifier the signal coming from the radio station is being amplified in its original form. In our case, this means that AM signal is led at input of the HF amplifier, and on its output the same shaped signal is obtained, only with bigger amplitude. This device got its name because it is used to amplify HF signals, although more precise term for it is the Selective Voltage Amplifier (that's how it is called in professional books).

Electrical diagram of a direct receiver consisting of HF amplifier, diode detector and LF (audio) amplifier is presented on Pic.3.24. This receiver does not have a selective input circuit. It would be better that way, the selectivity of the receiver would be better, but "technical reasons" made us not to include it: the double variable capacitor (like the one in the first issue of PE) i.e. the one consisting of two equal variable capacitors connected onto the common shaft, is very hard to find these days. The active element of the HF amplifier from Pic.3.24 is the transistor BC557 that operates in the common base junction. The station signal that is being amplified is led onto the emitter (i.e. between the emitter and ground), and the amplified signal is taken from the collector (i.e. between it and ground). Working principle is similar to the one of the input circuit explained with the Pic. 3.1-b. To refresh your memory: we have been considering an example where four signals of equal amplitudes but different frequencies, were present in the antenna: f_{s1} , f_{s2} , f_{s3} and f_{s4} . They were causing four different currents to flow through the LC oscillatory circuit: I_{s1} , I_{s2} , I_{s3} , and I_{s4} . All these currents were creating some voltage on the ends of the LC circuit, but the one caused by the current I_{s2} was significantly (about 20 times) bigger, due to the oscillatory circuit being set to its frequency. The parallel oscillatory circuit that is on Pic.3.24 as the collectoris exactly the same as the the one on pic.3.1.

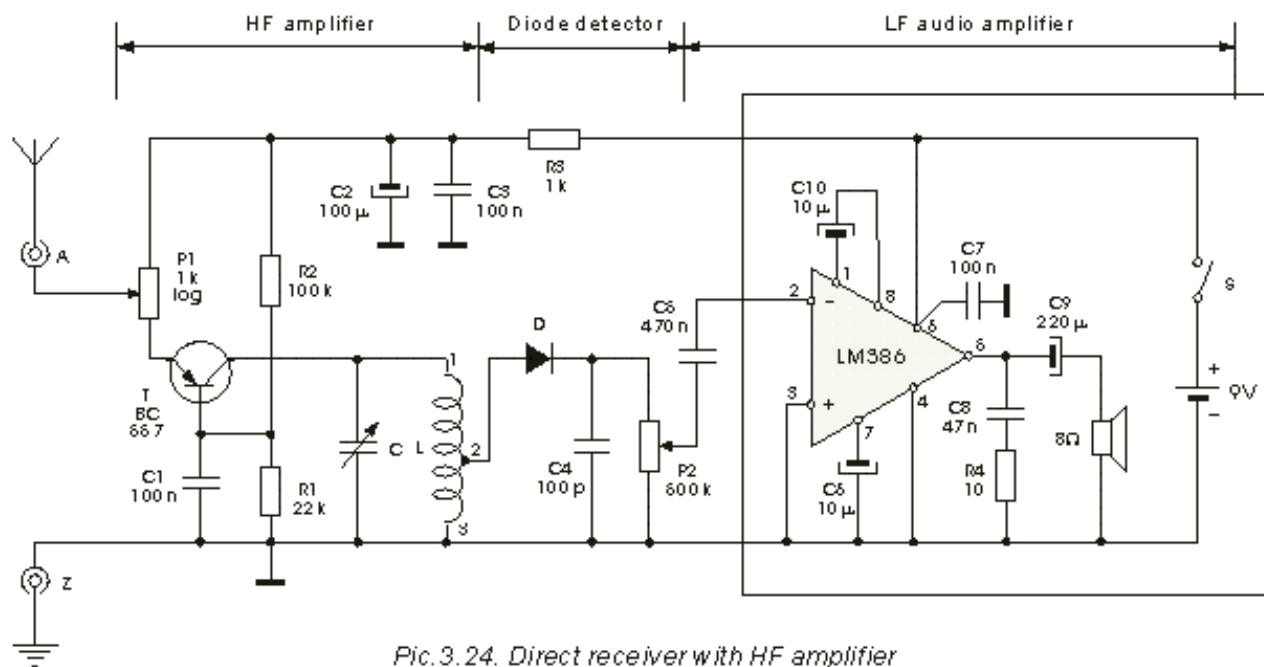

Pic.3.24. Direct receiver with HF amplifier

It also has the same role, therefore HF amplifier from pic.3.24 having the same selectivity as the input circuit in all the receivers described so far, with addition of extra amplification. This is being accomplished in the following manner: under the simultaneous load of 4 voltages that are coming to emitter from the antenna, their frequencies being f_{s1} , f_{s2} , f_{s3} and f_{s4} , four currents flow simultaneously through the transistor. They share the same circuit: from positive battery pole, through P1, then transistor (in direction emitter-collector), over the LC circuit to the minus battery pole. All of them therefore flow simultaneously through the LC circuit as well. The resonance frequency of this circuit is set (by C) to be equal to the frequency of one of the currents and it acts upon it as a huge resistor (200 kOhms, as on pic.3.2-b). According to Ohm's Law, this current creates voltage on the oscillatory circuit. For other 3 currents the circuit acts as a resistor with much smaller resistance (less than 20 kOhms, as on pic.3.2-b) and they create much smaller voltage in the circuitry (10x smaller, as in our example). The important difference in operation of circuits from pics. 3.1 and 3.24 is that all currents are much smaller in the latter case (because of the amplifying effect of transistor), therefore the voltages on the LC circuit being much bigger.

* With P1 potentiometer the signal amplitude from antenna to the input of HF amplifier is regulated. If, on your device, you find the slider for all stations to be in rightmost position, put a resistor instead of potentiometer, and connect the antenna with emitter.

* As with all input circuits, when connecting the capacitor C care should be taken to connect the rotor to the ground (G-point on pic.3.7-a).

* The R3 resistor comprises with C2 and C3 capacitors the LF filter which prevents the feedback (that would lead to unstable operation) between the LF circuitry and HF amplifier. If the feedback still occurs, the R3 resistance should be increased.

* In LF part of the receiver the audio amplifier with LM386 IC is used. That is by no means necessary, any audio receiver will do.

* There is also a better variation of HF amplifier, with increased selectivity. Its electronic diagram is shown on pic.3.29-b.

3.8. The Audion - Direct Receiver with Drain Detector

During the experiments with this receiver, the Author had decided to name this chapter "The BEST Direct (TRF) Receiver", which he gave up on later, having in mind the old Latin saying: DE GUSTIBUS NON DISPUTANDUM EST (Tastes should not be discussed). It is, however, very hard to make something better with so little components. Anyway, the Author leaves to the readers of this chapter to name their own Best Receiver candidates, picking one of these described in this book, having in mind their own criteria for concepts of the beautiful, simple, cheap and useful. You can mail your voices to me on the address: ETŠ "Nikola Tesla" (Praktična ELEKTRONIKA), Narodnog Fronta 31, Beograd, or by E-mail: tesla@drenik.net, Subject: Pe9.

On Pic.3.25 you can see the electrical diagram of this, however, anyway, nevertheless... Device. The signal of the tuned-in station is lead to the Gate of the BF256 transistor. Please notify that the signal is being taken from the upper end of the coil, and not from its leg, as it has been in previous projects. This is possible due to big input resistance of the FET (bigger than MegaOhm), compared to the one of the bipolar transistor (couple of kiloOhms). Why is this so important? Pic.3.26 shows the voltage - frequency curve of the parallel oscillatory circuit that is made of the coil L and capacitor C, while being tuned to the station whose frequency is f_{s2} . In case the circuit is not loaded (the next stage of the device is not connected to it), this curve is shown in solid line and, as previously explained, the voltage (measured at the ends of the osc. circuit) of the station with carrier frequency f_{s2} is significantly bigger than the voltages of the stations with frequencies f_{s1} and f_{s3} , although all of them have the same size in the antenna. However, when the next stage, containing the bipolar transistor as, for example, the one on the Pic.3.12, is connected, its small input resistance is damping the circuit and the bandpass curve has

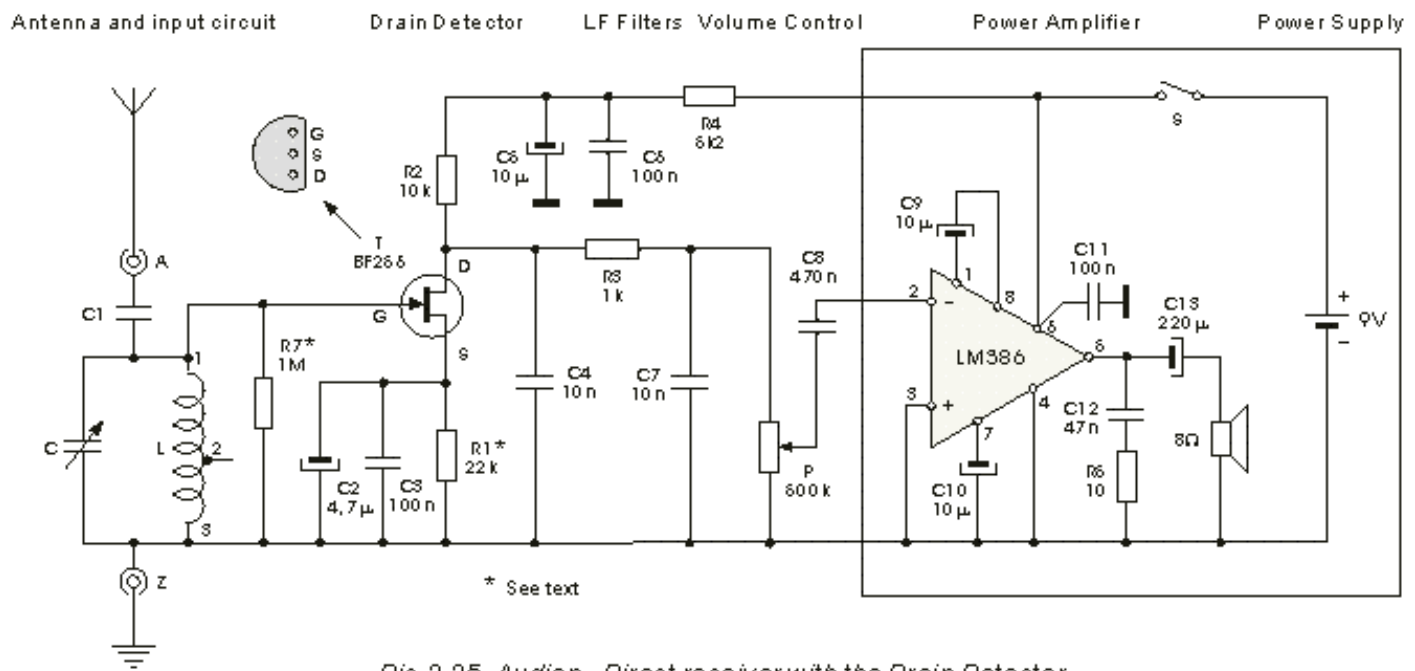

Fig. 3.25. Audion-Direct receiver with the Drain Detector

he shape shown with the dashed line, marked as Q2. When the FET is connected to the oscillatory circuit (as on Pic.3.25) there is practically no damping, and the bandpass curve remains as shown in solid line. This is, clearly, much better, since all the other station voltages are more suppressed (reduced), comparing to the voltage of the tuned station. Considering the curve marked as Q3, we will be discussing it more in context with the Pic.3.29-a.

It has been earlier noticed that the most important characteristic of a parallel oscillatory circuit being used in a receiver is its resonance frequency

$$f_r = \frac{1}{2\pi\sqrt{LC}}$$

Its second most important feature is the Goodness Factor of the receiver, which is most often being marked with the letter Q, and is therefore also known as the Q-Factor. A loaded circuit has smaller Q-factor than the non-loaded one, as shown on Pic.3.26, consequently being $Q_1 > Q_2$. For example, the goodness factor of the circuit from Pic.3.6 is $Q=95$. Since it is not loaded, the oscillatory circuit on Pic.3.25 has smaller (narrower) bandpass and therefore better selectivity. Additionally, since the whole signal from the circuit is led in the next stage (instead partly, when getting the signal from the coil's leg), the receiver has got bigger sensitivity (it's capable of receiving weaker signals).

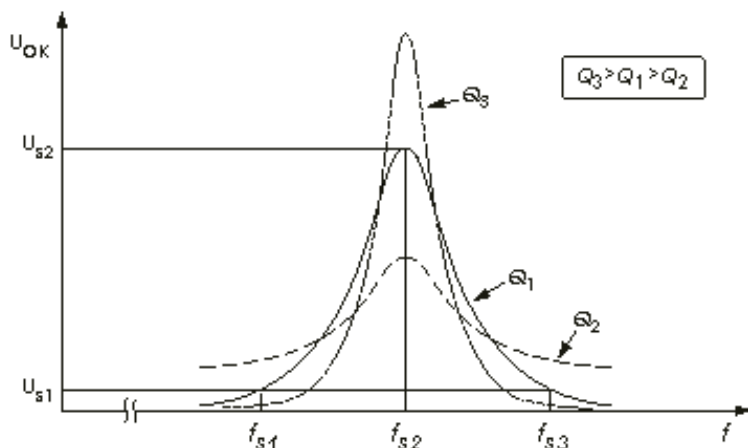

Fig. 3.27. Bandpass curves of a parallel LC circuit

The FET, together with R1, R2, C2, C3 and C4 forms the so-called Drain Detector (its analogous circuit with bipolar

transistors is the Collector Detector, and with the electronic tubes - the Anode Detector. The popular name for the anode detector was - the Audion). The LF signal being detected is received on the drain (D). It has the same shape as the LF signal obtained on the output of the diode detector, but is significantly bigger than it, since the drain detector also amplifies the signal. The LF signal is then led on the volume regulation potentiometer, over the filter that is used to suppress the remains of the HF signal carrier (R3 and C7). After that it goes to the audio - receiver.

* The R7 resistor can be omitted. If you do that you should switch off the battery (over the switch S) every time you are removing the coil from the circuitry (during experiments). If you fail to do so, the oscillation in the circuitry will occur, and loud hum will be heard from the loudspeaker.

* Since FETs have very different characteristics compared to each other, it might be necessary to change the value of R1 resistor. The simplest way to do it is to place a 50 kOhm variable resistor instead, tune the receiver to some radio station and then achieve the best possible reception by moving the slider. The resistor is then removed from the circuit, its resistance measured, and the (fixed value) resistor of similar resistivity soldered in the circuit. The same goes for R2.

* The filter (R3 and C7) used to suppress the remains of the signal carrier affects the colour of the tone of the LF signal. If you wish more bass tones you should increase the C7 capacitance. Similarly, if you wish more high pitch tones, C7 should then be decreased.

* The receiver will not start operating the very same moment the switch S is engaged. That is due to a fact that the FET doesn't work under small supply voltages. Its supply voltage is the one on the C5 capacitor and the detector won't work until C5 doesn't fill. This is being achieved through R4. Since this resistance is quite big and so is the capacitance of C5, the filling time is rather long. If, however, you just need the receiver that will have a "late start", you should be increasing the capacitance and the resistance until reaching the desired delay time.

* This receiver works well also with the ferrite antenna. On Pic.3.27-a you can see the symbol for it, and on Pic.3.27-b its shape and dimensions are given. The simplest thing to do is using the antenna from an old pocket radio, probably the same one you took the variable capacitor from. During the dismount, you should by no means cut the coil ends or shorten them later. Instead, you should carefully un-solder and unhook them from the PCB (the coil is made of the "litz wire", consisting of a dozen very thin lacquer - isolated copper wires, wrapped together with the thread. If you cut this cable, you will find very hard to re-solder it, since it is difficult to remove the lacquer from all the wires without damaging (some of) them). Such an antenna, as seen on picture, has four ends. We shall be using the coil L, therefore only significant ends for us are those marked as 1 and 2. The end No.1 is easy to identify, it is the single one, which is not the case with the end No.2. To detect it in the group of three you will need an ohm-meter of some other conductivity tester, which you should connect to the end No.1, and then search for No.2 by touching those 3 remaining ends.

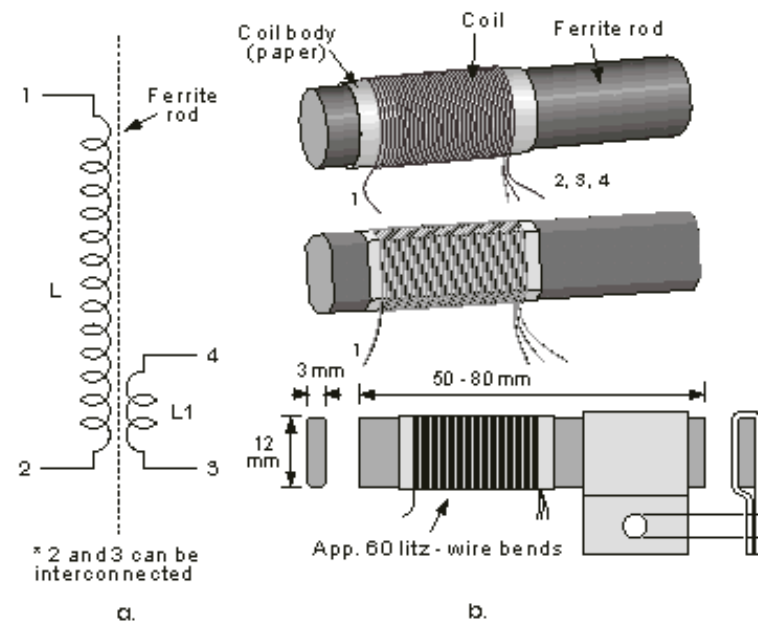

Pic. 3.27. The Ferrite Antenna: a - symbol, b- appearance

In the lower right corner of Pic.3.27-b you can see means of attachment of such an antenna to the PCB. The envelope being shown is made of carton. It is wrapped around the ferrite core, and then glued to it. The screw is mounted through the hole and the antenna is then attached to the PCB. Instead of screw and nut, the antenna can also be glued onto the board. If the ferrite rod is longer than 6 cm, the envelopes should be mounted on both rod ends.

* C6 is the block-type capacitor that (together with R4) prevents the receiver from working in an unstable regime. If such a thing occurs, its capacitance should be increased. If that doesn't help either, or if the detector is working improperly, you should try increasing R1 and R4.

* With this receiver the reception of the SW band stations can also be achieved. All that is to be done is making a new coil. For these purposes we utilized a piece of carton cylinder already used for building our coil L (described in previous projects). On it, we banded tightly 6 bends of 0.6 mm copper wire. The wire diameter isn't critical, practically any can be used. This coil is shown on Pic.3.28-a, together with attachment plates. This coil should replace the coil L, as seen on Pic.3.25. With 6 m long antenna and the antenna capacitor C1=12 pF, the reception bandwidth should be app. from $f_d=7$ MHz till $f_g=10$ MHz. This can be changed by changing the number of bends on the coil and /or C1 capacitance. In such a way you can "take a peek" what's happening in the civil area, what are the radio - amateurs doing, some professional links etc. You can even make a multiple - legged coil, such as on Pic.3.28-b (number of bends isn't critical, it may be useful trying out some other values, too), and to be able to choose SW1, SW2, SW3 with a selector switch. Please do have in mind that the reception quality of the SW stations isn't the same during the day. It is good in the afternoon hours, during the night and in the morning, the weakest reception quality is around noon. But, that isn't all. It also depends on the season, solar activity etc. Anyway, you should see it for yourself.

There's also a possibility of receiving professional stations working on considerably higher frequencies. The coil, which is then also an antenna, is given on Pic.3.28-c. It is made of stronger, thicker wire or a metal band, being circularly shaped and then attached to the wooden plate with two screws. With same screws cables connecting the antenna with the variable capacitor C are affixed. The antenna diameter varies from couple of cm till few dozens cm, the real value being found by experiments. It is a directive antenna, which means that the amount of voltage being induced in it depends also upon the direction where the waves are coming from. This gives you the opportunity of achieving the optimum reception of the desired station and simultaneous suppression of others by rotating the antenna. Similar antennas are used in radio - location (searching for whereabouts of an unknown radio transmitter).

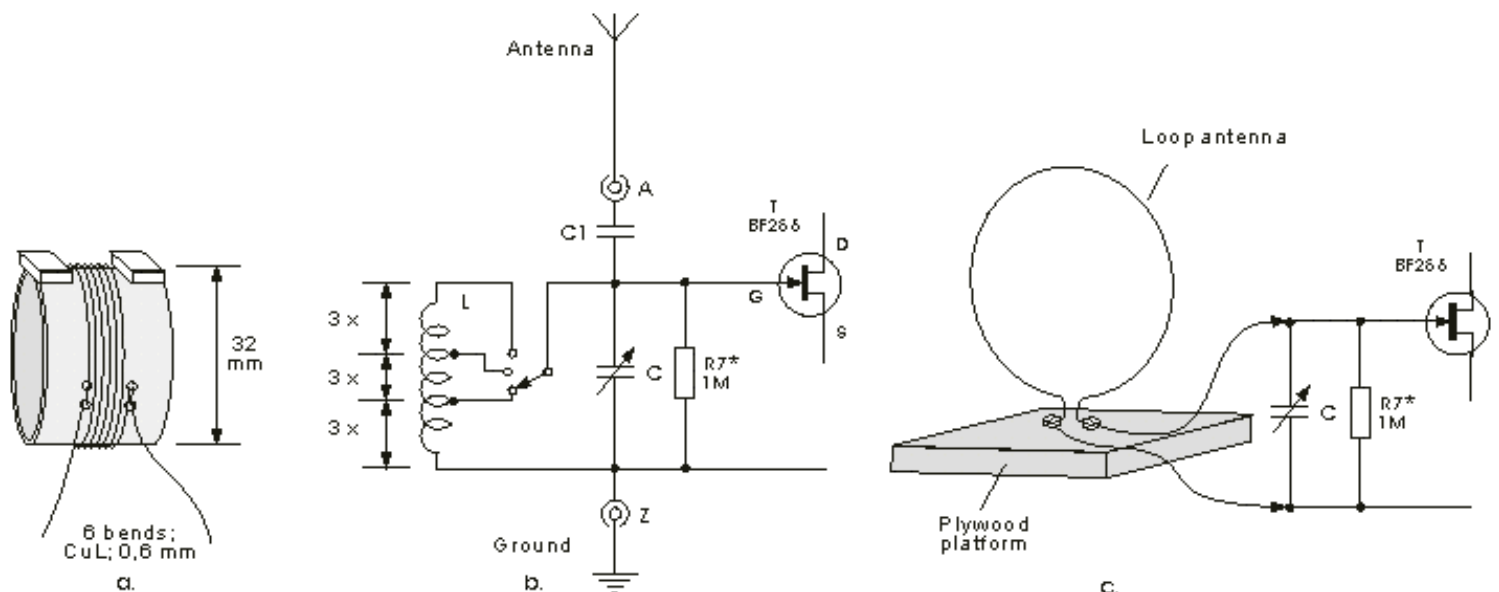

Pic.3.28 a - SW band coil; b - Input circuit with 3 SW bands; c - Coil for VHF & UHF bands

3.9-a Reaction - type Receiver

In the previous project, in the context of Pic.3.26, we have seen how important it is for an oscillatory circuit of the receiver to have as big Q- factor as possible. The bigger it is, the receiver gets more selective, i.e. capable to separate the signal of the station the oscillatory circuit is tuned at from the multitude of signals in the reception antenna, at the same time suppressing other signals. There is yet another important thing to be emphasized: the voltage in the oscillatory circuit is Q times bigger than the voltage that is being led to it from the antenna. If $Q=95$ and the voltage in the antenna is, say, 1 mV, the voltage exiting the circuit is then 95 mV. It is then clear that the Q- factor should be as big as possible. Some improvements can be made by using the silver - coated wire instead of the plain copper one, of using ceramic material for the coil body instead of carton etc. These improvements, however, are not significant. The solution for this was, eventually, found: It was the process known as the "regeneration", many scientists had been working on it simultaneously, A. Meissner being one of the more important ones. The complete process was patented in 1913 by the American radio - pioneer Edwin H. Armstrong, two months before his 23rd. Birthday. He discovered that the Q- factor could be extremely increased (even by couple of tens of times), if the signal from the inlet circuit would be amplified with the triode and then the small part of this amplified voltage adequately returned into the inlet circuit. The radio station signal could therefore be amplified to much greater extent, and the reception of very far stations became possible, the thing that wasn't even thought of, until then. From an average listener's point of view, the main mishap of this regenerative, or, here better known as reactive, receiver was the fact that optimal tuning required somewhat more skill and basic knowledge of the working principles. Much easier tuning was that of the superheterodyne receiver (invented also by Armstrong), which was reduced to turning only one reel, and it contributed, to a great extent, to its final victory. The battle between the two concepts lasted for almost half a century, but the reactive receiver did not retreat itself completely. Even nowadays an electrical diagram of some younger and more modern brother, or rather a grand-grandson of once famous reactive receiver, appears in some popular electronics magazine. One such diagram, where the triode is replaced by a MOSFET, is given on Pic.3.29-a. Radio engineering enthusiasts know that, as soon as the signal from the input circuit is led on the gate (G1) and that the source (S) isn't connected to the ground but to the coil leg (point No.3), they have a diagram of the Hartley's oscillator in front of them and that connecting the source to the leg No.3, the so-called positive feedback (positive reaction) is achieved. But, the abovementioned labourers also know that the oscillator shall oscillate only if the leg No.3 is made on the right spot, and the P1, TP1 and TP2 variable resistors are set on the right values. Let us imagine that everything is OK: the coil leg is right where it should be, the slider of the variable resistor P1 is in the middle of the range, and trimmers TP1 and TP2 are set in such a manner that the oscillator is really oscillating. It behaves then as the generator, that creates the sinusoidally - shaped AC voltage, whose amplitude is a couple of volts. Theoretically speaking, the Q- factor is now infinitely big . All this shall produce a very strong whistling sound in the loudspeaker. The slider of P1 should now be carefully moved downwards. The transistor amplification is hereby reduced and the oscillating stops. The Q-factor is being reduced too, it is no longer infinite but is still very big. The receiver is now tuned on the desired station. If the station signal is weak, everything should be OK and the programme should be heard. The reception can then be made better, by carefully operating with P1's slider. If the whistling emerges again, the slider should be moved backwards until it stops. If we come upon some stronger station the whistling will start immediately, in which case the slider P2 should be carefully moved downwards until it stops and the station programme is heard, loud and clear. As one may notice, every time this receiver is being attuned to optimal receipt the whistling is being heard for a short while. This is why it has been named "The Whistler", here in Yugoslavia .

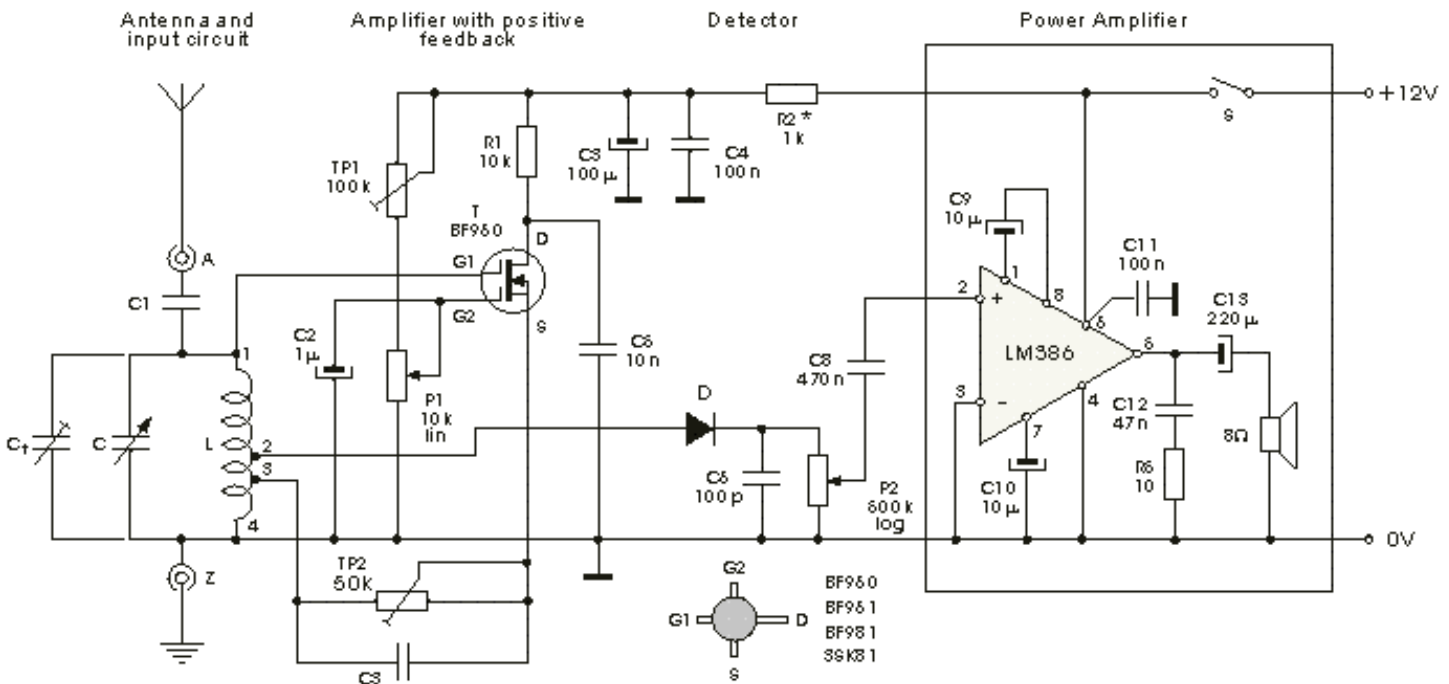

Pic. 3.29-a. Reactive Receiver with double-gate MOSFET.

The amount of the reaction (feedback, regeneration) is controlled with P1 potentiometer, which sets the magnitude of DC voltage on the gate G2 of the MOSFET, changing therewith the amount of its amplification. The range of this control is being determined with TP1 trimmer, G2 is connected to the AC signal's ground over C2 simultaneously eliminating the noise coming from the potentiometer, and the FET is de-coupled from the supply line (and therefore all other stages of the device by the LF filter made of C3, C4 and R2.

The receiver is being tuned as follows: Put the slider of P2 in mid position and later, after tuning, you can set the volume as you wish. Set the P2 at minimum resistance (slider full down), and P2 on maximum (slider full right), connect the antenna and close the switch S. Start moving the slider P1 upwards, the reaction gets stronger and stronger, and you can hear the typical hiss or some radio programme from the loudspeaker. Move the variable capacitor C and tune the receiver to various stations. If the whistling starts, put the slider P1 back down.

Set the capacitor is minimum capacitance position (see Pic.3.7), put the slider P1 fully upwards and start carefully increasing the resistance TP2 until the whistling stops. Measure the TP2 and insert in the device the ordinary resistor of similar resistance. The TP1 trimmer should be set in such a way to have as big resistance as possible, keeping at the same time the reaction effective throughout the entire reception bandwidth of the receiver.

* During every station change (with C), a maximum amount of reaction should be set (with P1). Move the slider upwards until the oscillating occurs, then put it back down a little.

* While receiving very strong signal (local transmitter), an overload can occur. If that happens, you should insert a 1 MOhm potentiometer between the antenna (A) and the upper end of C1 capacitor; it should be connected as the rheostat (like TP1 and TP2), then you can set the optimum reception with slider.

* SW - band stations can also be received with this device, with a different coil. In this case it would be very useful to add a trimmer capacitor in parallel to the variable capacitor, being marked as Ct on Pic.3.29-a. With it the so-called "range yielding" can be done (the initial, approximate setting is done with C, and fine tuning between closely placed stations with Ct). It should be mounted on the front panel, as close to C as possible. Another type of capacitor can be used as Ct, see more about it in the Appendix. The SSB (Single Side Band) technique transmissions are also being placed in the SW band area. These signals cannot be received with the earlier described receivers, but they can with this one. In that case the slider P1 should be moved a bit more upwards, so that oscillating can occur. The reception becomes clear, before that it was unrecognizable.

* If the local radio station still corrupts the reception of other stations, you should insert the circuit that will suppress its signal. You can read more about it also in the Appendix.

3.9-b Direct SW Receiver for AM, AM-SSB & CW Signals

SSB stands for Single Side Band, which signifies the amplitude - modulated signal which gets its signal carrier and one sideband suppressed in the transmitter. Carrier suppressing gives huge savings in transmission power (the power necessary to accomplish the desired reach of the signal is significantly smaller than in the conventional - type transmitters), and cancellation of one sideband makes the signal have its spectrum two times narrower, allowing twice as many transmitters as usual to be placed into the same bandwidth.

CW is for Continuous Wave, which determines the radio link where the Morse Code is being transmitted by cutting the oscillator work in the transmitter.

SSB and CW signals are impossible to accomplish with the receivers that use the ordinary diode - type detector (earlier described AM receivers). The receipt can be done only by bringing another signal into the detector, the HF signal from the oscillator, known as the BFO (Beat Frequency Oscillator). Simpler solutions, however, do exist. These are the reaction - type receivers, i.e. receivers with positive feedback.

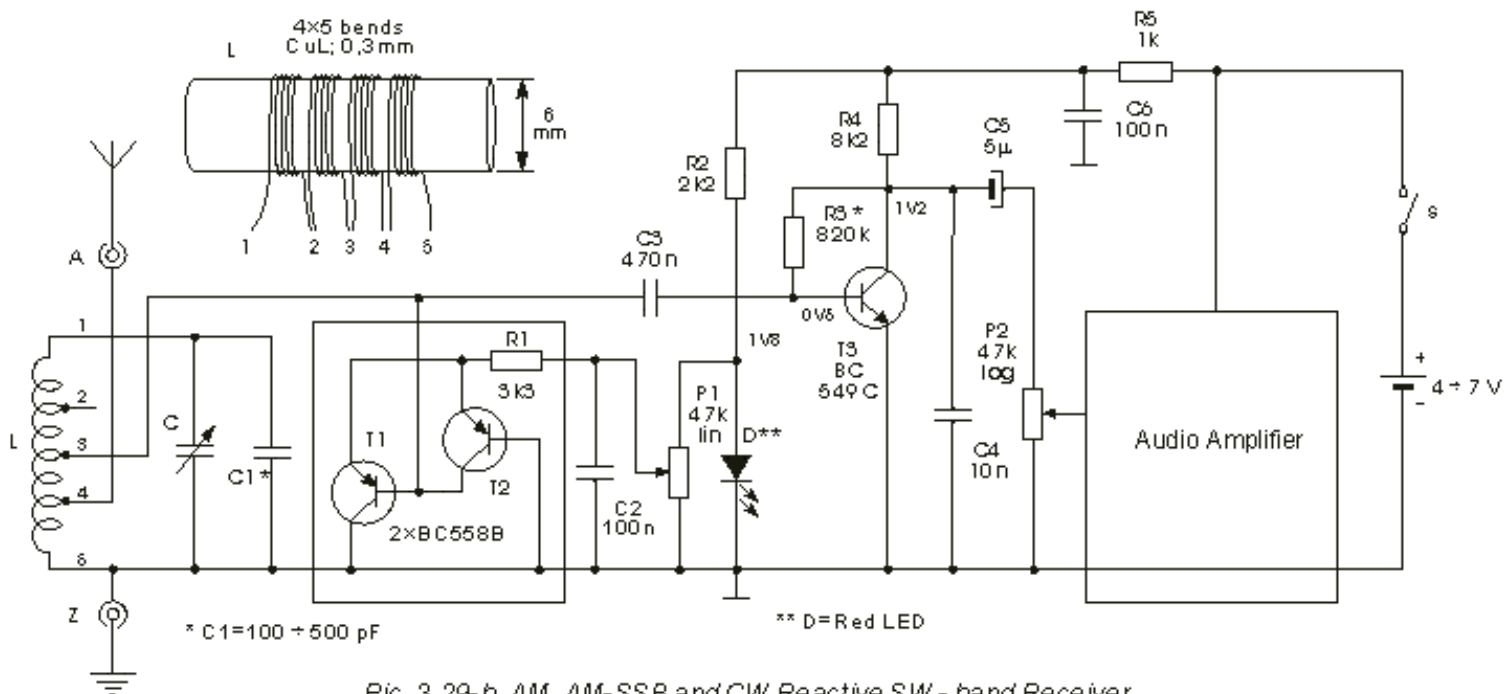

Fig. 3.29-b. AM, AM-SSB and CW Reactive SW - band Receiver

You have been able to see one of them in the previous project (3.29-a), and here we'll take a look at another one, which works so nice that we were sometimes having the impression it beats up much more sophisticated, modern superheterodyne receivers. Its electrical diagram is shown on Pic.3.29-b.

The coil L and capacitors C and C1 form a parallel oscillatory circuit whose role is to separate and amplify the signal of the tuned station, and to suppress all others. It doesn't entirely succeed in that, however. The reason for this is small Q- factor of the oscillatory circuit, being such because of big energy losses in the circuitry. There are many kinds (reasons) of these losses, but we can imagine in first approximation that there's a resistor R_G in the circuit which represents these losses, its resistance being such that the oscillating current transforms itself into heat dissipation energy on it, its amount being the sum of all the (actual) losses in the circuit. We could, furthermore, solve the problem of these losses if connecting serially to R_G a resistor R_G' , whose resistance would be negative and equal to the value of R_G by its absolute value. The overall resistance would then be zero, there would be no energy losses and the Q- factor would become infinite. The oscillatory circuit would, together with the components that create this negative resistance, become an oscillator capable of receiving SSB and CW signals.

We don't really need an infinite Q- factor while receiving usual (conventional) AM RG by its absolute value. The resistances would not cancel each other completely, but the losses would be made very small, the Q- factor therefore becoming very big therefor increasing both the selectivity and sensitivity of the oscillatory circuit.

Transistors T1 and T2 constitute, together with resistor R3, a two-stage amplifier with strong positive feedback that has a negative dynamic input resistance. This negative resistance is connected between the leg No.3 on the coil and the ground, therefore superimposing itself with the resistance representing losses of the circuit. The quantity of this negative resistance depends on the amount of the DC current flowing through the transistors, which is being regulated by altering the DC voltage on the right end of the R3 resistor (by moving the slider of the P1 potentiometer).

The red LED D and the resistor R2 comprise a simple voltage stabilizer, obtaining 1.8 V of stabilized voltage on the P1. That means that the voltage on the right end of R3 shifts between 0 and 1.8 V while moving the slider of P1. The current flowing through the transistors thereat also changes, causing the voltage on the left end of R3 to vary between 0 and 0.6 V.

The signal of the station is being led from the leg No.3 of the coil into the collector-type detector made of T3, R3, R4 and C4. That is an AM signal detector that performs both signal detection and its amplification. Its name is the Audion. The LF signal is then, from the collector of T3, over the coupling capacitor C5, being led onto the sound volume potentiometer P2 and the audio amplifier. For the latter any of the earlier described devices can be used.

Tuning this receiver on the desired station requires both some knowledge and patience (that's what finally "buried" this kind of receivers). Put the slider P1 in the upmost position. If strong whistling is heard that means the oscillating began. Move the slider carefully downwards until the oscillating stops. Then start slowly turning the rotor of the capacitor C until you come upon some station. If the whistling re-appears, move the slider of the potentiometer very little downwards, the

whistling should stop and you should be able to hear the radio - station programme from the loudspeaker (loud and clear). For the next station tune yourself with C, then move the slider P1 upwards until the whistling appears, then put the slider back until it stops etc. All this may seem rather complex at first, but with a little practice and with two hands all will go quick and smooth.

The abovementioned method is for the signal reception of ordinary, broadcast stations. If you wish to receive the SSB and CW signals you should move the P1 slider upwards until the oscillating is achieved, so that articulate speech (SSB) or Morse code signs (CW) can be heard from the loudspeaker.

* The coil L is being made on the cylindrically - shaped body 6 mm in diameter, about 25 mm long. The plastic - made body taken from an old device is the best, like the one shown on Pic.5.14-b. The screw-shaped core allows the setup of the inductance, adjusting therewith the reception bandwidth of the device. If you cannot find such coil body, any plastic- or carton- made cylinder can be used instead. If you don't have even that, then make yourself one. Cut the paper band to be 25 mm wide and about 150 mm long and reel it around the flat part of the 4 mm drill, adding every now and then some glue (UHU or similar). When the glue gets dry, remove the coil body off the drill.

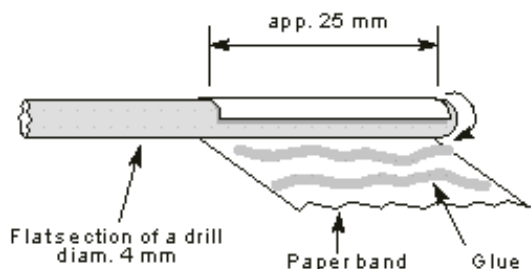

Pic.3.29-c. Spooling the coil body

The coil L has the total of 20 quorks of the lacquer - isolated copper wire, having 0.3 to 0.5 mm in diameter. A leg should be made on every fifth quork. Latching of the wire ends (with small holes made in the coil body), as well as leg making (by making wire loops) can be done acc. to the instructions given with Pic.3.6. It can also be accomplished differently, as shown on Pic.3.29-b. First, 4 separate coils, each one made of 5 wire rings, are made side-by-side on the coil body. The starts and ends are fixed with scotch tape. The isolation is then removed from all coil ends, about 5 mm in length, after which they are tinned. On the PCB the legs are being soldered in pairs, the end of one coil with the beginning of the next (they are put together in the same hole on the PCB). For example, the end of the second and the beginning of the third coil should be connected on the same line where contact for the left end of C3 capacitor is, thus creating the leg No.3 of the coil. Putting two wires through one hole is not a very professional solution. The "real thing" are separate junctions, one for each wire, as shown on Pic.3.29-d-c.

* The feedback may happen to be not big enough, causing that there's no oscillating even when the P1 slider is in the rightmost position. In that case, leg No.2 of the coil should be used instead of No.3. Switching between the legs can be done in many ways, the nicest (?) one given on Pic.3.29-d, made with factory-made contact pins and jumpers. On Pic.3.29-d-c you can see a detail of the PCB for the receiver shown on Pic.3.29-b. In the contacts marked as x, y and z (distance between them is 1/10 inch) the contact pins are soldered. The jumper is in position marked with dashed line, therefore making contacts x and y short-circuited. When it is moved in vertical position, the x and z contacts are in junction. In former case the coil leg No.3 is used, and in the latter it is No.2. In factory-made devices, these

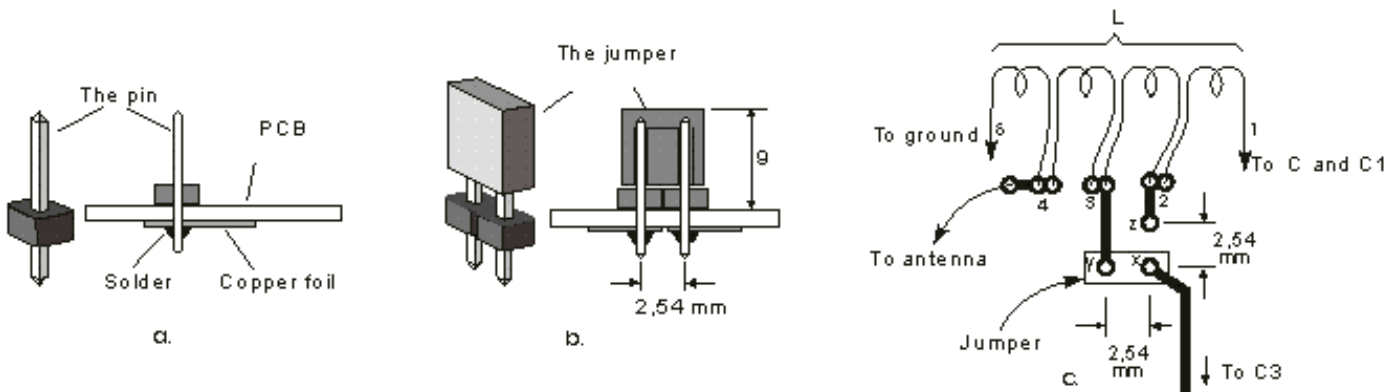

Pic.3.29-d. A- connector pin, b- pins with jumper, c- detail of the PCB from Pic.3.29-b

jumpers and contacts are used, together with appropriate connectors, to connect the PCB to the loudspeaker, power supply, variable capacitors, various switches etc.

* Setting the collector-type detector circuit to optimum operation is done by changing the R3 resistance, until voltage on the collector of BC549C is 1.2 V.

* The antenna can be a piece of copper wire no longer than 50 cm, but with longer (few metres), external antenna, the results will be much better.

* This receiver is scheduled for the reception of SW stations from 6 MHz till 9 MHz, which is accomplished with C1 value of about 400 pF. The exact value for C1 is being determined experimentally and can be significantly different. Going down to the amateur range (about 3.75 MHz) is performed with bigger C1 capacitance.

3.10. Miniature Receiver with ZN414 (ZN414Z) IC

The receiver from Pic.3.25 can be made portable (without an external antenna) if ferrite antenna is used instead of the carton-body coil, right? Well, not exactly. The ferrite antenna is a directional - type antenna, meaning that it does matter where are the waves made by transmitter coming from. The voltage being induced in it under the effect of EM field is the biggest if the ferrite rod is in horizontal position, aimed in such a manner that its axis is perpendicular to the direction of spread of the waves (i.e. perpendicular to the direction towards the transmitter). If the rod is being turned (in horizontal plane), the voltage decreases and gets to minimum when the rod is turned for 90 degrees, i.e. When the rod axis is parallel to the direction pointing towards the transmitter. That means that when the receiver from Pic.3.25 (with the ferrite antenna) is tuned to some station, the reception can be additionally improved by simply rotating it. The directional feature of the antenna is useful here. This, however, can be bad if the receiver is used in motion, since the volume would be constantly changing, and the receiver should be constantly turned towards the transmitter. It would clearly prove itself useful to have an electronic circuit in the receiver that would be automatically changing the amplification of the receiver, in such a manner that it would be increased when the signal in the antenna weakens and vice versa. This would even be convenient in the stationary - type receivers, since it would provide the constant sound strength in the loudspeaker during the reception of signals of various power. Such circuit does exist in modern receivers, and is called the Automatic Amplification Regulation circuit (AAR).

AAR circuit could be added to some of the receivers described in previous projects. The mishap is that electrical diagrams would then become significantly more complex, which would reflect itself both on the price and the realizability. The solution, however, does exist, and is rather simple: it's the ZN414 IC, being promoted as an "AM Receiver". Its block diagram is given on the Pic.3.30. The signal from the input

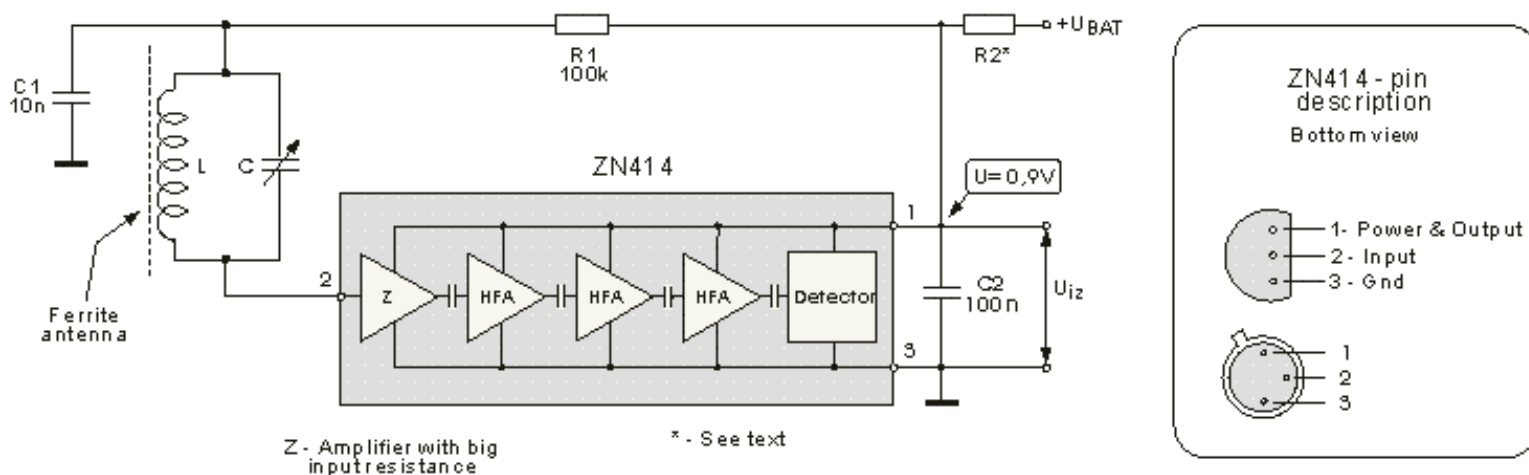

Pic.3.30. HF part of an AM radio receiver realized with the Zn414 IC

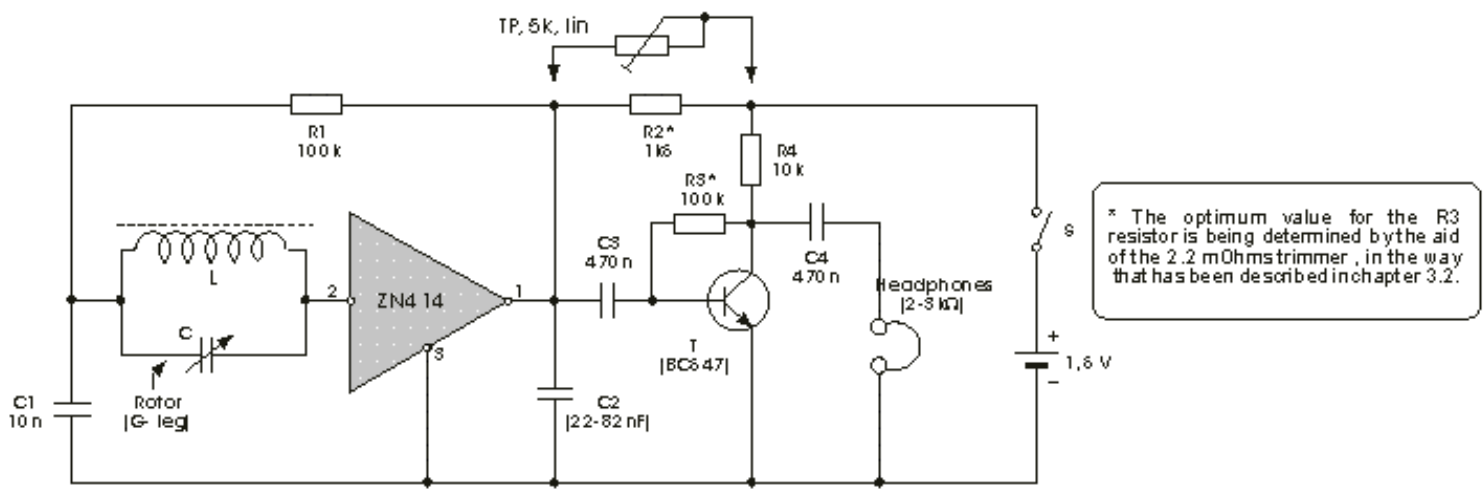

Pic.3.31. AM radio receiver with ZN414 IC

circuit (with ferrite antenna) is led on pin 2 of the IC, which is the input of the amplifier (Z) that has very big input impedance (about 4 MOhms). This is very significant, since such amplifier does not load the oscillatory circuit and doesn't reduce its Q- factor. The signal is then being amplified through 3-stage HF amplifier (HFA) and demodulated in the detector, thereby exiting the IC as an LF signal (music, speech...). In the right part of the Pic.3.30 the pin description of the ZN414 is given. As you can see, it is placed in a housing usually used for small-power transistors, either plastic (on top, like BC547) or metal (bottom, like BC107).

One end of the oscillatory circuit is connected to the ground over the C1 capacitor (for AC voltages), since input into the amplifier Z is between pin 2 and the ground, where the input signal is to be brought.

The automatic amplification regulation (control) is achieved by returning the DC component of the detected signal from the output to the input of the IC, over the R1 resistor. This DC voltage is being created on R2 resistor. It is substantial for the correct operation of ZN414, its resistance must be such that DC voltage on the pin 1 (to the ground) when no station is being received, is equal to 0.9 V. While calculating the R2 one must have in mind that the idle current of the IC goes through it, its typical value being 0.3 mA, and maximum 0.5 mA (more data about ZN414 can be found in table on Pic.3.36).

The electrical diagram of a small portable MW radio receiver, reproduction being done over the headphones, is given on Pic.3.31. The LF signal is led from the ZN414 output over the coupling capacitor C3 to simple amplifier made with BC547 transistor (or similar), which we discussed about before. This can even be done without the LF amplifier. If you have high-resistance headphones that are sensitive enough connect them between the right end of C3 and the ground, and omit the transistor, R3 R4 and C4.

The 1.5V battery is being used in this device, therefore the necessary 0.6V voltage drop is done with $R2=1.5$ kOhms. You should, just in case, connect first a 5 kOhms trimmer instead of R2, put its slider in the mid position, turn on the receiver and set it on an empty place on the scale, where no signal can be heard. Connect the voltmeter between the pin1 and ground, and carefully move the slider until the instrument shows 0.9V. If you have no instrument, tune the receiver to some station and move the slider carefully until you reach an optimum receipt. Then turn the variable capacitor's knob across the entire scale, to ensure that receiver is working well throughout the entire reception range. If everything is OK turn off the receiver, disconnect the trimmer, measure its resistance and solder an appropriate resistor on the PCB. While experimenting with R2 please have in mind that its resistance should be in any case no less than 600 Ohms.

On Pic.3.32 the PCB, ferrite antenna and look of entire device are shown.

If you plan to make a different PCB, since the device works on high frequencies, you have to obey certain rules in order to have a reliable and stable operation:

a. The splitting capacitor C2 has to be mounted as close as possible to the pin 1 of the ZN414. Its capacitance affects both the amplification (which increases with increase of C2) and the limit frequency of the LF signal (which decreases with increase of C2), so the compromise has to be found. You may put for start $C2=82$ nF (or even 100 nF), and if the reproduction quality pleases you - everything is in order. You could try with smaller capacitance, the amplification will decrease but the reproduction will be better, etc.

- b. All the connections, especially those near the ZN414, must be kept as short as possible.
- c. The ferrite antenna and variable capacitor should be placed as far away from the battery, loudspeaker (if existing) and the cables connecting them to the PCB.

d. The rotor (G- leg) of the variable capacitor must be connected with the junction of R1 and C1.

Regarding the ferrite antenna, the best thing would be using some that is retrieved from some disused conventional receiver, more on this was told in the project No.3.8. If you can't find one, or it is unsuitable for some reason, you can make it according to Pic.3.32-c. The length of the ferrite rod is 42 mm. If you have a longer rod, cut it down to size. This cannot be done with the saw, but a groove must be made with the rasp all around, after which the rod can be simply broken in two. The coil body is, again, made of paper tape that is spooled and glued onto the rod. Before you start with spooling, several pieces of 0.5 mm wire (3 on the picture) should be inserted between the rod and the paper. The coil has got 80 quirks of lacquer -isolated copper wire, its diameter being app. 0.2 mm. The beginning and the end of the coil are fixed with the scotch tape (the starting quirks are pressed on the coil body and fixed with several reels of 3 mm tape. The same is done with the ending ones). When the body is finished, the wires are removed. It is thus achieved that the coil body doesn't lay firmly on the rod, which can now be moved side-to-side, changing thereby the inductance of the coil, so that its optimum value can be established. If you still decide not to use the ferrite antenna, you can use our coil from Pic.3.6. In that case, the leg should be kept "in air", i.e. it is not used.

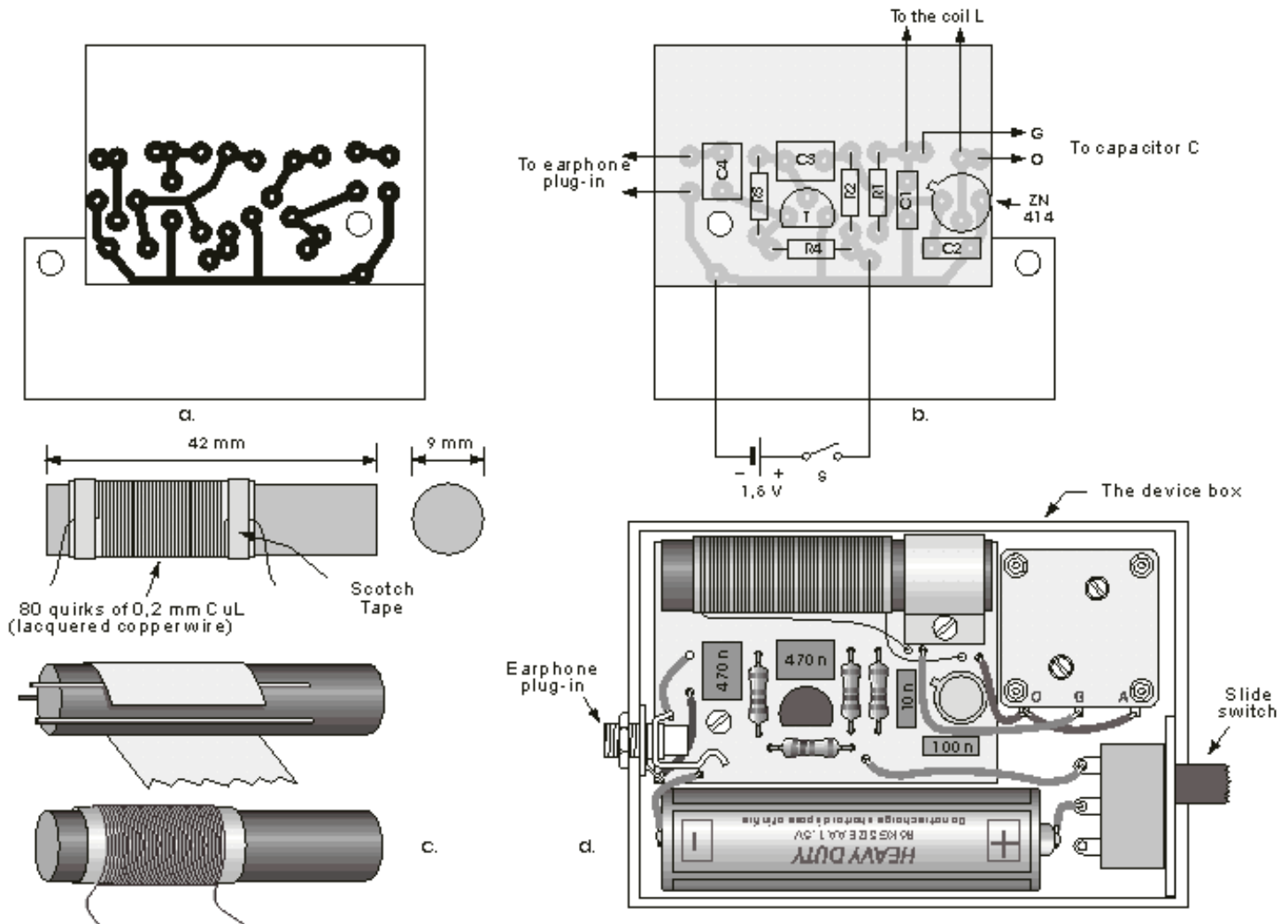

Pic.3.32. Practical implementation of the Radio Receiver from Pic.3.31-a: a- PCB (soldering side), b- PCB (component side), c- ferrite antenna making, d- complete device

* The battery can be connected to the PCB with two pieces of wire that are soldered to it. This solution is fine if you are skilled in soldering and can easily un-solder the old battery and attach the new one. But if you intend to give the receiver to someone, and he/she is not a soldering-lover, you'll have to find another solution. The simplest thing to do is take the battery housing from an old receiver, do the necessary adjustments and connect it with the PCB with two pieces of flexible (litz) wire. If you cannot do the former, make two battery platforms of brass, as shown on Pic.3.33 and solder them on two copper areas on PCB that are big enough to support them. If you accept this solution, your PCB must be bigger (The additional part is shown in dashed line, on Pic.3.32-a). The board now also contains the holes for the screws, which are fixing it onto the device box. On the platform that supports negative (-) battery pole, a small spring can be attached, to provide a good contact. If you don't have such a spring, bend the platforms inwards a little, to keep the battery firmly in place.

If you are using a power source whose voltage is greater than 1.5 V, the R2 resistance should be increased. The exact value for it is best to find as previously described, by using the 50 kOhms trimmer. Even better solution is using one of the circuits from the Pic.3.34. Which one should it be? The one on the Pic.3.34-d gives the best operating performance. The setting is done with the TP trimmer. The slider is put in the lowest position, and then is slowly moved upwards until the voltage on the pin 1 doesn't reach the level required. However, this circuit applies a big load onto the battery, surging from it the current $I = (9V - 3V) / 680\Omega = 8.8 \text{ mA}$.

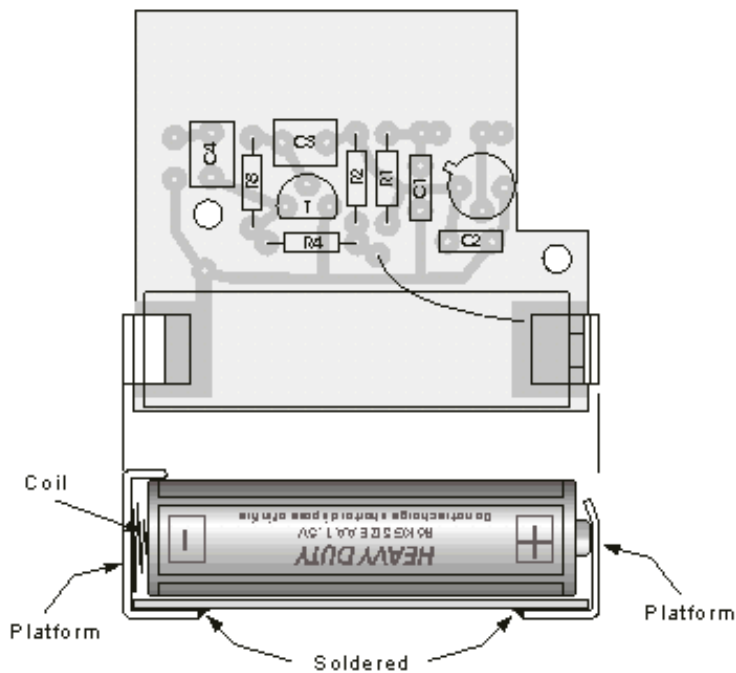

Pic. 3.33. Battery mounting on the PCB

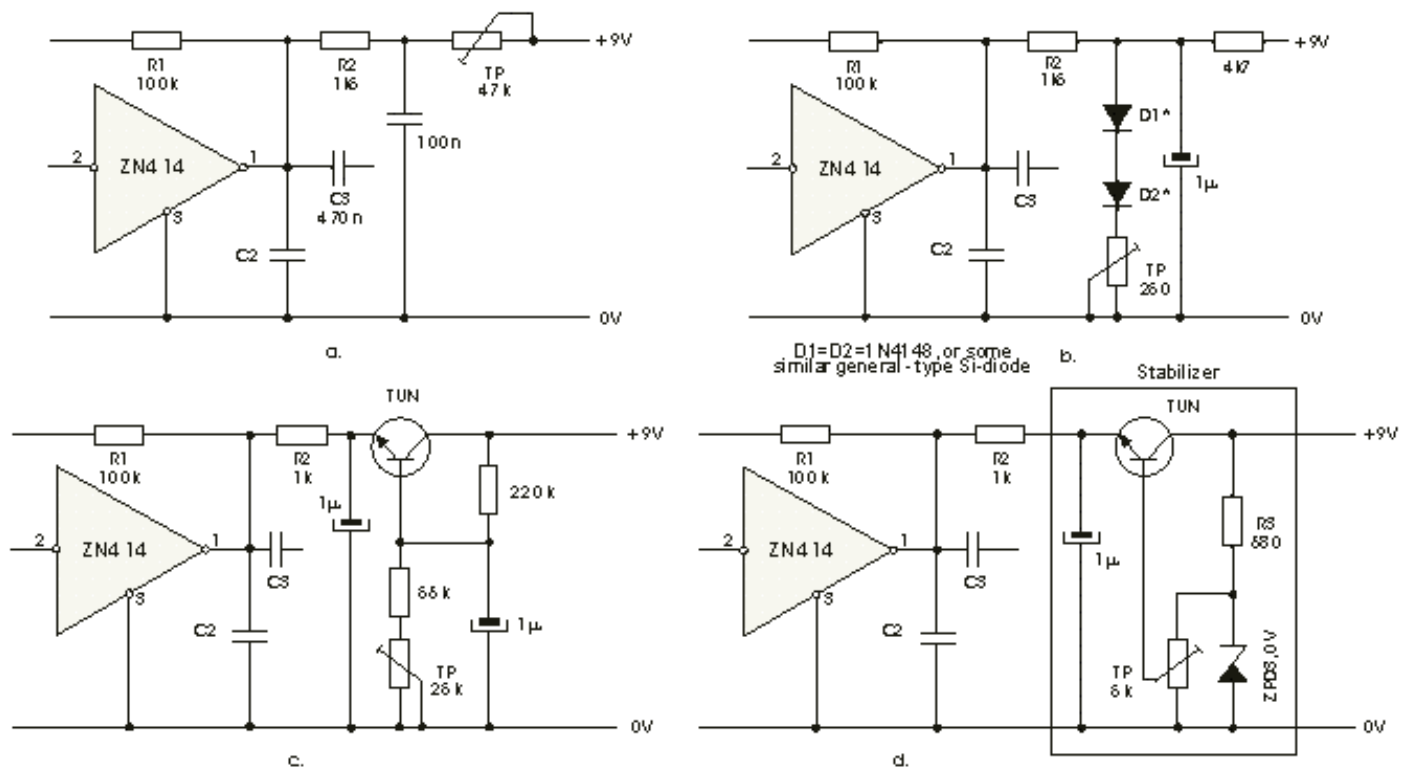

Pic.3.34. Power supplying the ZN414 from the 9V battery: a- with the resistor divider, b- with a two-diode stabilizer, c- with the transistor voltage attenuator, d- with the stabilizer with a transistor and the Zener - diode

3.11. Pocket Receiver with ZN414 & LM386 IC's

The author was taking notes in his lab while testing the receivers being described herein, and used them later to write this book. One remark about the receiver whose electrical diagram is given on Pic.3.35 was: "Works EXCELLENT". The reader will probably ask himself: Isn't this the aforementioned "The Best Receiver"? No, it isn't, just remember: DE GUSTIBUS... If, however, you consider it to be "The One", please send your vote on E-mail: tesla@drenik.net;

This device is very similar to the one being described in the previous project. The most important difference is that the LF signal exiting the ZN414 does not go to the transistor amplifier but to the power amplifier built around the LM386, which was used in some previous projects. Any other audio amplifier can be used instead, e.g. those on Pics. 3.15, 3.21 and 3.22. With this receiver, special care should be taken regarding the voltage on pin No.1. As you did in previous project, put the potentiometer's slider in mid-position, turn the receiver on and tune it to some station. Move the slider carefully, until you reach the optimum reception. Start changing the capacitance of the variable capacitor, covering its entire scope, to make sure that receiver works well in its entire operating range. If a problem occurs, re-position the slider again. When everything gets OK, turn the receiver off, disconnect the potentiometer, measure its resistance, and solder the resistor of such resistance on the board. The R2 resistance must be no less than 600 Ohms.

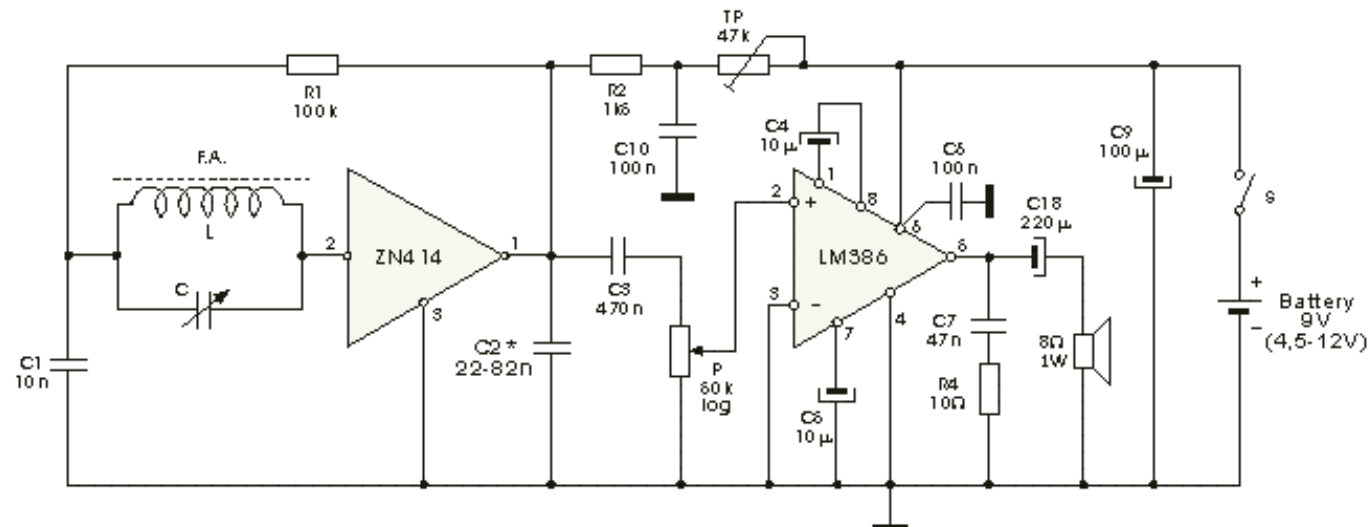

Pic.3.35. The AM Radio Receiver with ZN414 and LM386 IC's

3.12. Miniature Receiver with ZN415E (ZN416E) IC

The ZN415 IC, being promoted as “The World’s smallest radio” by its manufacturer (FERRANTI), is an improved version of ZN414. As seen on the Pic.3.36-a (IC’s block diagram), the 8-pin DIL package contains ZN414 IC with R1 and R2 resistors, an amplifier with T1 transistor and the separation stage performed with T2 transistor. All the necessary resistors are comprised in the IC. Someone will, perhaps, wonder why there are no capacitors integrated inside, so that the externally mounted parts would then be only the battery and the headphones. The answer is fairly simple: It isn’t yet possible to make the capacitors that would have enough big capacitance, in the monolithic IC’s manufacturing process. Regardless of this “problem”, the receiver built around the ZN415 is, really, extremely simple.

As described in project 3.10, the LF signal exits the ZN414. Through the coupling capacitor C3 it is led on the base of T1, and the amplified signal is obtained on its collector pin, and is taken directly on the base pin of T2. The remains of the HF signal are led to the ground over the C4 capacitor. The separation stage allows us to connect small - resistance (64 Ohms) headphones, which are mass - produced these days and are the easiest ones to obtain.

The 1.5 V battery is used for the power supply of the circuit, and is being connected between the pins 6 and 4. Having in mind the previous experience gained with the ZN414 IC, the author recommends to the readers to try improving the signal reception by adding the R2* resistor (helping themselves with linear 1-5 kOhms potentiometer), which is shown in dashed line on the picture.

In the upper end of the Pic.3.37 the table with basic data about ZN415 circuit is given. All these apply on the ZN414 as well, except for the last line. The smaller table given below it contains the data about the DC voltages on the pins of the IC. If something is wrong, the first thing to do is check these voltages and if they are (approximately) as those given in the table, the IC is OK and the error is therefore to be searched in the printings, the contacts, junctions, etc.

Everything that is said about the ferrite antenna in the previous projects applies here as well.

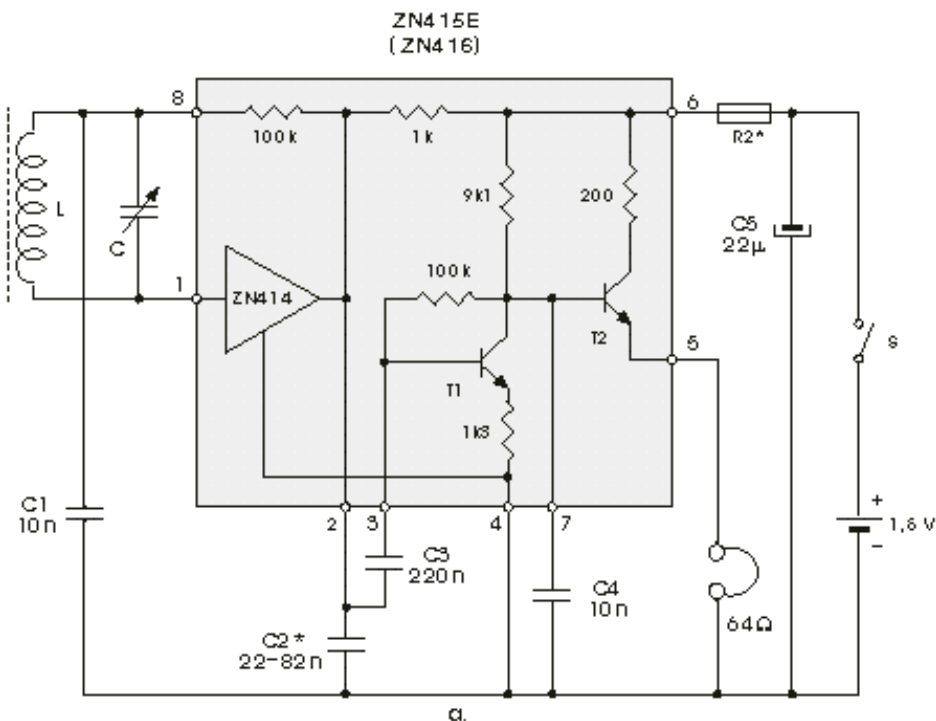

Pic. 3.36 Miniature AM receiver with ZN415E IC

The ZN415E (ZN414Z) features

Parameter	min.	tip.	max.	unit
Supply voltage	1,1	1,3	1,6	V
Current consumption		4 (0,3)	5 (0,5)	mA
Frequency range	150		3000	kHz
Input resistance		4		MOhm
HF power amplification		72		dB
LF voltage amplification		18		dB

* Data in the parenthesis are for ZN414Z

Pin	U(V)
1	0,75
2	1,1
3	0,7
4	0
5	0,2
6	1,5
7	0,9
8	0,75

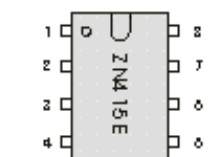

The DC voltages on ZN415E pins

Pic. 3.37. ZN... IC's data

3.13. AM Receiver with ZN415E & LM386 IC's

This FRT AM receiver combines the features of two magnificent IC's, ZN416E (HF amplifier, detector and the pre-amplifier) and LM386 (audio power amplifier). Add a power supply based on 7809 voltage stabilizer IC, use a loudspeaker with membrane diameter being about 15 cm, put all this in one of the boxes described in the Appendix, and you will have a new and improved silicone - based model of an old - fashioned radio receiver, built somewhat less than 100 years ago.

The electrical diagram of this device is given on Pic.3.38. The voltage reduction (and stabilization) from 9V to 1.5V, as needed by ZN415, is being done over the R2 resistor and D1 and D2 diodes, although any circuit given on Pic.3.34 can be

used instead. Universal - type diodes 1N4148 are used here, but any other low-power silicon diodes will do. With 250 Ohms trimmer TP the fine - tuning of the voltage on the pin 6 is being done (the receiver is set to some station in the upper part of the reception bandwidth (app. 1500 kHz), and the slider of the TP is then used to obtain the optimum reception). After that, the receiver is switched off, the trimmer is disconnected, its resistance measured and an equivalent resistor soldered in the circuitry. On the PCB, this resistor is marked as R3.

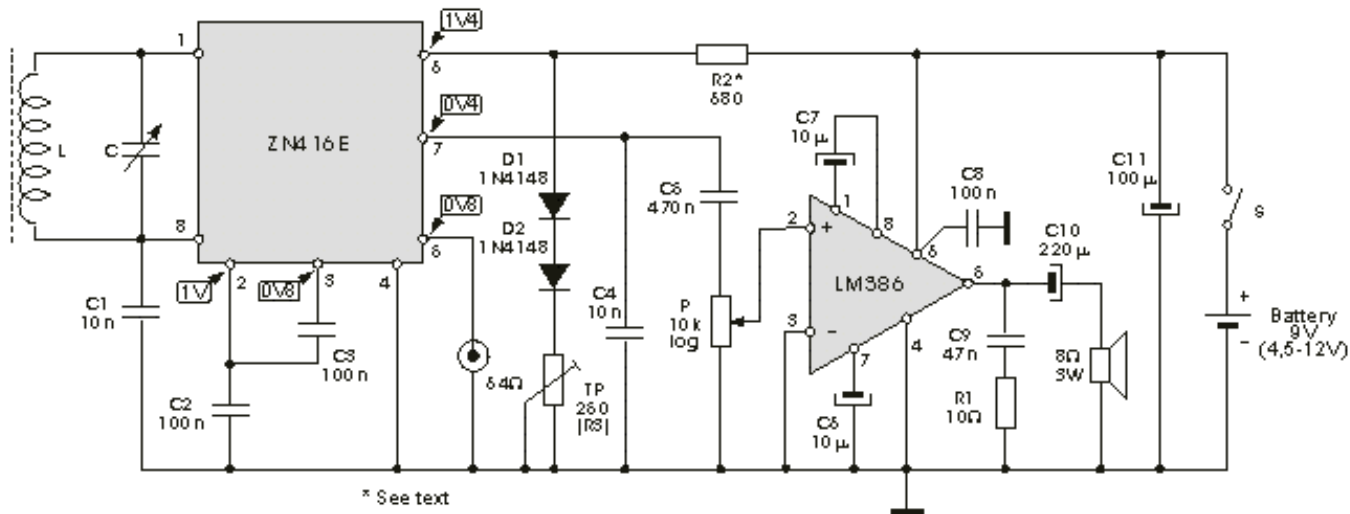

Pic. 3.38. AM radio receiver with ZN415E & LM386

The PCB, component layout and connections with other parts of the device are shown on Pic.3.39. If the receiver is made for the household use, you should certainly put it into some bigger box where bigger loudspeaker (~ 15 cm) can be installed. The ferrite antenna should be mounted on the rear or side panel, as far from the loudspeaker as possible. All the conductors, especially those that connect the capacitor to the board, should be as short as possible. The wires that connect the loudspeaker and the adapter to the PCB have to be firmly twisted, as shown on picture for the loudspeaker. The potentiometer is to be connected with the shielded microphone cable, if it is more than 10 cm away from the board.

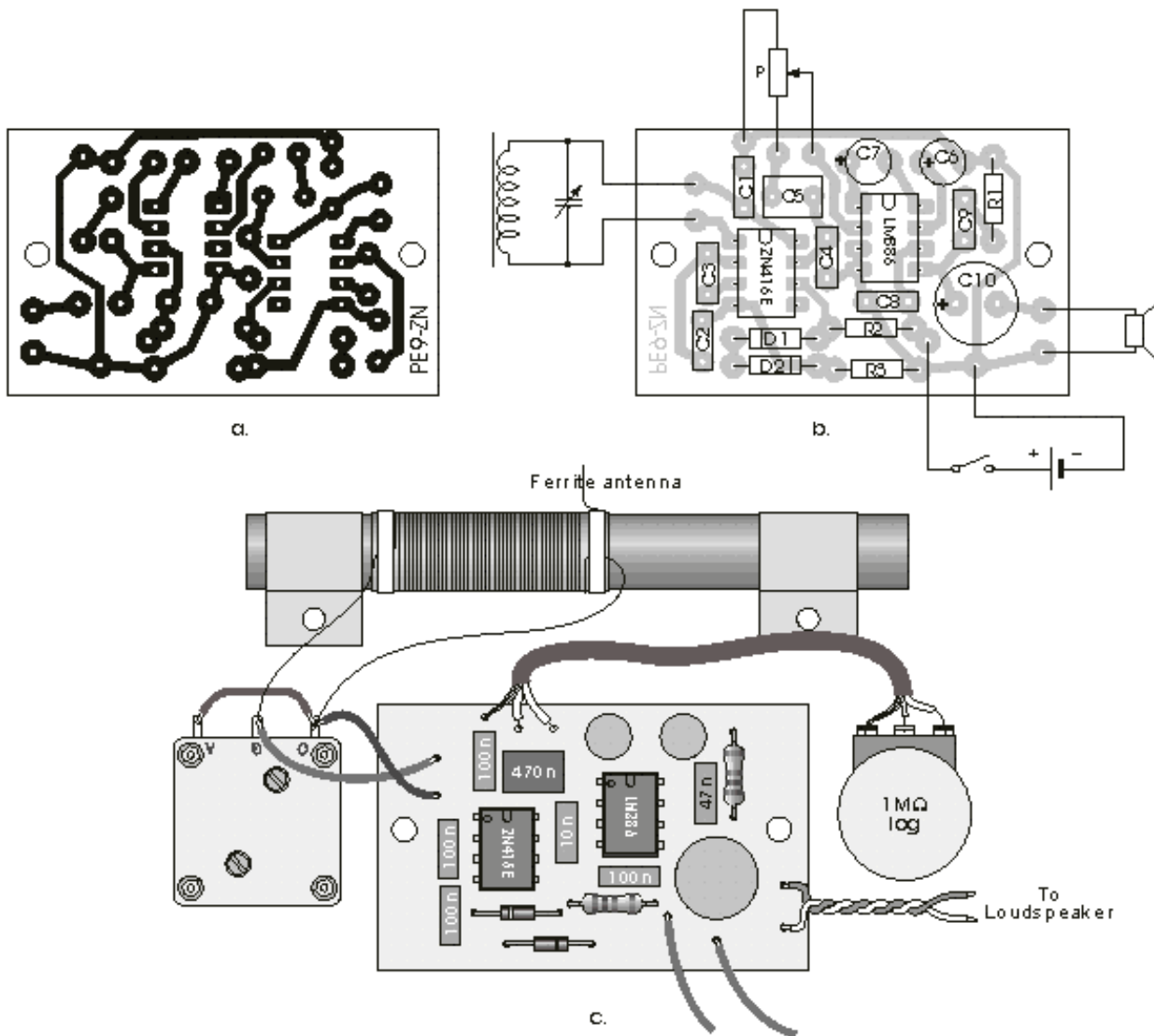

Pic. 3.39. Practical implementation of the receiver from Pic. 3.38: a- PCB (solder side), b- PCB (component side), c- "Real" layout

A connector for 64-Ohm headphones can also be mounted on the box. It is then connected to the PCB via a microphone cable, connecting its "live" end directly on pin No.5, and the shield wire to the closest ground. Headphones can also be used instead of loudspeaker, in which case such connector must be chosen, that will switch off the loudspeaker when headphones are plugged in.

* Some more modern IC, other than LM386, can also be used in this device. The author recommends TDA7052A. Its main features are:

1. Extremely stable operation
2. Implemented output short-circuit protection
3. No cooler necessary
4. Small power consumption, $I_{O} = 4 \text{ mA}$
5. No "clicking" during switching ON/OFF
6. Voltage amplification is 39 dB
7. Output power $P_{iz} = 1.2 \text{ W}$ (3x bigger than LM386)
8. The 220 mF capacitor isn't needed if the power rectifier that has an electrolytic capacitor on its output is used, and the cables connecting it with the device are short. In that case the amplifier is practically made without the external components, if we exclude the (inevitable) 100 nF capacitor, which is in every way great advantage.

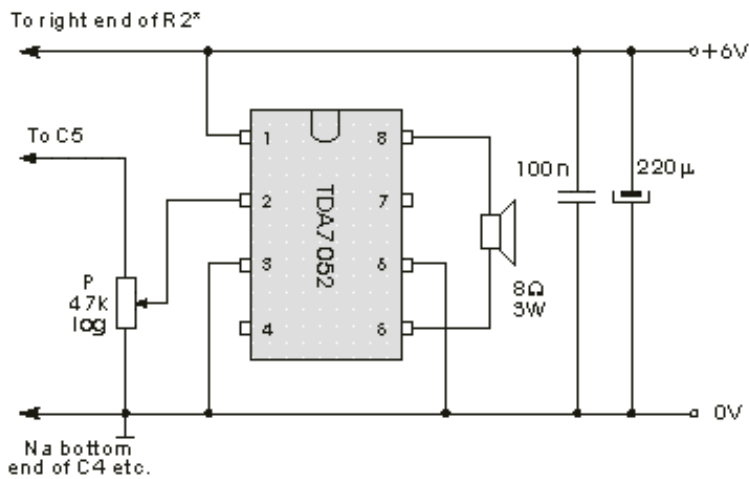

Fig. 3.40. LF part of the receiver from pic. 3.38.

3.14. Miniature receiver with ZN415E & TDA7052 IC's

The 9 V battery is not so popular nowadays as it used to be, probably for its quite big price/capacity ratio, so it is almost never used in the pocket-type receivers today. Much more frequently utilized these days are the cylindrically shaped 1.5 V AA type batteries. Electrical diagram of one pocket-type AM receiver that uses two of these for power supply is given on Pic.3.41. Two IC's, ZN415 and TDA7050 are being used in it. The DC supply voltage for TDA7050 must be exclusively 3 V, and should be no bigger than 4 V. The voltage being supplied from the batteries gets smaller during the use, but the IC operates properly as long as it doesn't drop below 1.6 V. Besides this nice feature, this IC has very small dimensions, very low idle current (4 mA), all the external components it requires are two capacitors (C8 and C9), which makes it ideal for usage in the mobile-type devices (radios, wakmans, etc.), the purpose that is originally designated to it by its manufacturer (Philips).

* Caution must be expressed with the power supply, since this two-batteries power supply cannot be simply replaced with some common-type 3V adaptor. If you wish to use such adaptor, the pin 6 of ZN414 must be connected, over the R2 resistor and one of the circuits from Pic.3.35, to the pin 8 of the TDA7050, and the adaptor is then to be connected between the pin 8 and the ground.

* The R2* resistor, shown in dashed line on the picture, should be added only if the receiver does not operate stable.

Determining its exact value is explained in several previous projects.

* The 64 Ohm headphones are connected onto the output of the ZN415 (between pin 5 and Gnd), or instead of the loudspeaker (in which case the reproduction can be much louder).

* The PCB and components layout is shown on the Pic.3.42. Connecting other components is being done in the similar manner as in the previous project. In the left corner the batteries are shown, placed in some convenient holder taken from some old device. Between the plus pole of the left and the minus pole of the right battery the tin plate is inserted, with one of 3 cables connecting the supply to the PCB soldered to it.

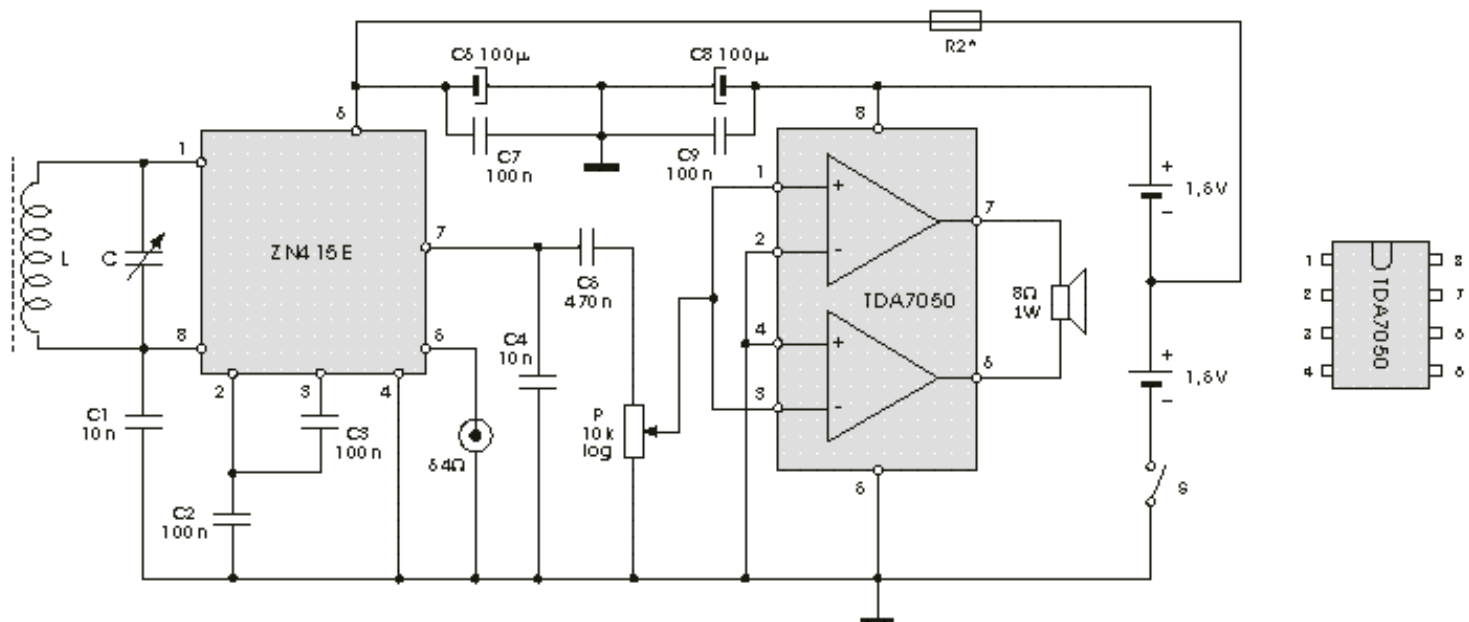

Pic. 3.41. AM receiver with ZN415E i TDA7050

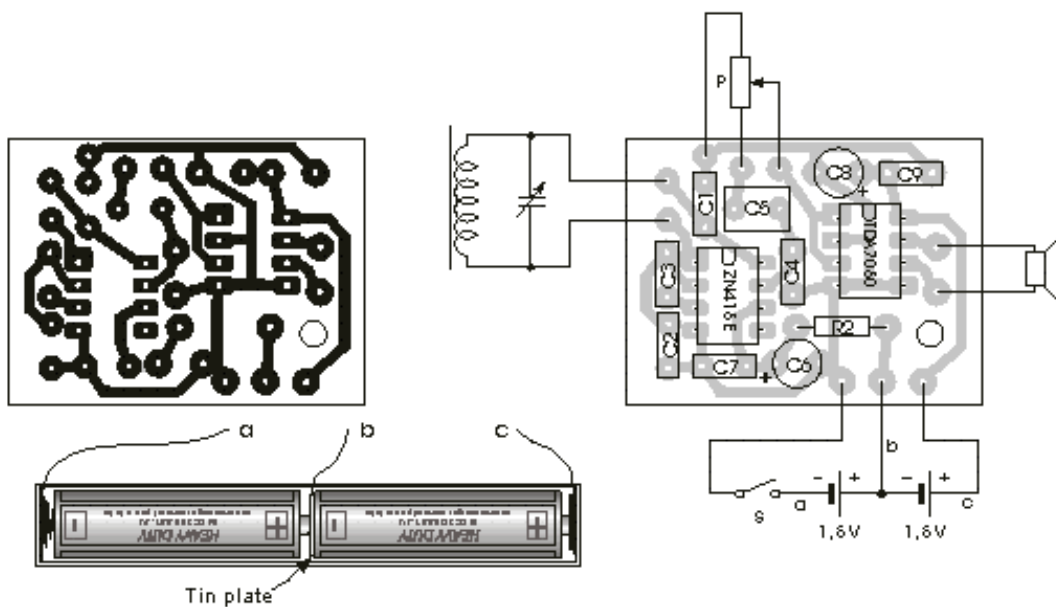

Pic. 3.42. The PCB for the device from pic. 3.41

Nabavka preko 100 000 komponenta iz kataloga

RS COMPONENTS

3.15. Direct (TRF) FM Receivers

Frequency modulation is used in radio broadcast in the bandwidth range from 88 MHz til 108 MHz. This range is being marked as "FM" on the band scales of the radio receivers, and the devices that are able to receive such signals are called the FM receivers.

Radio broadcast transmitters are using the amplitude modulation on LW, MW and SW bandwidths. According to international treaties, each of the transmitters has a 9 kHz wide broadcasting channel, therefore making maximum frequency of the information being transferred $f_{NFmax}=4.5$ kHz, according to the characteristics of the AM signal. To put it more simple, the highest frequency of the sound that can be heard from the loudspeaker of an AM receiver is 4.5 kHz, all above it will be simply truncated in the circuitry. Considering the speech itself, this isn't so important since the most important components are located below these 4.5 kHz (during the telephone transfer, all the components above 3.2 kHz are being cut, and nobody is complaining). Things stand different, however, for the transfer of music. Music has much more sound components, with their frequencies spreading up to 15 kHz, so truncating them above 4.5 kHz does deteriorate the transmission quality.

The radio-broadcast FM transmitter has a 250 kHz wide channel on its disposal, therefore allowing for the maximum frequency of the information (acc. to the characteristics of the FM signal) to be $f_{NFmax}=15$ kHz. That means that music is being fully transferred and its quality is significantly better than in the case of the AM transfer. The FM transfer has some other advantages, perhaps the most significant of them being the possibility of eliminating various disturbances that are manifesting themselves as snapping, squeaking etc. The main disadvantage, however, is not the result of the frequency modulation itself, but rather of the fact that this method is being used on high frequencies, and that high-frequency electromagnetic waves behave themselves as light, spreading themselves in straight line, not reflecting from the ionosphere etc. This is why obtaining this kind of radio-link requires optical visibility between the transmission and reception antennas, which is not the case for the links obtained on frequencies which are less than 40 MHz. In practical terms, it is possible to receive the SW signal from anywhere on Earth, whilst the range of an UHF link is limited to the horizon. Or, as Hamlet would say: "The quality or the range, that is the question!"

Can we have it both, somehow? Yes we can, and it is already being done, over the satellite links, using the same equipment as for the TV signal receipt and an audio amplifier connected to the audio output of the satellite receiver. For now, in the earthly conditions, those that are interested in the worldwide news will make and use the AM receivers, and music lovers will stick to the FM's. And what can those interested in both do? Well, they make AM-FM receivers :)

The direct-type (TRF) FM receivers have never been produced, the industry started right away with the superheterodynes, made acc. to the block diagram on Pic.4.6, which will later be discussed. In amateur life, however, the direct FM receivers do exist, having very simple electronic diagrams and being easy to manufacture. These receivers have very strong positive feedback, making the intermittent oscillations in it, and are therefore being called the super-reaction receivers.

3.15.1. The Simplest FM Receiver

On Pic.3.43 you can see the electronic circuit of an extremely simple direct FM receiver. The T2 transistor together with the R1 resistor, the coil L the variable capacitor C and internal capacitances of the T1 transistor, comprises the so-called Kolpitz oscillator. The resonance frequency of this oscillator is being set by C to correspond to the one of the station that we wish to hear (meaning it has to be altered between 88 and 108 MHz). The signal, i.e. the information being used in the transmitter to perform the modulation, is extracted on the R1 resistor, and being led from it to the high-resistance headphones, over the coupling capacitor C1.

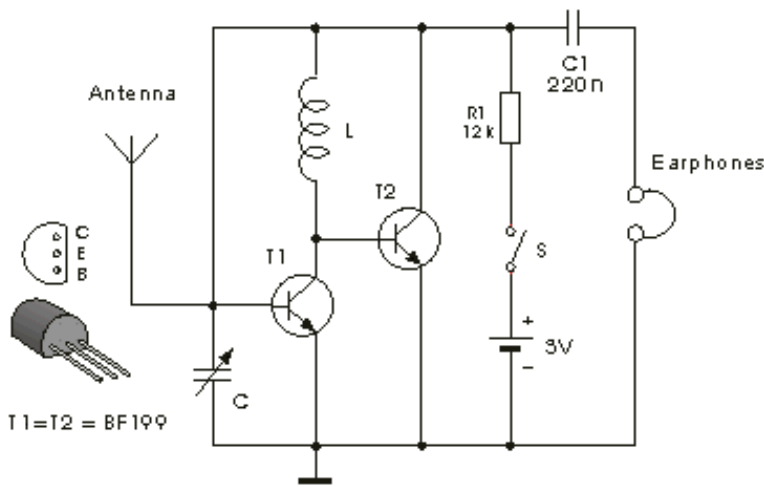

Pic.3.43. The simplest FM receiver

- * The capacitance of the variable capacitor should be able to change from a couple of pF (Cmin) to app. 20 pF. During the testing off this device, we were using the capacitor from Pic.3.8. The legs marked as FO and G were used, the G leg being connected to the ground. When all the trimmers from the circuit on the Pic.3.8 are set to minimum capacitance, the capacitance between the FO and G legs should be adjustable between 7 and 27 pF.
- * The coil L has 4 quirks of lacquer-isolated copper wire (CuL), bended to have a 4 mm internal diameter. The practical realization of this coil is explained in text connected with Pic.3.45. During the setup of the bandwidth, the inductance of the coil can be altered by changing the distance between the quirks. If the coil is stretched the inductance decreases, and vice versa. If this cannot give the desired results, new coil must be made.
- * The telescopic antenna taken from a disused device can be used. If you can't find one, you obtain very good results with a piece of isolated copper wire, about 60 cm long (the optimum length to be found experimentally).

3.15.2. The Simplest FM Receiver with Audio Amplifier

The radio-broadcast FM transmitters operate with output power that is much smaller than that of the AM transmitters. That is why the LF signal coming from the device on Pic.3.43 is rather small, urging the use of very sensitive headphones. They are much more expensive than the "ordinary" ones, making it better to use the cheap headphones in connection with audio amplifier. One such solution where TDA7050 IC is used is given on the Pic.3.44. The R3 resistor and capacitors C5 and C6 are to be added only if the operation of the device is unstable. There optimum values are to be found experimentally, starting with those shown in the picture.

For loudspeaker reproduction any of the previously described amplifiers can be used, e.g. that from Pic.3.21 (which we have been using, very successfully), or one of the devices described in P.E.4 and P.E.5. Since in these amplifiers a battery with voltage bigger than 3 V is used, using of R3 and C5 is obligatory. The R3 is counted from the formula

$$R_3 = \frac{U_{BAT} - 3}{0,235} [k\Omega]$$

where U_{BAT} is battery voltage, and 0.235 mA is the current through R1, that supplies T1 and T2. E.g. if U_{BAT}=9 V, it is then and the nearest existing resistor is used.

$$R_3 = \frac{9 - 3}{0,235} = 25,5 k\Omega$$

Capacitors C5 and C6 comprise, together with R3, a pass-filter for very low frequencies, which is used to separate the HF and LF parts of the receiver.

The battery itself acts as a short-circuit for the AC currents. But when it ages its resistance increases and there is no more short-circuit. That is why C3 and C4 are added, to accomplish it.

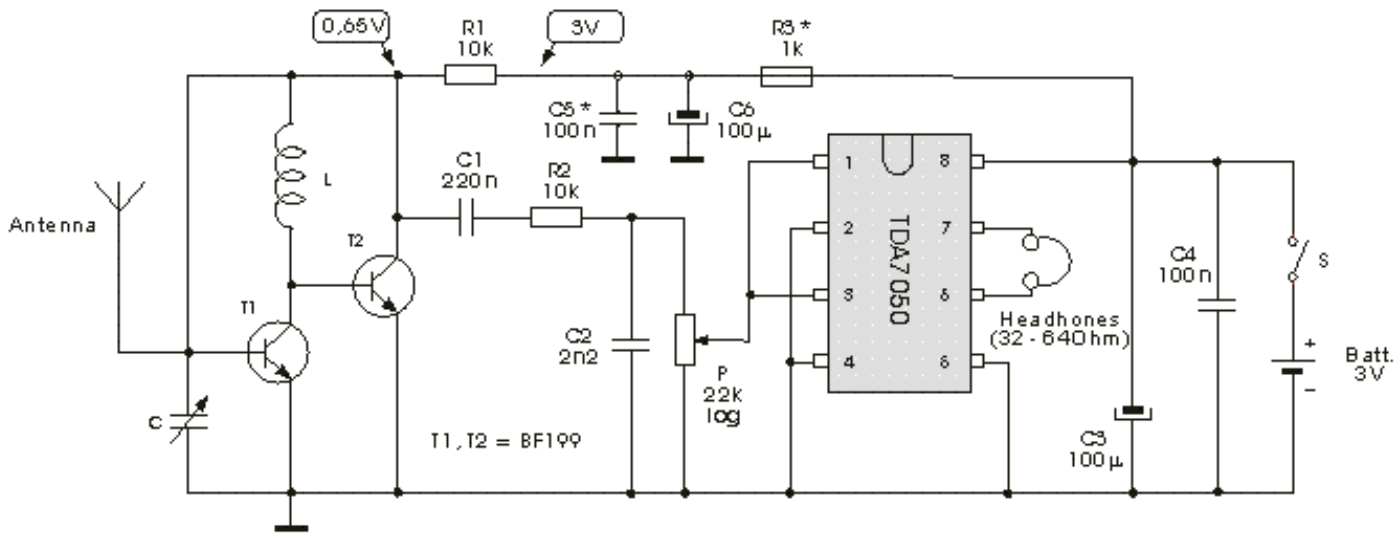

Pic. 3.44. The simplest FM receiver with audio amplifier

3.15.3. FM Receiver with one Transistor and Audio Amplifier

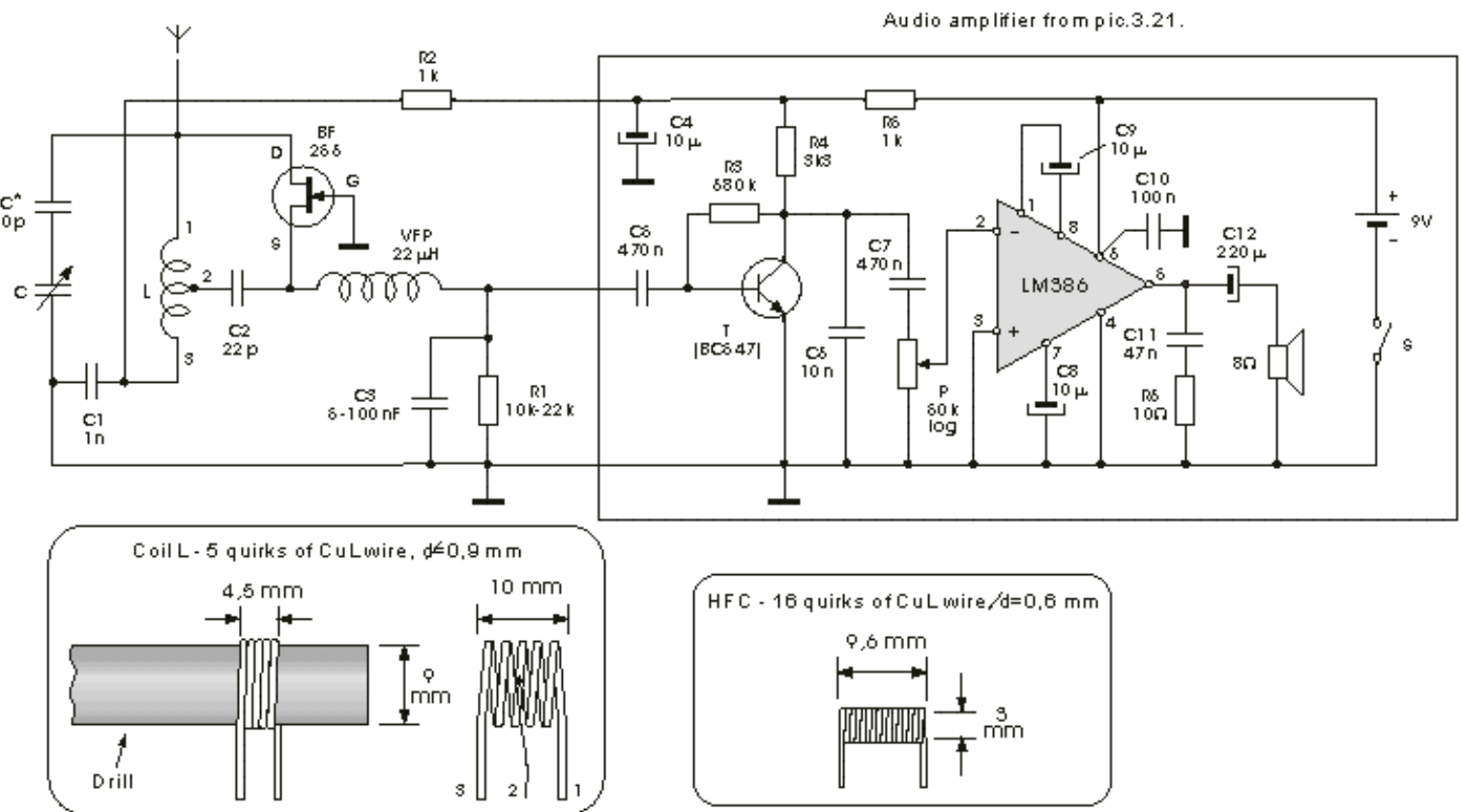

Pic. 3.45. FM radio receiver with audio amplifier

We have made this receiver on the experimental plate, and it was playing for days in our lab. Its electronic diagram is given on Pic.3.46. Regretfully we had to disassemble it, since we needed the plate for one of the devices described later in this book. This, too, is a reaction-type receiver, where the BF256 transistor, coil L and capacitors C, C* and C2 form the Hartley oscillator. Its frequency is being adjusted by means of the variable capacitor C to be equal to the frequency of the station that we wish to listen to. The LF signal is being taken from the R1 resistor, and led into the audio amplifier.

* The coil L is self-supporting (doesn't have the body), made of 5 quirks of CuL wire, its diameter being from 0.8 to 1 mm. It is spooled on some cylindrical object (pencil, pen etc., the best thing is the round part of a 9 mm drill), in one layer, quirks put tight to each other, as shown in the left, framed part of the picture. When the coil is finished, it is taken off the cylinder and stretched a little, so that the quirks do not touch each other. Its final length should be about 10 mm. The mid coil leg, which is to be connected to the left end of the C3 capacitor, is made by taking off couple of millimetres of the lacquer from the wire, approximately in the middle of the coil. This place is then tinned and a piece of thin wire is soldered to it. The other end of this wire is soldered onto the PCB, on its place, to be connected to the left end of C2.

* For the variable capacitor C the one from the Pic.3.8 (legs FO and G, G goes to Gnd). If you are using some other capacitor, that has bigger capacitance, and you cannot achieve the reception of the full FM bandwidth (88 til 108 MHz), try changing the value of the C*. Its capacitance is to be determined experimentally, usually being about a dozen pF.

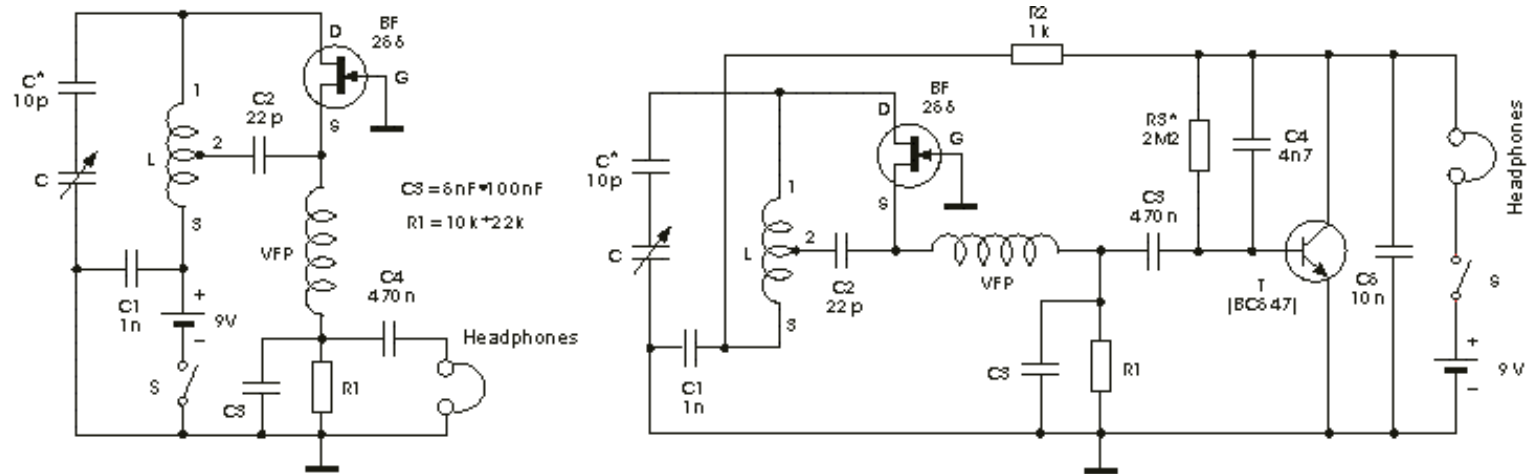

Pic. 3.46. FM receivers with headphones

* HFC is the high-frequency choke. Together with C2, it makes a filter that prevents the HF current to flow through the R1, simultaneously allowing for DC and LF current to go through. The muffler is, in fact, a coil that has 16 quirks of 0.6 mm CuL wire, spooled on a round part of a 3 mm drill.

* This receiver works well even without the external antenna. It can, of course, be connected to it, as shown in dashed line. Instead of antenna, a 50 mm piece of wire can also be used.

3.15.4. FM Receiver with (just) one Transistor

On the left side of the Pic.3.46 you can see the diagram of another very simple FM receiver, that has only one transistor as the active element. That is, as one can see, the HF part of the receiver from Pic.3.45, where the reproduction is being accomplished over the high-resistance headphones. But, as previously noticed, they are pretty expensive, therefore making it better to use the "regular" headphones and a simple amplifier, as shown on the right side of the Pic.3.46.

Chapter IV SUPERHETERODYNE RADIO RECEIVERS

[4.1. Superheterodyne AM Receivers](#)

[4.1.1. The Simplest AM Superheterodyne Receiver \(worldwide\)](#)

[4.1.2. The Fully \(not exactly 100%\) superheterodyne AM Receiver No.1](#)

[4.1.3. The Fully \(not exactly 100%\) superheterodyne AM Receiver No.2](#)

[4.2. Superheterodyne FM Receivers](#)

[4.2.1. FM Receiver with TDA7000](#)

[4.2.2. FM Receivers with TDA7088T](#)

[4.2.2.1. Miniature FM Receiver](#)

[4.2.2.2. Stereophonic Receiver](#)

As far as the professional manufacturers are concerned, the direct (TRF) receiver has "played out his tune". After half-century struggle on the market, it has been replaced by the superheterodyne receiver, that was patented in 1918 by Edwin Armstrong. In that time, commercially speaking, its main advantage was its substantially easier tuning to the station. It requires only one button for this, comparing to the TRF receiver that needs two buttons to be intermittently adjusted for optimal reception, and also it requires much of the knowledge, skill and patience, which the average buyer does not have. The superheterodyne receiver is, however, also more complex than the TRF, and setting of its stages during its production requires some special instruments, that the average radio amateur does not possess. Nevertheless, it is not impossible to build such device in the amateur environment, and when the operating principles are known, the necessary adjustments can be done "by hearing".

4.1. Superheterodyne AM Receivers

On Pic.4.1 you can see the block diagram of a radio-broadcast superheterodyne receiver. The input circuit (UK) refines the signal of the tuned station from all the voltages created in the antenna (A) by various radio transmitters and sources of disturbances. In our example, it's an AM signal that has the carrier frequency f_s , and is modulated by a single tone, as seen in the rectangle above its label. This signal is being led into the stage called the mixer. Another voltage is also led into it, the voltage from the local oscillator that has the frequency of f_0 , and a constant amplitude. Under the effect of these two signals, the phenomenon called the outbreak takes place in the mixer, and an AM signal appears on its output, its frequency being $f_m = 455 \text{ kHz}$. This signal is called the inter-frequency (IF) signal, and its frequency f_m the interfrequency. The IF signal has the same envelope as the station signal entering the mixer. That means, that the information from the transmitter to the mixer is carried by the signal frequency f_s , and in the mixer it is being assumed by a new carrier, that has the frequency f_m . When transferring to another station, the user changes the capacitance of the variable capacitor C by turning the knob, setting up the resonance frequency of the input circuit to be equal to that station's one. Another variable capacitor, C_0 , is located on the same shaft as C, so its capacitance changes simultaneously to that of C. This capacitor is located in the local oscillator and that is how it gets the new oscillating frequency, having such value that the difference of the oscillator and station frequencies is again equal to the inter-frequency value.

Here's one numerical example. The interfrequency is being adopted by the constructor of the device, and it is mostly $f_m = 455 \text{ kHz}$. When the receiver is set to the station that has the frequency of $f_m = 684 \text{ kHz}$, the frequency of the local oscillator shall be $f_0 = 1139 \text{ kHz}$, therefore making their difference be $1139 \text{ kHz} - 684 \text{ kHz} = 455 \text{ kHz} = f_m$.

When tuning to a station that operates on the frequency of $f_s = 1008 \text{ kHz}$, the listener will change the capacitances of the two capacitors until the resonant frequency of the input circuit becomes $f_s = 1008 \text{ kHz}$, and the oscillator frequency $f_0 = 1463 \text{ kHz}$, therefore yielding $1463 \text{ kHz} - 1008 \text{ kHz} = 455 \text{ kHz} = f_m$.

If the receiver has more wavebands (LW, MW, SW1, SW2...) it is being constructed to have the same inter-frequency value for all of them.

What do we gain with this change of the carrier frequency? So far we haven't mentioned one very important thing, that is that the input circuit can never be selective enough, to extrapolate only the signal of the tuned station, from all the signals that exist in the antenna. On the output of this circuit, besides the station signal, also signals of strong and local transmitters are obtained, especially the signals from the neighbouring channels (their frequency being very close to the one of the tuned station). All these signals are receiving new signal carriers in the mixing stage, with their frequencies deviating f_m as much as their carrying frequencies differ from f_s . E.g., if the input circuit is set on the station whose frequency is 1008 kHz , another two signals from the neighbouring channels can also emerge on its exit.

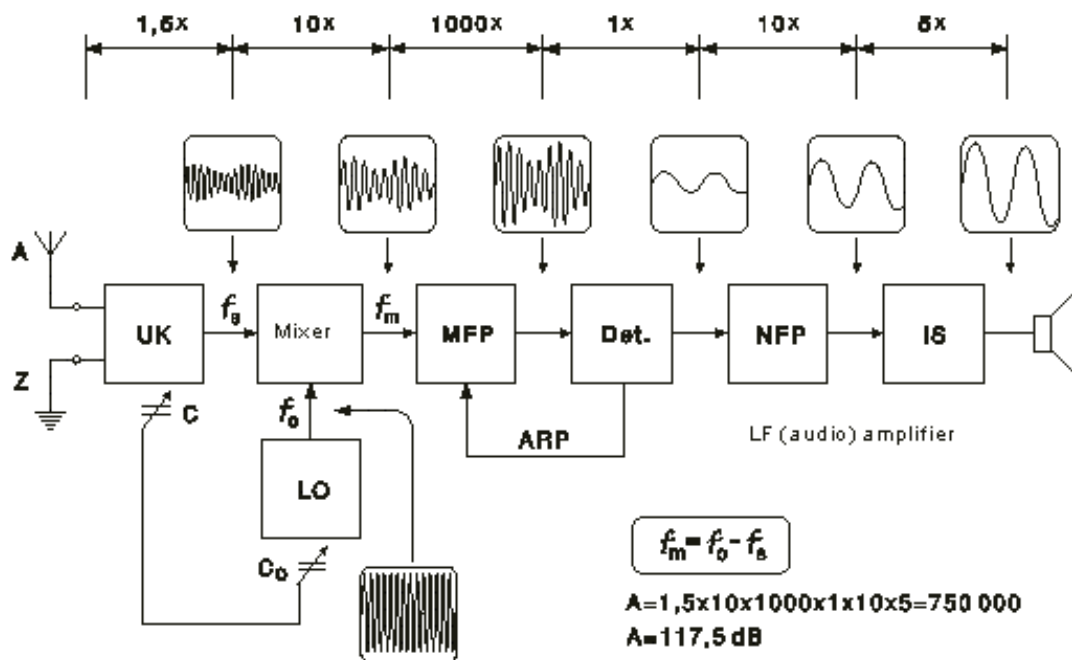

Pic. 4. 1. Block diagram of a superheterodyne AM receiver

Their frequencies would be 999 kHz and 1017 kHz. The ordinary TRF receiver would in this case be totally incapable of suppressing those signals, which is not the case with the superheterodyne receiver. These 3 signals are entering the mixer, which gets the 1463 kHz voltage from the oscillator. The outbreak occurs, and 3 AM signals are exiting the stage, their frequencies being 455 kHz, 464 kHz and 446 kHz. All 3 signals go to the IF amplifier (MFP), which has several amplifying stages with oscillatory circuits set to 455 kHz, making it very selective, so it amplifies only the 455 kHz signal and suppresses the others enough not to disturb the reception.

the signal exiting the IF amplifier is led onto the detector (Det.), the LF voltage amplifier (NFP) and the output stage (IS), the circuits we spoke about in the previous projects.

The ARP signifies the circuit that turns back the DC component of the detected signal into the IF amplifier, to obtain the automatic amplification regulation.

Above every block on the picture you can see the signal shape exiting that block, as seen on the oscilloscope, in case the modulation in the transmitter is done by the single, sinusoidally-shaped tone. The upper part of the picture contains the average voltage amplifications for each block, for the mass-production devices. Total voltage amplification, which is the ratio of the voltage on the loudspeaker to the voltage in the antenna is $A = 750000$. The amplification in decibels is therefore: $A(\text{dB}) = 20 \log A = 117.5$

4.1.1. The Simplest Superheterodyne AM Receiver

The author presumes that most of the readers, especially those just entering the world of radio with this book, are somewhat scared by the block diagram from Pic.4.1. Their question probably is: Can an amateur build such a receiver? Yes, he can. The author has a friend that succeeded in this some 40 years ago, when all had been done with the electronic tubes, making the practical realization of a receiver much harder than it is today, with semiconductors (its radio amateur call sign is YT1FA, and those who doubt it may contact him). However, he was doing this in the premises of YU1EXY Radio Club, in the attic of the Electrotechnical Faculty in Belgrade, using the club (more less trophy) instruments and, more important, he had help of Sasa Piosijan, Radivoje Karakasevic and Kiro Stojcevski, who knew all about the radios, especially Sasa.

The main problem in making a superheterodyne device is not the circuitry complexity but its setup, which requires lot of practical experience and some special instruments, that our readers probably don't possess. But they are much better than the TRF receivers, both regarding the sensitivity and selectivity, so we made simpler devices that are simple to set, with no instruments necessary than your ears. They are realized around the NE612 IC, whose pin description, block diagram and main features are given on Pics.4.2-a & b.

This IC comprises the critical stages of an AM superheterodyne receiver, the mixer and local oscillator. the station signal is led either on pin 1 or on pin 2 (or on both of them, in case of symmetrical coupling with the previous stage), and the IF signal is obtained on the pin 4 or 5 (or on both of them, in case of symmetrical coupling with the next stage). An oscillatory circuit, that determines the frequency of the local oscillator and the positive feedback circuit are connected between the pins No.6 and 7. Pin 3 is connected to Gnd, i.e. the minus pole of the DC supply voltage. Pin 8 receives a positive DC supply voltage which can, acc. to the table given on Pic.4.2, vary between 4.5 V to 8 V. The value of this voltage is not critical, but it is extremely important for normal operation of the receiver that this voltage is stable, therefore urging for it to be

separately stabilized (with special care), as seen in some projects in this chapter and in the Appendix, that involve the NE612.

In the text that follows 3 simple superheterodyne receivers made with NE612 will be described.

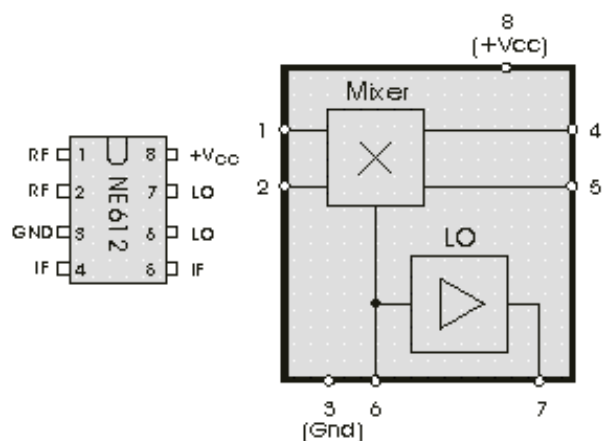

a.

NE612 IC Characteristics (NE602, SA612, SA602)

Parameter	Symbol	Range	Unit
Supply Voltage	V_{CC}	4,5 ... 8	V
Supply Current	I_{CO}	2,4 ... 3	mA
Input resistance (between 1&2 & Gnd)	R_{in}	1,5	k Ω
Output resistance (between 4 & 5 & Gnd)	R_{out}	1,5	k Ω
Mixer amplification	A_{mix}	14 ... 17	dB
Maximum oscillator frequency	f_{omax}	200	MHz
Maximum mixer frequency	f_{mmax}	500	MHz
Outside oscillator voltage	U_o	200	mV

b.

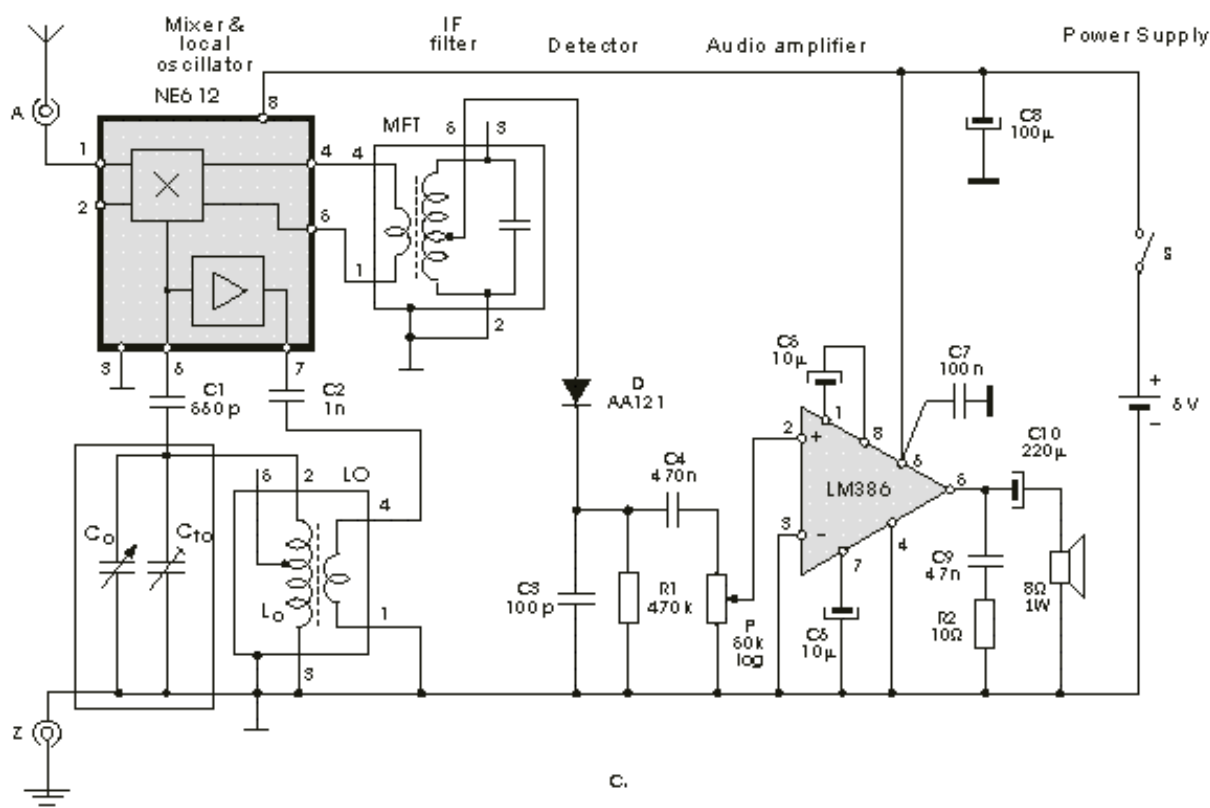

c.

Fig. 4.2. The simplest superheterodyne AM receiver: a-pin layout and block diagram of the NE612, b-IC technical data, c-electronic diagram of the receiver

More will be discussed in the chapter dedicated to NE612 IC, and the reader should pick one of these, or make the receiver that suits him best by combining these diagrams with earlier described HF amplifiers and input circuits.

The electronic diagram of the simplest superheterodyne AM receiver in the world, with reproduction over the loudspeaker, is shown on Pic.4.2-c. The device has got only one oscillatory circuit in the IF amplifier (being marked as MFT), whose frequency does not need to be set to some specific value (meaning the receiver will work OK even if its frequency is bigger or smaller than standard 455 kHz). Further simplification was done by omitting the input circuit, therefore avoiding the problems with quite complex adjustments between the input circuit and the local oscillator. All these simplifications do have their price: this device is less sensitive and selective than the complete superheterodyne, and is also more prone to disturbances. Even so, it has better both the selectivity and sensitivity than the TRF.

Signals of all the stations are being led directly from the antenna onto the pin no.1, i.e. the mixer. On the other hand, the

mixer also receives the HF voltage from the local oscillator, whose frequency is equal to the resonance frequency of the parallel oscillatory circuit made of CO, CtO, and LO. This frequency, if neglecting the parasite capacitances, is:

$$f_o = \frac{1}{2\pi\sqrt{L_o(C_o + C_{tO})}}$$

On the mixer exit the signals from all the stations are obtained, but now they have new carrier frequencies, that are equal to the difference of the oscillator frequency and their original one. Nevertheless, only one of these signals will have the frequency that is equal to the resonance frequency of the MFT, and it will be the only one to appear on the ends of this oscillatory circuit. Here's a numerical example.

Let us assume that we have (only) 3 MW signals in the antenna, having the frequencies of fS1=711 kHz (Nis), fS2=855 kHz (Bucharest) and fS3=1008 kHz (Belgrade 2). The IF transformer frequency could be fm=455 kHz. If we set the frequency of our oscillator on fm=1166 kHz (with CO), the following signals, modulated by the radio stations' programs, will exit the mixer:

$$\begin{aligned} f_{m1} &= f_0 - f_{S1} = 1166 - 711 = 455 \text{ kHz,} \\ f_{m2} &= f_0 - f_{S2} = 1166 - 855 = 311 \text{ kHz and} \\ f_{m3} &= f_0 - f_{S3} = 1166 - 1008 = 158 \text{ kHz.} \end{aligned}$$

Since the oscillatory circuit on the mixer exit (MFT) is set to 455 kHz, we will have Radio Nis's signal from it, others will be suppressed. If we wish to hear Bucharest, the oscillator frequency should be set to 1310 kHz, and for Belgrade 2 1463 kHz. Of course that the listener doesn't need to know all these frequencies, he will just turn the knob of CO until hearing the desired station's broadcast.

The IF signal is led from the pin 3 to the detector with AA121 diode. The LF signal is taken from the R1 resistor and over the capacitor C4 it is led to the volume potentiometer P and the audio amplifier.

* the MFT is also being called the inter-frequency transformer. It is a special type component that is hard to find in the ordinary electronic shops, therefore the radio amateurs are usually obtaining them from disused factory-made devices. The IF transformer is shown on Pics.4.3-a,b,c & d. As you can see it on 4.3-a, the MFT is, in fact, a parallel oscillatory circuit with a leg on its coil. The coil body has a ferrite core (symbolically shown with single upward straight dashed line) that can be moved (with screwdriver), which allows for the setting of the resonance frequency of the circuit, being mostly fm=455 kHz. The same body contains another coil, with less quirks in it. Together with the bigger one it comprises the HF transformer that takes the signal from the oscillatory circuit into the next stage of the receiver. Both the coil and the capacitor C are placed in the square-shaped metal housing that measures 10x10x11 mm (Pic.4.3-b). From the bottom side of the housing you can see 5 pins emerging from the plastic stopper, that link the MFT to the PCB, being connected inside the MFT as on Pic.4.3-a. Besides them, there are also two noses located on the bottom side, that are to be soldered and connected with the device ground. Japanese MFT's have the capacitor C placed in the cavity of the plastic stopper, as shown on Pic.4.3-c. The part of the core that can be moved with the screwdriver can be seen through the eye on the top side of the housing, Pic.4.3-d. This part is coloured in order to distinguish the MFT's between themselves, since there are usually at least 3 of them in an AM receiver. The colours are white, yellow and black (the coil of the local oscillator is also being placed in such housing, but is being painted in red, to distinguish it from the MFT).

Un-soldering the MFT isn't that simple and is to be performed very carefully. The iron is not to be kept leaned too long on the pins, since there's danger of melting the plastic stopper. All the tin from the pins and noses has to be removed first, by the aid of the iron and the vacuum pump (or a piece of wire stripped from the antenna coaxial cable). You can then safely remove the MFT from its original PCB.

* Pics.4.3-a, b, c & d almost fully apply for the oscillator coil as well (LO). The only difference is that LO doesn't have the capacitor C. looking from the outside, LO and MFT can be distinguished only by the marking colour, until they're lifted from the PCB.

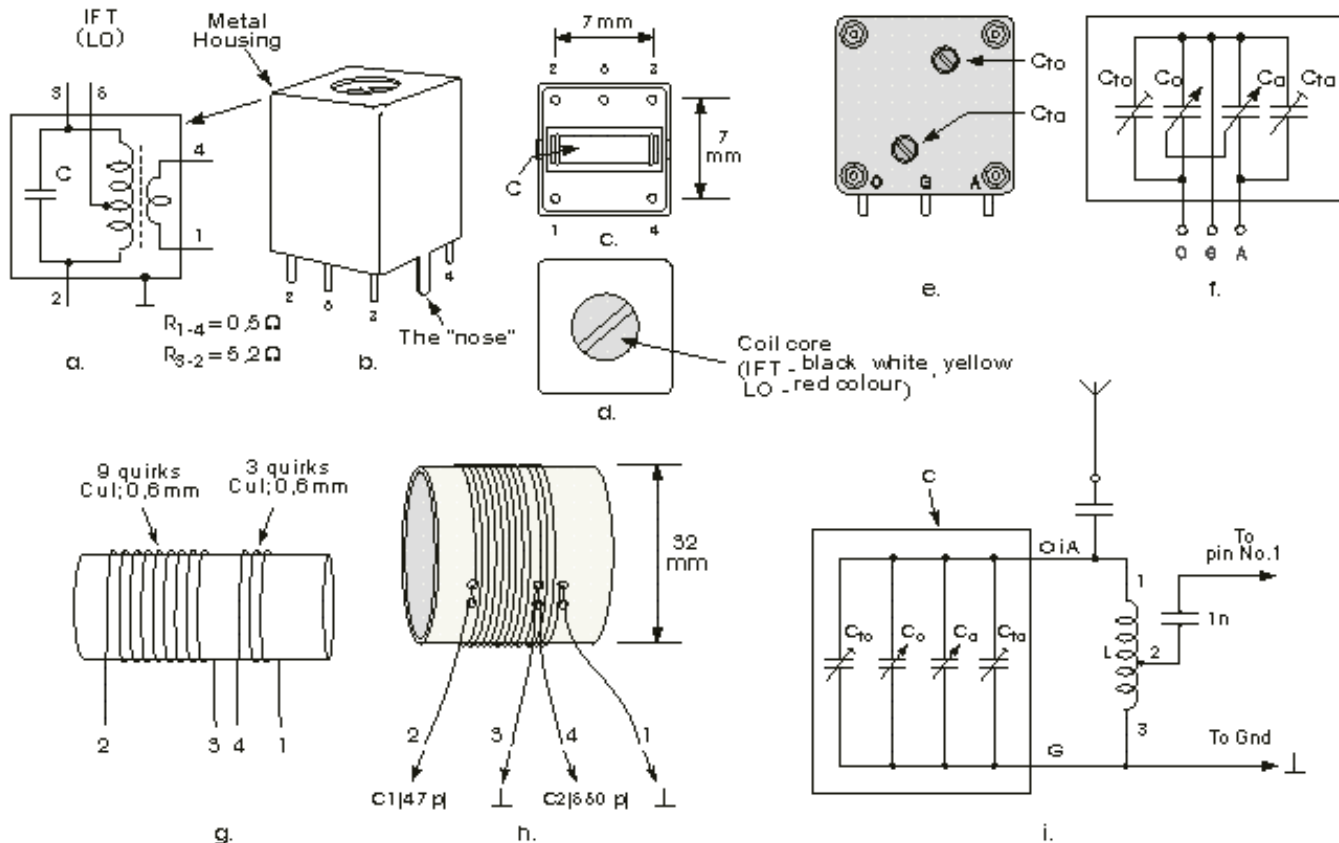

Fig. 4.3. Components of the receiver from pic. 4.2: a, b, c, d-IFT and LO; e, f-variable and trimmer capacitors of the local oscillator, g, h-SW oscillator coil; i-independent input circuit

LO's have red colour, while MFT's (IFT's) are white, black or yellow. During the PCB design, absolute care must be taken that pins 1 & 4, as well as 2 & 3, do not permute. If that would happen, the feedback would be negative (instead of positive) and the oscillator wouldn't function. However, if you conclude during the design phase that it would be more convenient to connect pin 4 to Gnd (instead of pin 1), do have in mind that it can be done only if you connect also pin 2 to Gnd (instead of pin 3).

* Fine tuning (if necessary) of the LO's and MFT's inductance values is done by adjusting the position of the ferrite core with screwdriver.

* With CO and CtO, variable capacitor and the trimmer capacitor in the oscillator are labelled. Acc. to Pic.4.3-e & f, which shows the capacitor we spoke about in the connection with Pic.3.7, the abovementioned capacitors are connected with the circuitry over the legs O and G (Ca and Cta are not used), with G connected to Gnd.

* The receiver from Pic.4.2 can be utilized for the reception of AM stations in the SW waveband. All there is to be done is to make a new oscillator coil, acc. to Pic.4.3-g & h. It is being made of 0.4 mm CuL wire (a thicker one can also be used), on the 32 mm diam. carton body, the same one used for making coils on Pics.3.6 & 3.28. Number of quirks on the picture is 9, but other combinations should also be tried, say, 12 quirks, or somewhat less than 9. The feedback coil has 3 quirks and is spooled along the oscillator coil (as shown on picture), or over it. If you have already accomplished the reception of SW stations with some of the previously described TRF devices, you will be surprised with much bigger selectivity of the receiver from Pic.4.2. In the evening hours you'll be able to perform the receipt of huge number of stations on the radio-broadcast, professional and amateur wavebands.

For the reception of SW stations smaller capacitances for C1 should also be tested, say, C1=33 pF and similar, since it affects the oscillator frequency.

* In the previous numerical example we saw that tuning is done by setting up the frequency of the local oscillator and that

$f_m = 455$ kHz, Radio Nis will be heard when the oscillator frequency is $f_o = 1166$ kHz. The story is not over, though: What will happen if there is a station that operates on 1621 kHz? Mixing its signal with the voltage from the local oscillator the modified signal is made, its frequency being $1621 \text{ kHz} - 1166 \text{ kHz} = 455 \text{ kHz}$.

We now have two signals on the MFT. They both have the same carrier frequency (455 kHz), one of them is program of Radio Nis, and the other comprehends the program of the station transmitting on 1621 kHz. Both of them are being heard in the loudspeaker, the interference occurs. Speaking in expert language, the obstruction because of the symmetrical station occurred. That is a station whose frequency f_{SS} is greater than f_m for the value of the oscillator frequency:

$f_{SS} = f_o + f_m$
 Suppressing the symmetrical station signal must be done before the mixing stage. In the radio-broadcast receivers this is being done over the input circuit, and in the professional devices, by input circuitry and the HF amplifier. If you have experienced disturbances while using the receiver from Pic.4.2 (mixing of stations or, more common, whistling or squeaking tone) try changing the MFT's oscillation frequency (by turning the ferrite coil), then re-tune the receiver.

* If the receiver from Pic.4.2 is power-supplied from the battery (or adaptor) whose voltage is over 6 V, a voltage stabilizer should be inserted in the plus (+) line of the power supply for NE612, as it was done with the receivers on Pics. 4.4, 5.7 and 5.9.

If you cannot receive the signal of some station transmitting on 1500 kHz, not even with the capacitor CO knob in the rightmost position, start reducing the CtO capacitance (turning the trimmer with screwdriver) until you hear the signal. Similarly, if you can't hear some station you're fond of, that transmits on 500 kHz (e.g. Radio Budapest), try increasing the LO inductance (by turning the core towards inside with screwdriver). If this doesn't succeed, change a little the MFT frequency, then try again.

* The reception can be significantly improved if input circuit (UK) is added to the receiver. In order to avoid problems with attuning the UK and the LO, the UK with special variable capacitor can be used, as on Pic.4.3-i. It is "our" capacitor from Pic.3.7, with all the capacitors connected in parallel, and "our" coil from Pic.3.6. Station tuning is now being done with two buttons, which isn't "a job for everyone". The receiver is first roughly tuned to the station using these two buttons, and then the optimum reception is carefully searched.

* If you omit the amplifier with 386 IC on the Pic.4.2, and connect high-resistance headphones instead of R1, it is the truly the simplest superheterodyne receiver in the world.

4.1.2. The Fully (not exactly 100%) Superheterodyne AM Receiver No.1

Its electrical diagram is given on Pic.4.4. It is easily being noticed that this is the receiver from Pic.4.2 with inter-frequency (IF) amplifier with ZN415E added.

By adding ZN415 IC multiple enhancements are performed. Thanks to its huge input resistance, the MFT's oscillatory circuit is not choked, resulting in better selectivity. The sensitivity of the device is extremely increased since this IC has big amplification and the AAR (automatic amplification regulation) is also accomplished, making the usage of this device easier and more comfortable.

* It is very important to obtain the necessary value of the DC voltage in pin 6 of the ZN415 for its proper operation. Acc. to the table on Pic.3.36 it has to be about 1.3 V, and its setting is done via the TP1 trimmer. The receiver is set to some weaker station, the sound volume is made very low with potentiometer P, and the slider of the TP1 is carefully moved until the best reception is made. If that doesn't work, one should try changing the value of R5 resistor; this is to be done also if the supply voltage being used is other than 12 V. In case of voltage on the pin being much bigger than 1.3 V, and cannot be reduced on the trimmer, short-circuit one of the diodes.

* The voltage stabilizer with 78L06 isn't needed if the receiver is supplied from the 6 V battery.

* The receiver from Pic.4.2 needs input circuit to be 100% complete. That can be an independent input circuit from Pic.4.3-i, or input circuit and the HF amplifier that are described in the Appendix (Pic.5.10). If the former circuit is used, station tuning is being accomplished with 2 knobs, as explained in the previous chapter.

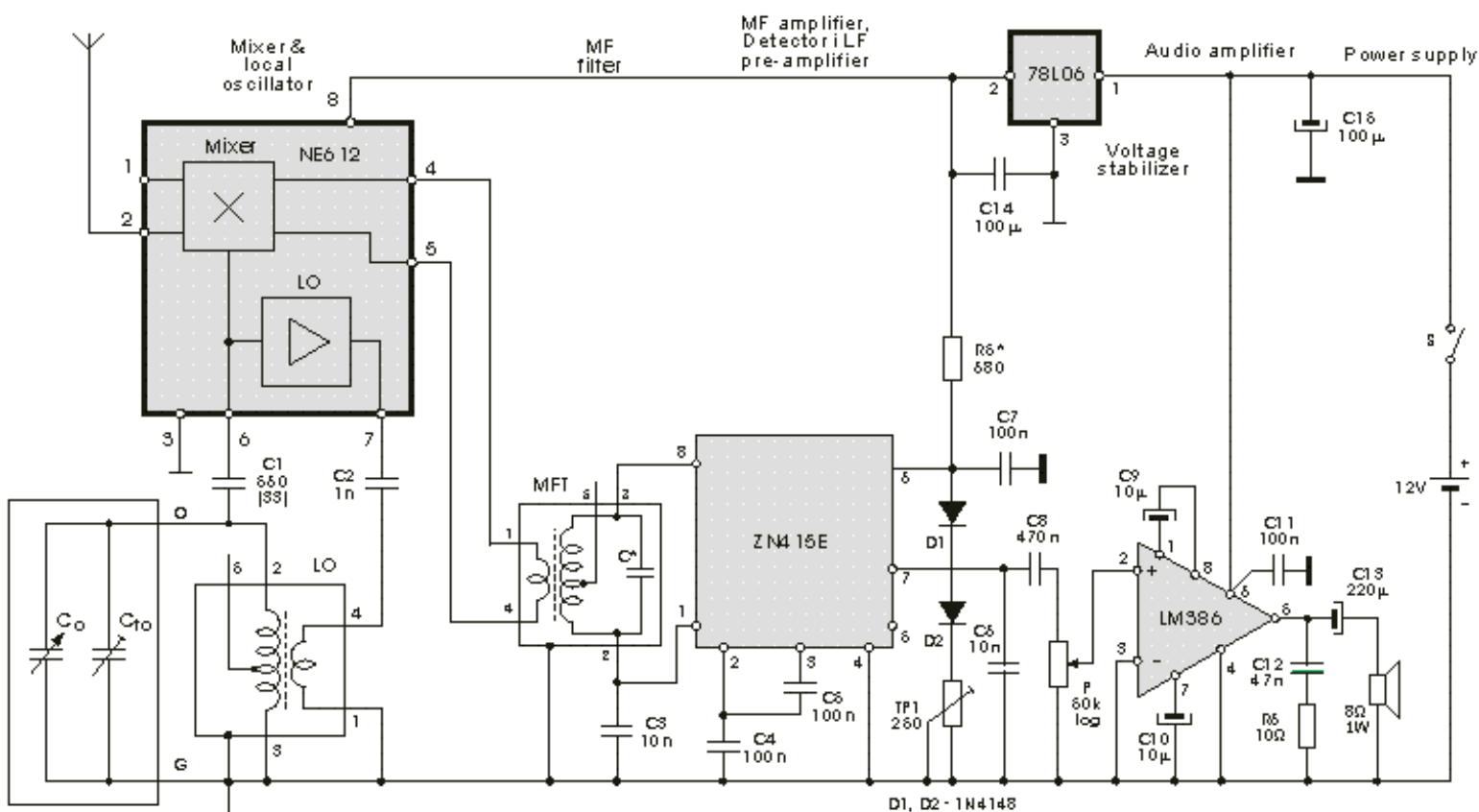

Pic.4.4. Superheterodyne AM receiver with NE612, ZN415E & LM386

4.1.3. Fully (not exactly 100%) Superheterodyne AM Receiver No.2

All the receivers we made with NE612 IC were tested in our lab, except the one from the previous project, since we didn't have ZN415 "with us". We found, however, a ZN414 IC, so we tested the receiver from Pic.4.5 with it. The receiver was working great, from the amateur's point of view. He played us for long time, until we didn't require the board to test one of the receivers from previous projects afterwards, when we regretfully had to disassemble it.

* The diagram is very similar to that on Pic.4.4, so most of the things said about that receivers stands for this one, too.

* DC voltage setting on pin 1 of ZN414 is done with the trimmer TP. Its slider is put in mid position, the receiver is tuned to some weaker station close to the upper bound of the bandwidth. While making the reproduction very quiet (slider of P as low as possible), the trimmer slider is moved until reaching optimum reception. After that the trimmer is disconnected, its

resistance measured and the ordinary resistor of similar value is put into circuit.

* The device operates nicely with the outside antenna made of a piece of wire measuring only half metres in length.

* The reception would certainly become better if an input circuit would be added, which we spoke about in the previous project.

* The receivers from pics. 4.4 and 4.5 can, with appropriate coils in the oscillator, accomplish the reception of AM stations from all the bandwidths from 70 kHz till 200 MHz.

4.2. Superheterodyne FM Receivers

The FM receivers being described in chapter 3.15 are the amateur solutions. These are extremely simple devices, that cannot perform the noiseless tuning, automatic oscillator frequency regulation and other features that ensure very high quality of the reproduction, being expected from an UHF FM receiver. The true solution is the superheterodyne FM receiver, whose block-diagram is given on Pic.4.6.

Station signals are taken from the dipole antenna and led through the appropriate cable into the input circuit (UK). Inside it, the signal selection is performed, of station whose frequency is f_s , this signal is then amplified in the HF amplifier and led into the mixer. As in the case of earlier described AM receiver, the inter-frequency signal is obtained at the mixer output, whose carrier frequency is $f_m = 10.7$ MHz (this is the standard value, used in all radio-broadcast FM receivers). The IF signal is being amplified in the IF amplifier and led on the amplitude limiter (Ogr.). In this stage the signal whose amplitude exceeds certain level is being cut off, accomplishing with this the elimination of the parasite amplitude modulation, which is performed by various noise sources during the transmission (atmospheric charges, various electrical devices etc.), which significantly improves the signal quality. The signal then goes to the FM signal detector, where the information being modulated in the transmitter is extrapolated from the signal, followed by the LF part of the receiver. With AFC the circuit that performs the automatic frequency regulation of the local oscillator is labelled.

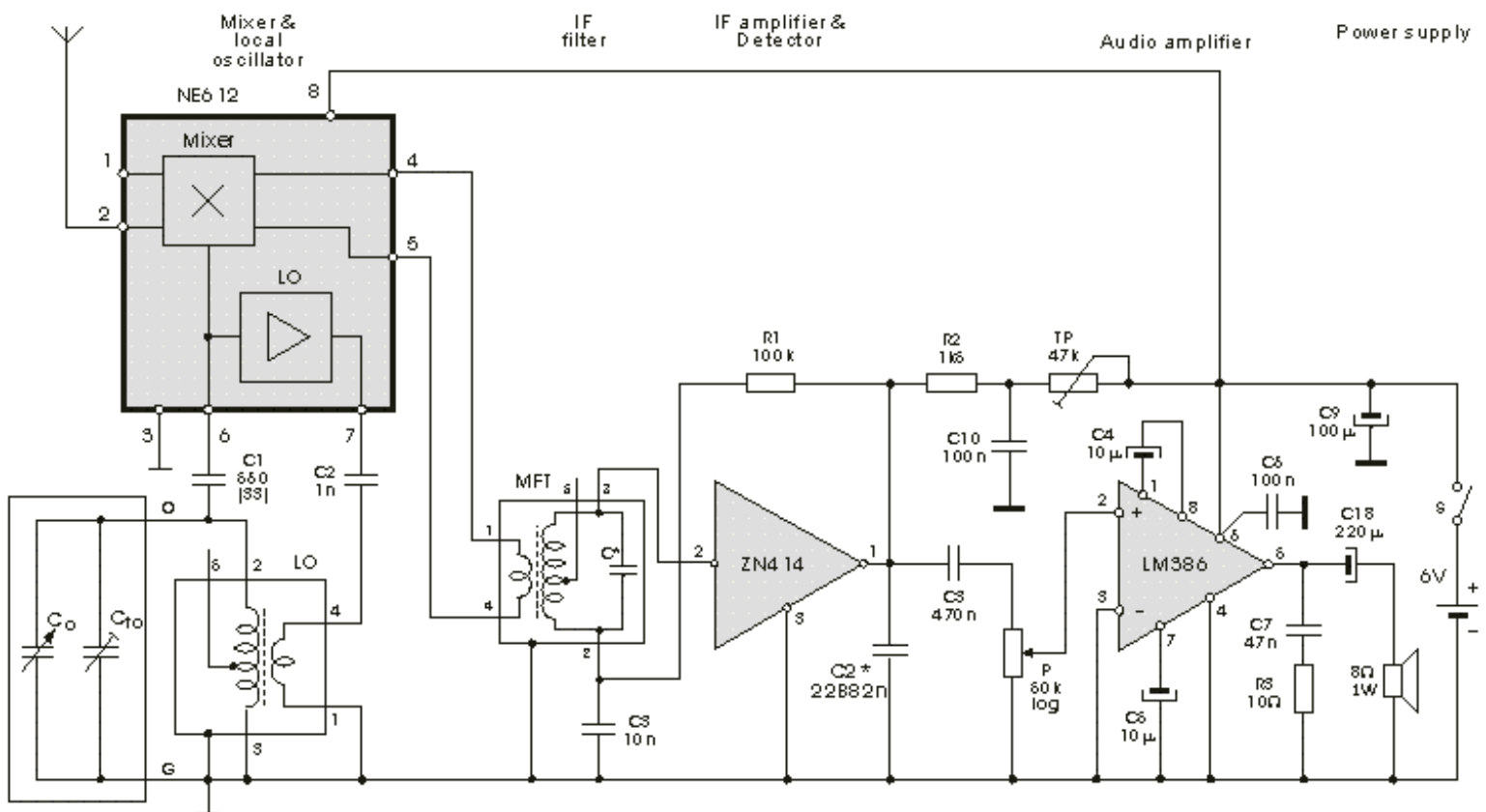

Pic. 4.5. Superheterodyne AM receiver with NE612, ZN414 & LM386

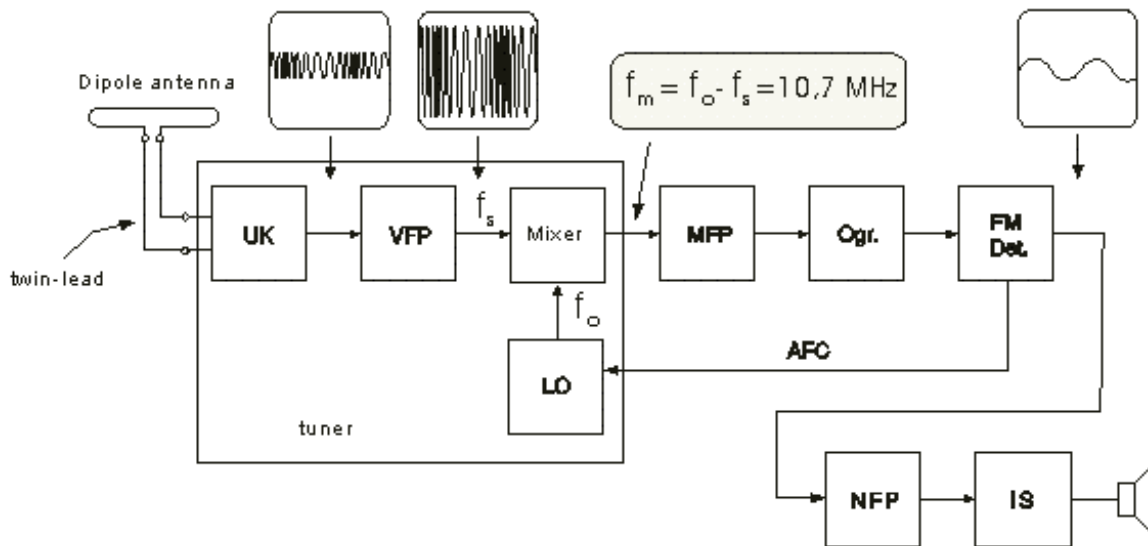

Pic. 4.6. Block diagram of the monophonic superheterodyne FM receiver

4.2.1. FM Receiver with TDA7000

The fact that FM receivers operate on pretty high frequencies makes their practical realization somewhat difficult, but most of the problems, as in many other amateur builds, originates from building the coils, except the self-bearing, small-inductance coils (without the coil body), which are easy to make, especially if there aren't many of them in the device and if no special instruments are required for setting up their proper inductance value. The coils used in this FM receiver are just like this, and there are only two of them, making the practical realization much easier.

The basic data about the famous Philips' IC used in this project, TDA7000, are given in the following table.

Supply Voltage	$2,7 \div 10$	V
Current Consumption ($U_s=4,5V$)	8	mA
Frequency Bandwidth	$1,5 \div 100$	MHz
Sensitivity	1,5	mV
LF signal on pin 2	75	mV
Package - DIL-18 ;SOT102-1	-	-

Electronic diagram of the HF part of the device (from antenna to the LF output) built with TDA7000 is shown on Pic.4.7. As one can see, it is a simple device, made with relatively small number of components. The IC contains all the stages of the superheterodyne receiver: the mixer, the oscillator, the IF amplifier, the amplitude limiter, the FM detector and few others. More about them will be told in the next project which contains the description for a receiver with TDA7088T IC, which is the improved version of TDA7000.

The station signal is from the (telescopic) antenna led to the input circuit that consists of L2, C13, C12 and C14. It is a parallel oscillatory circuit damped with R3 resistor, which has the reception bandwidth from 88 MHz till 108 MHz (it admits all the UHF signals on the pin 13, and weakens the signals outside the reception bandwidth). Inside the IC the signals are led into the mixer, where they are being given new carrier frequencies. The IF amplifier then follows, amplifying only one of those signals, the one whose frequency is equal to the inter-frequency, followed by the limiter, the FM detector, mute circuit and LF pre-amplifier. The output from the last stage is on the pin 2 (R2 is the collector load of the last transistor in the LF pre-amplifier). The oscillatory circuit of the local oscillator (L1, Cp, Cs, C and C5) is connected between pins 5 and 6.

Pic.4.8-a shows the PCB of the device from Pic.4.7, while Pic.4.8-b contains the component layout (on the PCB). The complete device can be seen on Pic.4.8-c. The variable capacitor from Pic.3.8 is used as the only variable capacitor here since the input circuit is aperiodic, the legs marked with FO and G. This capacitor serves us to tune the receiver to stations. In the LF part of the receiver, the amplifier made with LM386 from Pic.3.19 is utilized (the components left from the potentiometer are omitted).

* L1 and L2 are the self-bearing coils (without the core). They have few quirks and are made of relatively thick wire, therefore they don't need a body of any kind, that is why they are called "self-bearing". Their appearance is shown on Pic.4.9, and the calculus for them is done acc. to the table from Pic.3.5. They both have 6 turns of the CuL wire, 0.6 mm in diameter, being

spooled on the flat part of the 3 mm drill. In order to be able to solder the coil onto the PCB, the couple of mm of isolation has to be removed from the wire ends with sharp knife, and they have to be tinned afterwards. There must be a small gap between the adjacent quirks. The inductance of the coil is set by its shrinking (the inductance increases) or stretching (the inductance decreases). Stretching can be nicely done by inserting the screwdriver between the quirks and then turning it along the coil.

* The TDA7000 also contains the mute circuit (for noiseless tuning). It is being active when the S2 switch is open. Pocket-type receivers usually do not have S2 and R1 elements.

* The part of the receiver that requires biggest care during build is the oscillatory circuit of the local oscillator, which is connected between the pins 5 and 6. When changing the capacitance of C, its resonance frequency must change from 88 MHz ($C=C_{max}$) till 108 MHz ($C=C_{min}$). If that cannot be accomplished (not all the stations can be heard) some experimenting is required with capacitances of Cp and Cs. For start, you should omit the Cp. If the problem persists,

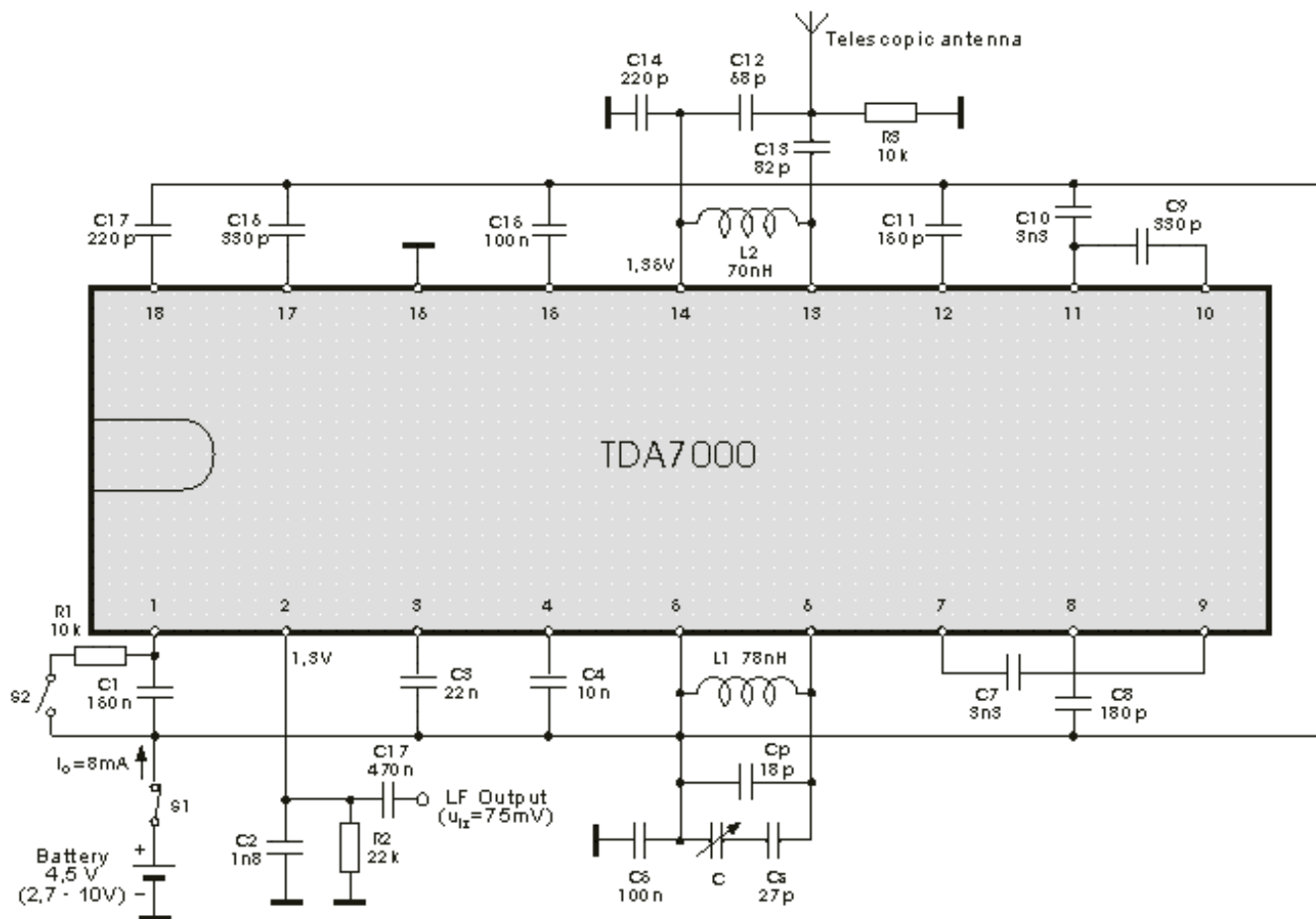

Pic. 4.7. FM radio receiver with TDA7000

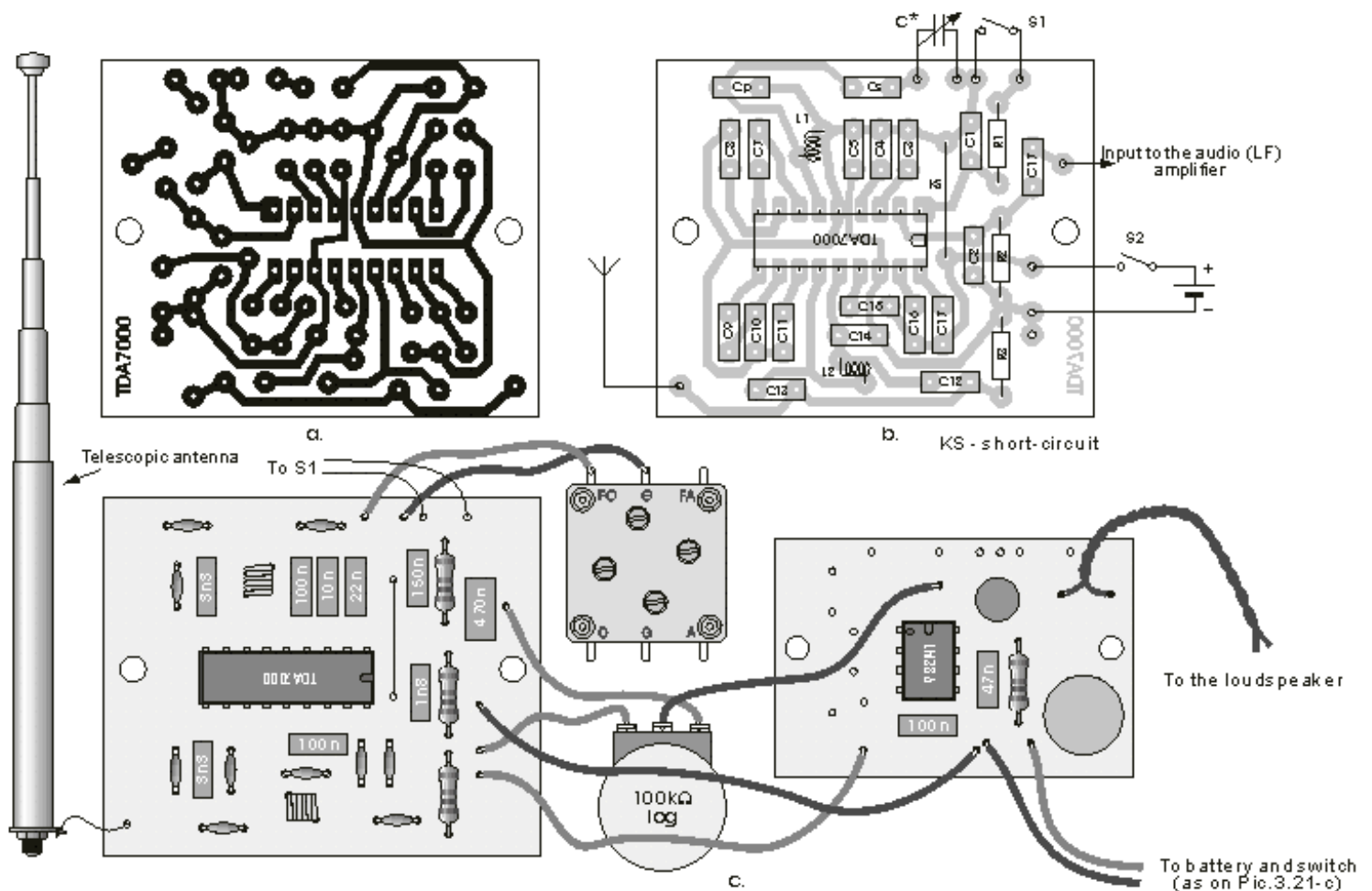
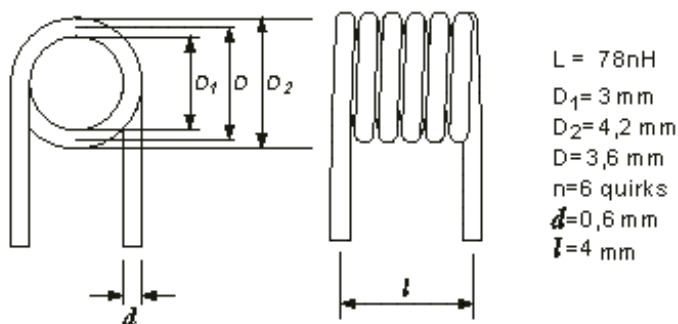

Fig. 4.8 Practical realization of the receiver from Pic. 4.7: a-PCB, b-component layout, c-complete device

capacitance of C_s should be reduced (to 15 pF, 10 pF etc.), or it should be short-circuited. You can also try compressing or stretching the L1 coil, etc. The setup of the oscillatory circuit is completed when with $C=C_{max}$ some station that operates on app. 88 MHz can be heard, and with $C=C_{min}$ the one that works on 108 MHz.

The input circuit setup (it is connected between pins 13 and 14), is performed by tuning the receiver to some mid-range station (about 98 MHz). Then, the best possible reception is searched, by changing capacitances C13 and C12 and inductance L2.



$L = 78\text{nH}$
 $D_1 = 3\text{ mm}$
 $D_2 = 4,2\text{ mm}$
 $D = 3,6\text{ mm}$
 $n = 6\text{ quorks}$
 $d = 0,6\text{ mm}$
 $l = 4\text{ mm}$

Fig. 4.9. Coils for the receiver from Pic. 4.7

4.2.2. FM Receiver with TDA7088T IC

The receiver described in the last project has two IC's, one variable capacitor, two small coils and fairly small few other components, so it can be put into some small box, by carefully placing the components. Further miniaturization can be accomplished by using the SMD components. These are the resistors, capacitors, transistors, IC's and other components, whose dimensions are significantly smaller than these of "classical" components. They are mounted on the copper side of the PCB, therefore it isn't necessary to drill the holes on the board. TDA7088T is also an SMD component. Its drawing is shown on

Pic. 4. 10.

This IC is the successor of the famous TDA7000, i.e. it is an improved model of TDA7000, that allows to implement both monophonic and stereophonic FM receiver. The basic features of TDA7088T are given in the following table.

Supply Voltage	$1,8 \div 5$	V
Consumption current ($U_e=4,5V$)	$4,2 \div 6,6$	mA
Frequency bandwidth	$0,5 \div 110$	MHz
Sensitivity	3	mV
LF signal on pin 2	85	mV
Package - DIL-18 ;SOT102-1	-	-

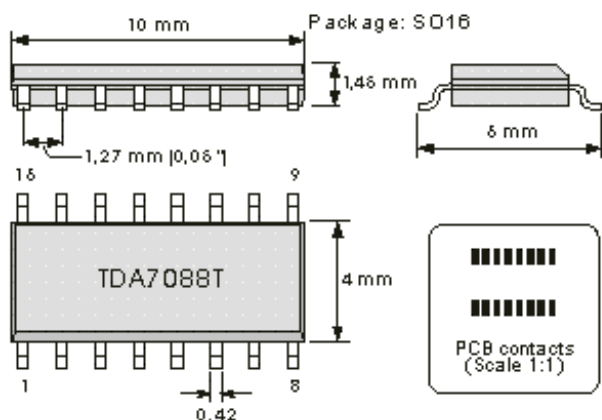

Pic. 4. 10. TDA7088T IC Layout

The electronic diagram of the HF part of the monophonic FM receiver made with TDA7088T IC is given on Pic.4.11. The IC contains all the parts of the classic superheterodyne receiver: the local oscillator, IF amplifier and FM detector, but also some other circuits that extend the possibilities and improve the features of this IC.

As far as practical use is concerned, the most significant novelty is the auto-tuning circuitry. No variable capacitor is necessary for tuning, as it was in all the previous projects, the BB910 varicap diode is used instead. Its capacitance is being changed by varying the DC voltage supplied to its anode over the 5k6 resistor. This is how the tuning is performed: When the user press and releases the pushbutton marked with "RUN", the positive voltage impulse is released to the S(et) input of the SEARCH TUNING circuit. The 100 nF capacitor then starts charging and the voltage on the pin 16 increases. This voltage is then transferred, over the 5k6, to the anode of the BB910, causing its capacitance to decrease, which increases the frequency of the local oscillator (VCO). The VCO voltage is led into the mixer (MIXER) which also receives, over pin 11, the signals of all the other FM stations. The mixer outputs the FM signals whose frequencies are equal to the differences of the oscillator and the original station frequency. The only signal that can reach the demodulator (FM detector) is the one whose carrier frequency is equal to the inter-frequency, i.e. $f_m = 73$ kHz (selectivity is being accomplished by two active filters whose components are the capacitors connected to pins 6, 7, 8, 9 and 10). Therefore, the oscillator frequency increases until it gets the condition $f_0 - f_S = 73$ kHz is accomplished. When this happens, the charging of the capacitor is halted by the command that is sent into the SEARCH TUNING circuit by two detectors (diode-blocks) located in the MUTE circuit. The AFC (Automatic Frequency Control) circuit now gets its role and prevents the voltage on pin 16 to be changed, until the RUN button is pushed again (this voltage can vary from 0 V til 1.8 V during the tuning).

When the RESET button is pushed, the 100 nF capacitor is discharged, the voltage on pin 16 drops down to zero, and the receiver is set to the low end of the reception bandwidth, i.e. 88 MHz.

Let us get back to the mixer. On its output, the 73 kHz FM signal is obtained, and it is modulated by the programme of the first station that is found after the RUN button is pushed. This signal then passes the active filters, gets amplified in the IF amplifier (IF LIMITER) and passed onto the input of the demodulator. By connecting the demodulator exit, over the LOOP FILTER, the adder (+) and resistor, to the VCO, the so-called FFL (Frequency Feedback Loop) circuit is accomplished, reducing the deviations of the signal being received from ± 75 kHz to ± 15 kHz.

The LF (AF) signal is led from the demodulator, over the LOOP FILTER stage, the inverter (-1) and MUTE circuit onto the pin 2. The detectors (diode-blocks) control the operation of the MUTE circuit, preventing the LF (AF) signal to reach the output pin (2) until the tuning on the station that creates the signal in the antenna that is strong enough for quality reception is obtained.

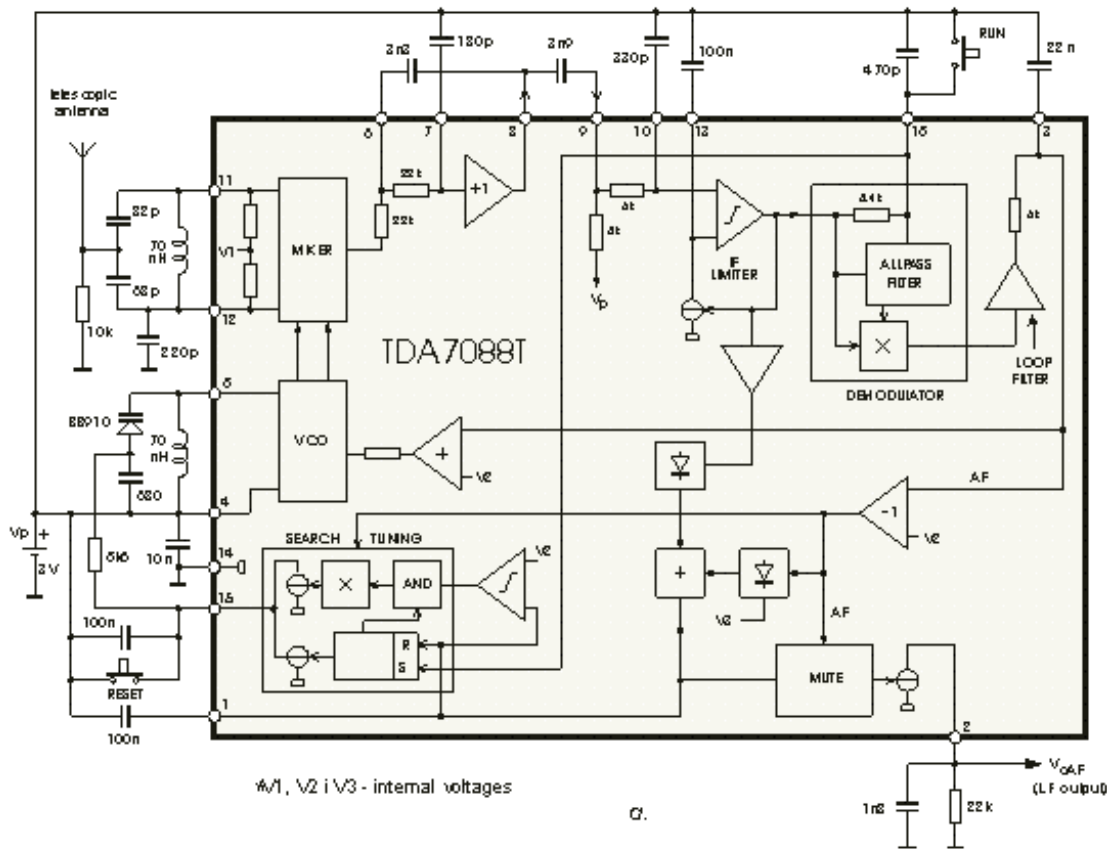

Fig. 4.11. TDA7088T: a- block diagram, b- pin layout

MUTE - output from the circuit for noiseless tuning

V_{OAF} - output LF signal

LOOP - AF LOOP FILTER output

V_p - positive end of the battery (+3V)

OSC - connection to the oscillatory circuit

IFFB - feedback

C_{LP1} - 180pF - LF filter capacitor

V_{OIF} - output from +1 dB amplifier

V_{IF} - input to IF amplifier

C_{LP2} - 330pF LF filter capacitor

V_{IRF} - mixer input

C_{LM} - capacitor of the limiter offset voltage

GND - ground, minus battery pole (0V)

C_{AP} - 47pF capacitor of the ALLPASS FILTER;

input to the SEARCH TUNING circuit

TUNE - electronic tuning; AFC output

4.2.2.1 Mini FM Receiver

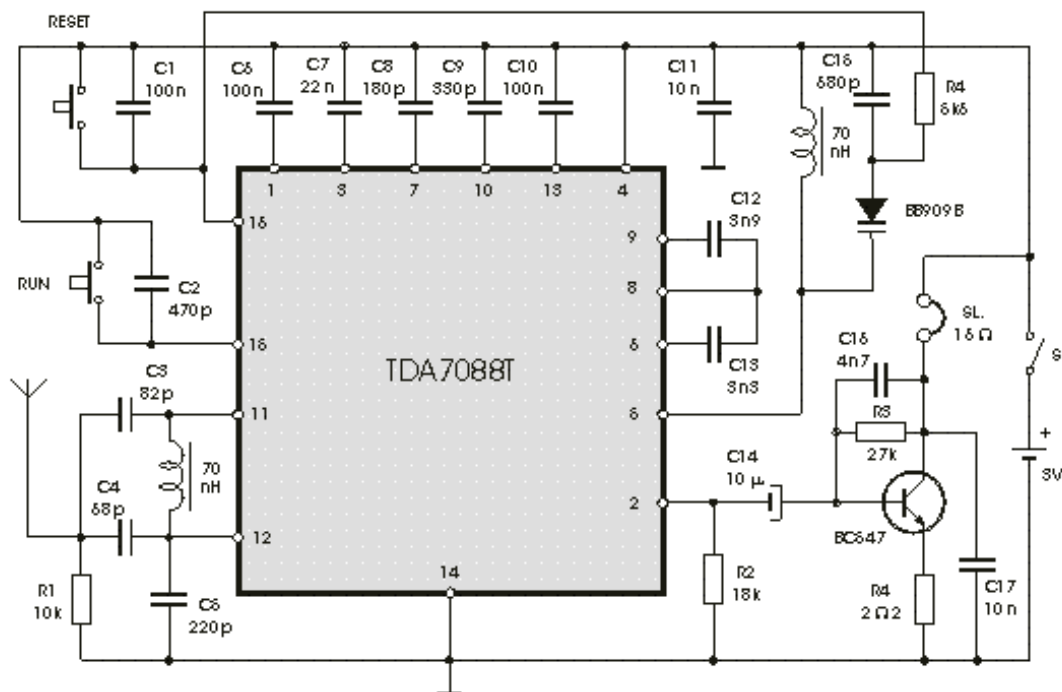

Pic.4.12. Electronic diagram of the monophonic FM radio receiver with electronic tuning

The electronic diagram of the monophonic FM receiver made with TDA7088T is shown on Pic.4.12. If built with SMD components it can be placed in a matchbox, altogether with two button-type batteries. The operating principle of this device is given in the previous chapter. The only thing new is a very simple audio amplifier made with BC547 transistor, which is loaded by cheap 16-Ohm headphones. The telescopic antenna is used, as on Pic.4.8.

Small mishap of this receiver is that it has no indication of station tuning. This problem can be solved by adding a small voltmeter in parallel to the BB909, whose scale is graduated in MHz, as described in the Appendix. This solution is not appropriate for the miniature receiver, since the voltmeter that has the scale that is big enough takes too much space. It is in this case better using a manual tuning instead of automatic. Such solution is given on Pic.4.13.

The tuning is done via the variable capacitor C with numbers written on its button, similar to that on Pic.3.11. It is most simple to use numbers from 1 to 10. The variable capacitor is like the one on Pic.4.8. Some experimenting is to be done with capacitances of C_x and C_y , in order to cover the entire reception bandwidth, from 88 till 108 MHz.

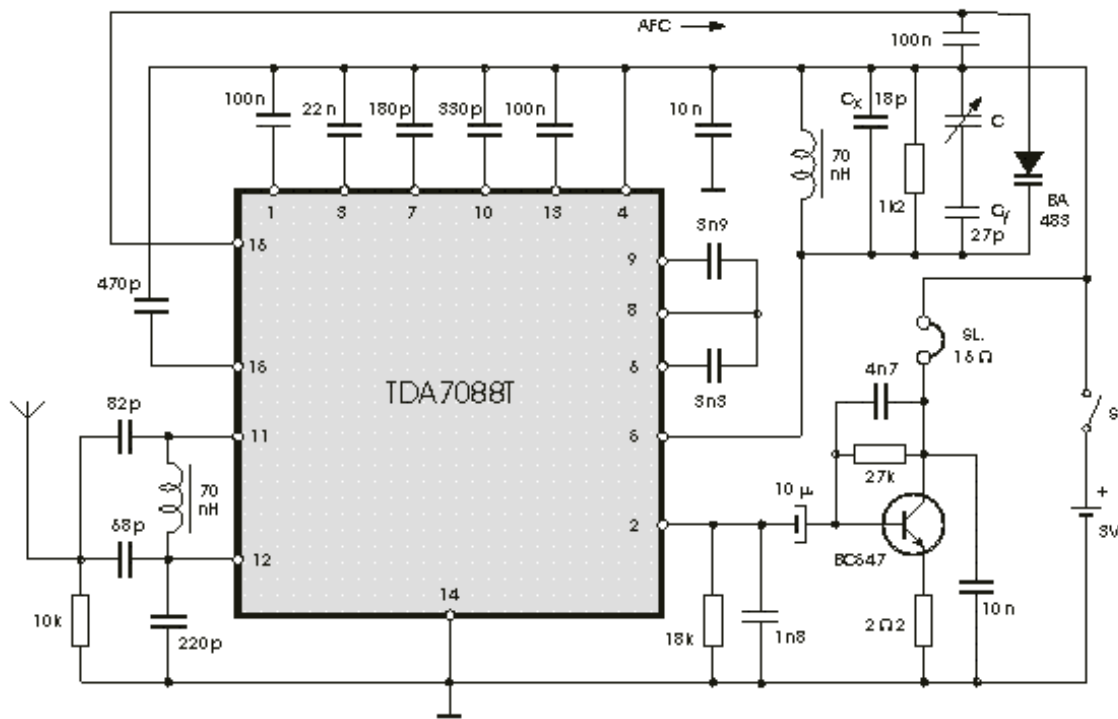

Pic.4.13. Electronic diagram of the monophonic FM radio receiver with manual tuning

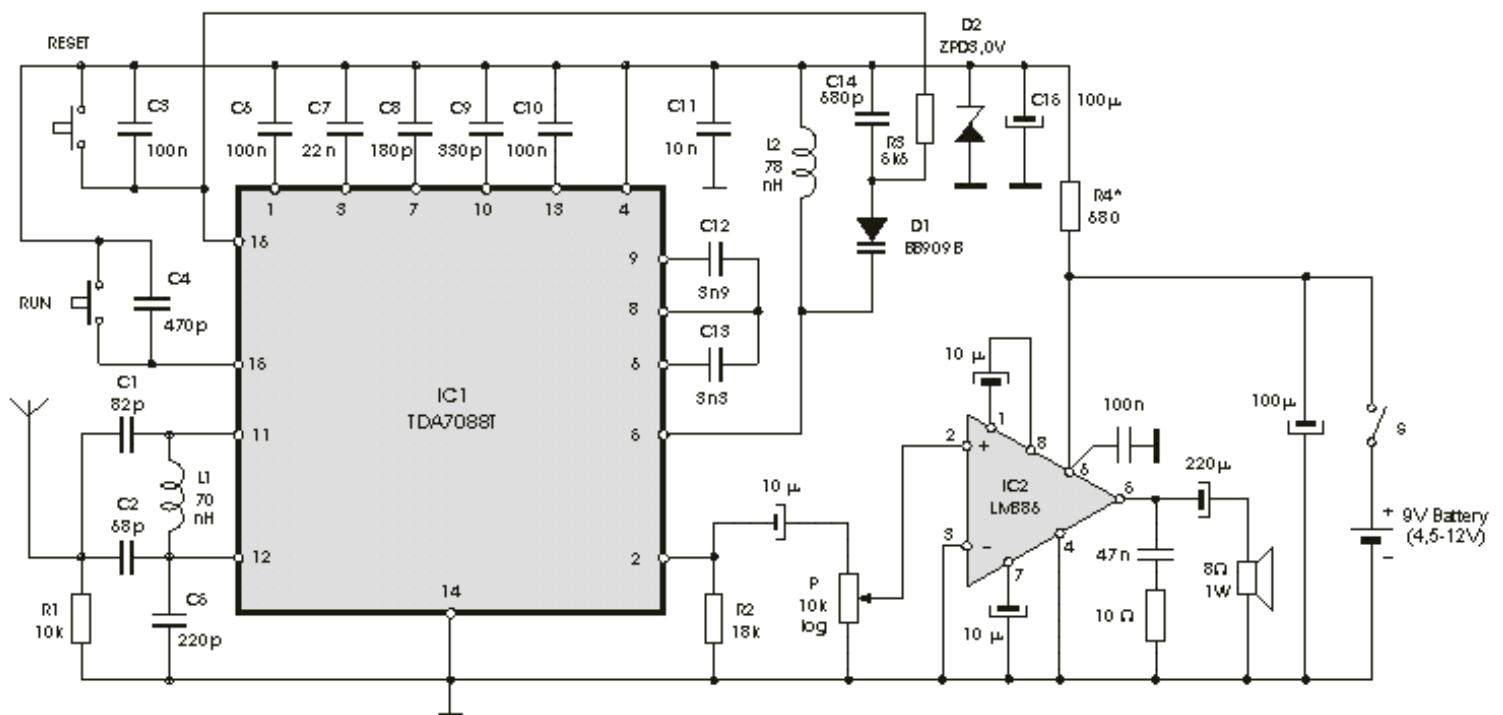

Pic.4.14. Electronic diagram of the monophonic FM radio receiver with TDA7088T and LM386

The AFC (Automatic Frequency Control) of the local oscillator is accomplished with BA483 diode, obtaining that station's position on scale does not "walk" over the scale.

The complete radio receiver should still have a loudspeaker. Electronic diagram of such receiver made with TDA7088T is given on Pic.4.14. As one can see, that is a receiver from Pic.4.12 with an audio receiver made with LM386 IC.

Maximum value of the DC supply voltage for the TDA7088T is 5V, therefore if using a 4.5 V battery the LM386 will work with reduced output power, the D2 diode and C15 capacitor should be omitted, and R4 should be short-circuited.

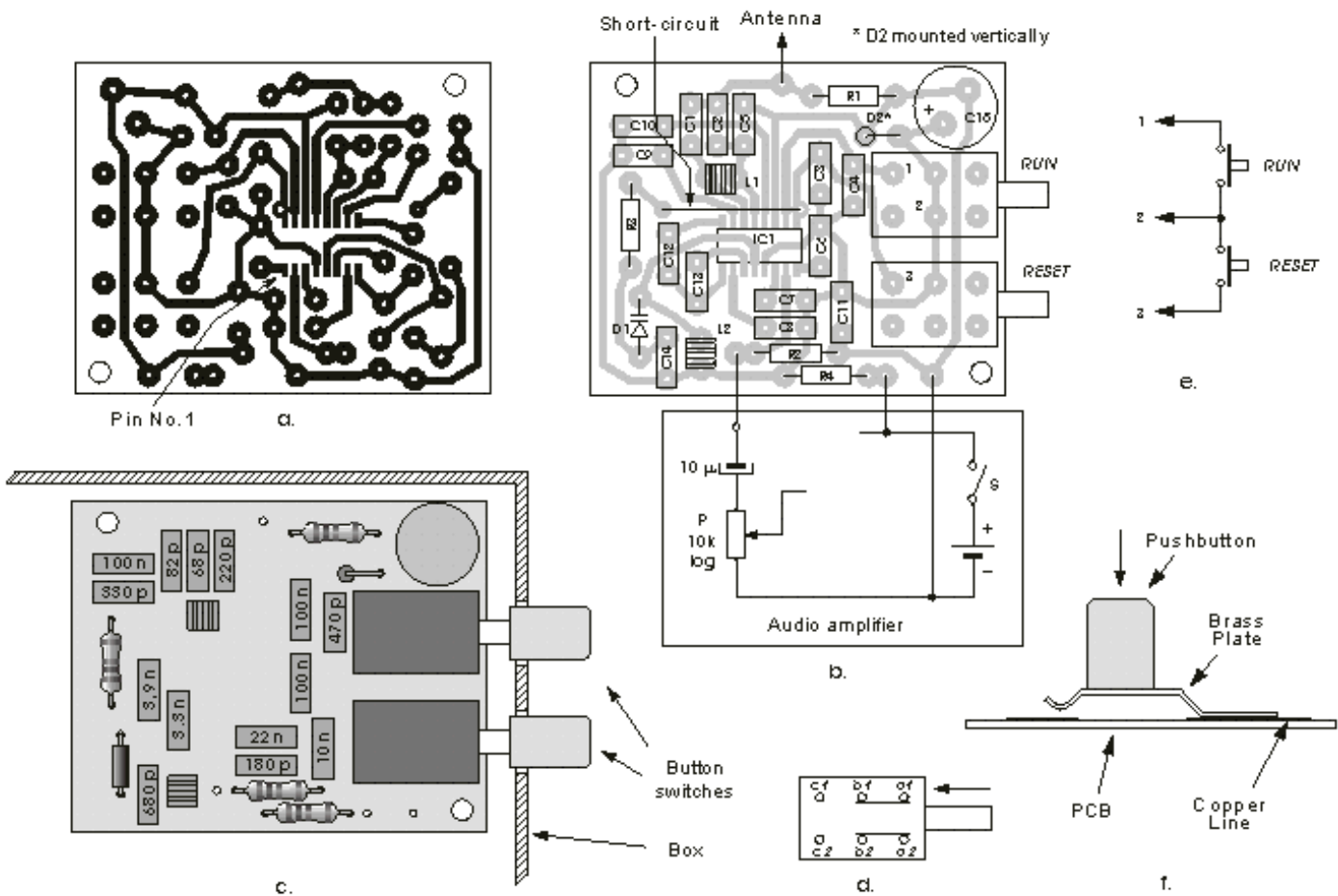

Fig. 4.15. Practical realization of the receiver from Pic. 4.14.: a- PCB copper side, b- PCB component side, c- board layout with components, d- switch for PCB mounting, e- connecting the switches that are mounted on the device box

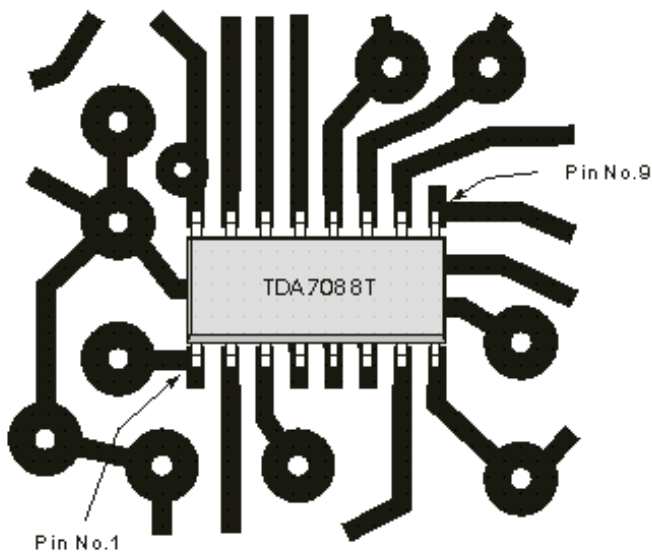
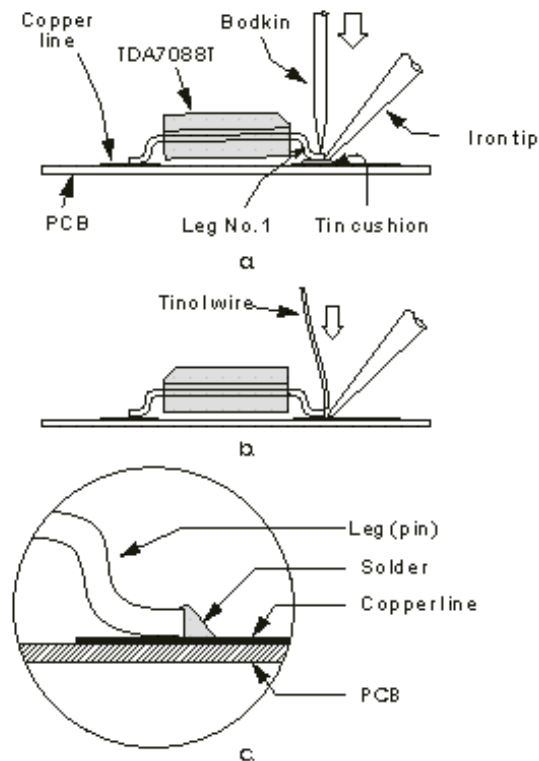

Fig. 4.16. Position of the TDA7088T on the PCB

If higher voltage battery is used, the voltage stabilizer, comprised by the aforementioned components, has to be activated. D2 is a Zener diode with 3 V Zener voltage. The optimum value of R4 is found experimentally: in order to make the power consumption as low as possible it should have the resistance as big as possible, while simultaneously keeping the voltage on Pin 4 about 3 V and the device working well within the entire reception bandwidth (One should start with, say, R4= 1.5 kOhm, and if the receiver operates well bigger resistance should be tried out, and if not smaller one, until the optimum value is found).

Pic.4.15. shows the PCB for the HF part of the receiver with TDA7088T, that is realized with ordinary components, instead of the SMD's. Pic.4.15-a shows the board layout from the soldering (copper) side. All the components apart from TDA7088T are mounted on the opposite side of the board, their pins are put through the holes and soldered through the holes. The TDA is soldered on the copper side, directly onto the copper contacts. That is why it is being drawn in dashed line on pic.4.15-b, where the board layout on the component side is given.

* Pic.4.16-a shows 3x enlarged picture of the IC and the surrounding lines. The soldering procedure for SMD is as follows: A thin tin layer is applied on the copper contacts where IC legs are to be soldered to. The first legs to be soldered are the diagonally opposite ones, in this case No.1 and 9. A small cushion-shaped amount of tin (not profuse) is applied on the contacts where these pins are to be soldered (pic.4.17-a). The IC is placed in its position, with all the pins properly laid. Pin No.1 is pressed against the tin pillow with a top of a bodkin, with iron head simultaneously touching both the tin and the pin end. The tin gets melted, and the pin lies down on its place with the aid of the bodkin, and gets soldered. It is now time to check out the positioning of the chip. If it needs to be corrected, the tin surrounding the pin No.1 is melted with iron tip and the chip position is quickly and carefully adjusted, in order not to overheat the pin. Soldering the pin No.9 is shown on Pic.4.17-b. First, the iron tip is simultaneously put on the top of the leg and the copper below it, so that both of them are heated. After app. half a second, the iron is slightly removed from the leg but remains on the copper contact. The tip of the tinol wire is then approached to touch the iron, the pin top and the copper contact at the same time. The wire gets melted and adheres to the copper and the pin, so it has to be constantly moved downwards. When enough tin is applied, the tinol wire is removed first, then the iron, and the pin No.9 is soldered. Once again you have to check whether all the pins are properly placed, and then they too are soldered as it was just described. The solders are OK if they look app. as on Pic.4.17-c.



Pic.4.17. Soldering of the leg of TDA7088T: a-soldering the leg No.1, b-soldering the leg No.9, c-proper solder look

* Pic.4.15-b contains the PCB component side layout. The pushbuttons we used here are Siemens, type BO2AMAP-2. The common housing contains, as one can see, two button switches, one of which is being used by this device. Any other pushbutton switches can also be used. In that case small modifications on the PCB lines would probably be necessary. The board is mounted fairly close to the box edge, so that the switch shafts are passing through the panel, and that the buttons can be mounted on the outside. The panel-mount switches can also be used, in which case they are connected to the board by wires (pic.4.15-e).

* Any audio amplifier described so far can be used, e.g. the one with LM386, as on pic.4.8.

* Instead of the antenna, a 20 cm piece of wire can also be utilized.

4.2.2.2. Stereophonic Receiver Built with TDA7088T

Stereophonic radio broadcast is performed in the ultra short waveband, from 88 MHz till 108 MHz. All radio transmitters operating in this range are stereophonic, but their signal is designed so that monophonic receivers can also read it, performing the compatibility. The readers that wish to get acquainted in more details with the stereophonic broadcast basics can refer to the "Radio Receivers" textbook, for the IV grade of the Electrotechnical Highschool.

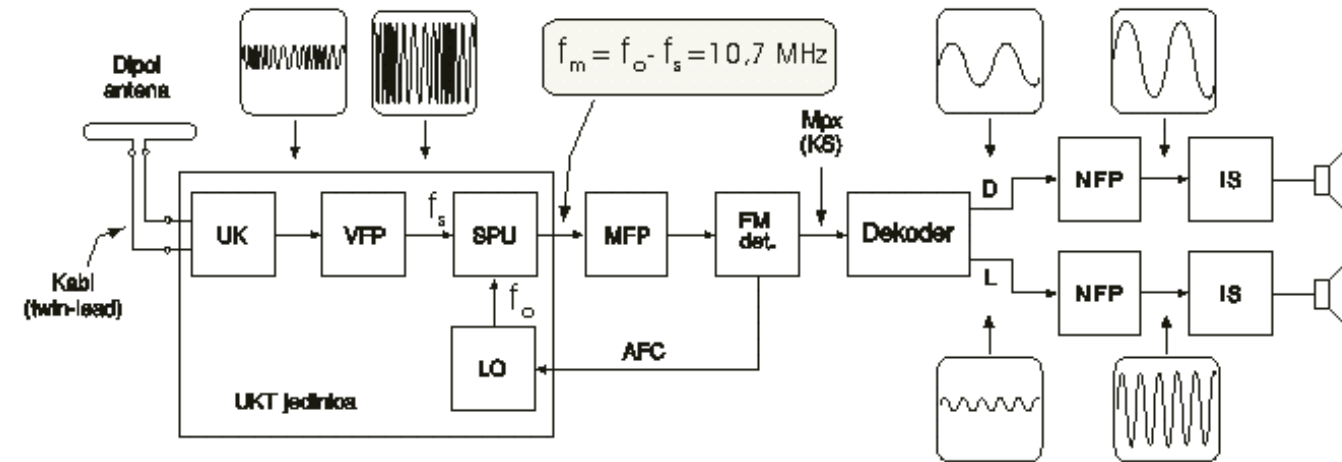
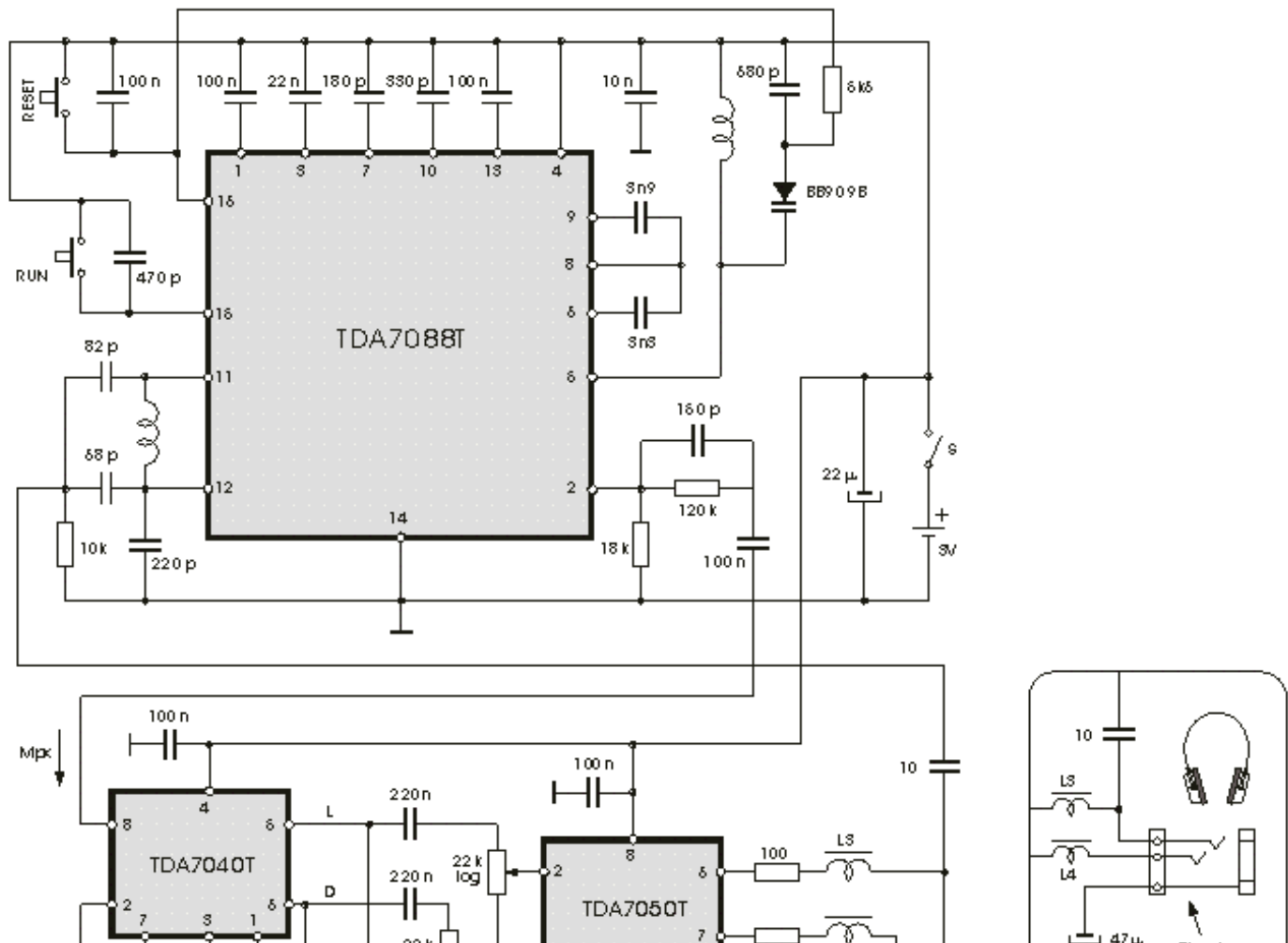
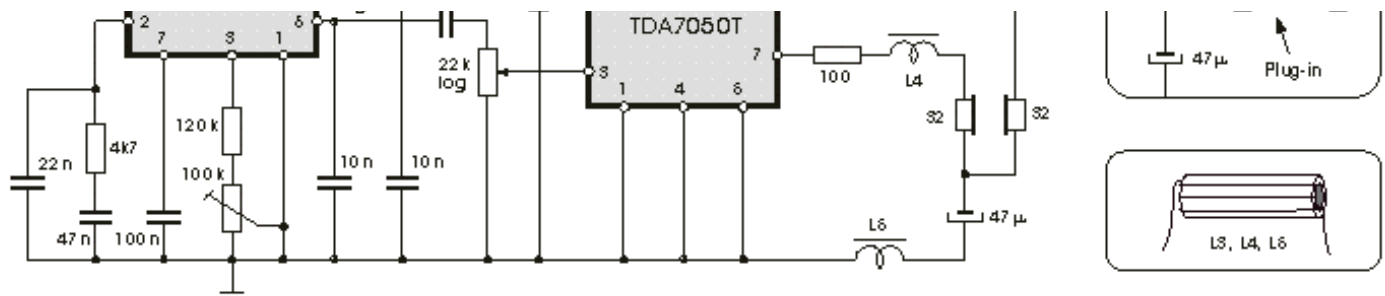

Fig. 4.18. Block diagram of a stereophonic FM receiver

Making an introduction to this part, a operating principle of the stereophonic radio receiver shall be considered, its block diagram shown on pic.4.18. Comparing this diagram with the one of the monophonic receiver given on pic.4.6, one may notice that they are identical, up to the block called "The Decoder". It means that, as already described, exiting the FM detector the LF signal is obtained, i.e. the information that was used to perform the frequency modulation in the transmitter. However, this is not an ordinary LF signal, but the one, called the "composed" (KS) or "multiplexed" (Mpx) signal. Besides the full-scale LF signal used by the monophonic receiver,





Pic.4.19. Electronic diagram of the stereophonic radio receiver built with TDA7088T (HF deto), TDA7040T (decoder) i TDA7050T (audio-amplifier)

it also contains the so-called auxiliary signal which allows the separation of left (L) and right (R) channels in the stereophonic receiver. E.g. if a direct broadcast of some band music is performed, the left part of performers is being recorded with one microphone (the signal marked as L), whilst the right side is recorded with the other one (it's a R signal). These two signals are being led in the FM transmitter in the stage called "the coder". Exiting the coder we have the multiplexed signal Mpx which contains, in an indirect manner, both left (L) and right (R) signal. Frequency modulation of the transmitter is being performed with the Mpx signal. In the receiver, Mpx signal is obtained on the output of the FM Detector and is then led to the decoder. This stage plays a role complementary to the one of the coder in the transmitter, therefore two signals are exiting it, the L and R signal. They are being amplified over two identical audio amplifiers, then reproduced over two same loudspeakers. The listener can now hear the left half of the performers from the loudspeaker placed on its left, and the right half from the loudspeaker that is placed on its right. The performers that are situated in the middle of the orchestra are being equally reproduced from both loudspeakers, making an impression to the listener as if there's a third loudspeaker, located in the middle, between the left and right one. Based on all this, the listener has a picture about the layout of the performers in space, which significantly improves the total musical impression.

Electronic circuit of a portable stereophonic radio receiver with headphones reproduction, made with TDA7088T is shown on pic.4.19. It is a receiver whose practical realization was described in the previous project, with decoder with TDA7040T and dual audio amplifier with TDA7050T blocks added, the latter was discussed in PE5.

* L3, L4 and L5 are HF chokes that allow for the headphones cable to be used as a reception antenna. This is accomplished by connecting one of the headphones' contacts from the plug-in, over the 10 pF capacitor, to the point where, acc. to pic.4.14, the outside antenna is connected. The coils represent big resistance to the station signals, preventing them to "go to ground" over the 47 mF capacitor or over the TDA7050T output. Each coil has 3 quirks of the 0.2 mm CuL wire, threaded through ferrite pearls, as shown on detail in the right corner of the pic.4.19. If telescopic antenna is to be used, these coils should be omitted.

Chapter V APPENDIX

[5.1. Making PCB's](#)

[5.2. Computer - Aided Radio Receiver Control](#)

[5.3. Receivers with NE612 IC](#)

[5.3.1. Synchrodyne AM Receiver](#)

[5.3.2. AM Receiver with Synchro - Detector](#)

[5.3.3. Input Circuits for the Receivers with NE612](#)

[5.4. Universal Audio Receiver](#)

[5.5. Additional Circuits](#)

[5.5.1. Fine Tuning](#)

[5.5.2. Electronic Tuning](#)

[5.5.3. Signal Suppressing of Local Radio Transmitter\(s\)](#)

[5.5.4. Dual Tuning](#)

[5.5.5. Separation of Stages - Preventing the Oscillation](#)

[5.6. The Boxes](#)

[5.7. Bimboard, Protoboard](#)

[5.8. Universal PCB Plates](#)

[5.9. A Modern Oldtimer](#)

5.1. Making PCB's

Design and manufacturing of the PCB's has been explained in detail in the second issue of P.E. Here, we'll consider how to make a PCB whose drawing is already done. As an example, we'll take a drawing of the board of the receiver from pic.3.19, which measures 45 mm x 30 mm.

a. The PCB is being made of pertinax or vitroplast, i.e. a thin plate (about 1.5 mm) made of isolation material, which has a lean layer of copper put on one side. From the plate you buy in some electronic components' shop, a 45 mm x 30 mm piece should be cut. In amateur conditions, this means refracting. First, points A and B are marked on the non-copper side of the plate, acc. to pic.5.1-b. A ruler is placed over them and a groove is made by pressing with a screwdriver or a bodkin along it. Its depth should be about 0.5 mm (on picture it is shown in dashed line). When this is done, the plate is placed on the edge of the table, with copper facing downwards. With one hand the plate is pressed firmly to the table, and with the other, the piece that has to be refracted. And - it cracks just along the groove.

On the refracted piece, a new groove, measuring 30 mm from the edge, is made, and the procedure is repeated. In this way we finally have our 45 mm x 30 mm plate.

b. All of the copper has to be clean and shiny, since only in this case the etching and, later, soldering is performed quick and easy and well. If it seems to you that the copper you have just bought is clean enough, you're probably wrong. The plate must have spent some time in the shop, and the copper surface is certainly more-less corroded. The cleaning is most efficiently done with some abrasive powder (VIM or similar) which is otherwise used for cleaning of the cookers, bathrooms etc, but also the sodium bicarbonate, laundry detergent and even plain salt can well serve the purpose. Take a piece of cloth, wipe it with water, extract the water well and muss it to be ball-shaped. Dip it then in the powder, and scrub the copper until it "shines like the shiny sun". After that rinse the plate, and pay attention not to touch the copper with your fingers, since that will make it dirty again.

c. Put the plate, facing the copper up, beneath the sheet that contains the PCB layout, right under this drawing. In our example, that would be the one on the pic.5.2-a. With the pike of a bodkin the holes are made through the centers of all the contacts, and in the centers of two bigger holes that are placed sidewise, taking care not to move the plate. The bodkin has to be pressed firmly, in order to obtain good prods on the copper. When this is finished, the plate should look as on pic.5.2-b. i.e. it has to contain as much prods as there are contacts, plus two. If the drawing contains many contacts, the plate can be easily dislocated, and the procedure is to be done all over again. It is better practice then to make a copy of the picture, cut it out, and attach it to the plate with two pieces of scotch tape.

d. Drawing the contacts and lines on the plate is done with the acid-resistant marker paintstick. It can be recognized by its characteristic "alcohol smell", and is being sold in bookstores as a marker for "writing on glass". You can test it: write in the store (it will be later afterwards) something on the glass, piece of plastic and similar, wait for a couple of seconds, then try to wipe it out with your fingertip. If the paint remains - the marker is OK. Nevertheless, this test isn't 100% certain, it is much better to buy the marker in the electronic components store (you have to accent to the salesman that you need a marker for drawing lines on PCB's). With the tip of the marker draw a circle around every prod (except those two that are

for bigger holes), measuring 2-3 mm in diameter. Move the marker slowly, in order to leave a thick layer of paint on the plate. Take care to leave a small copper isle around every hole. Then,

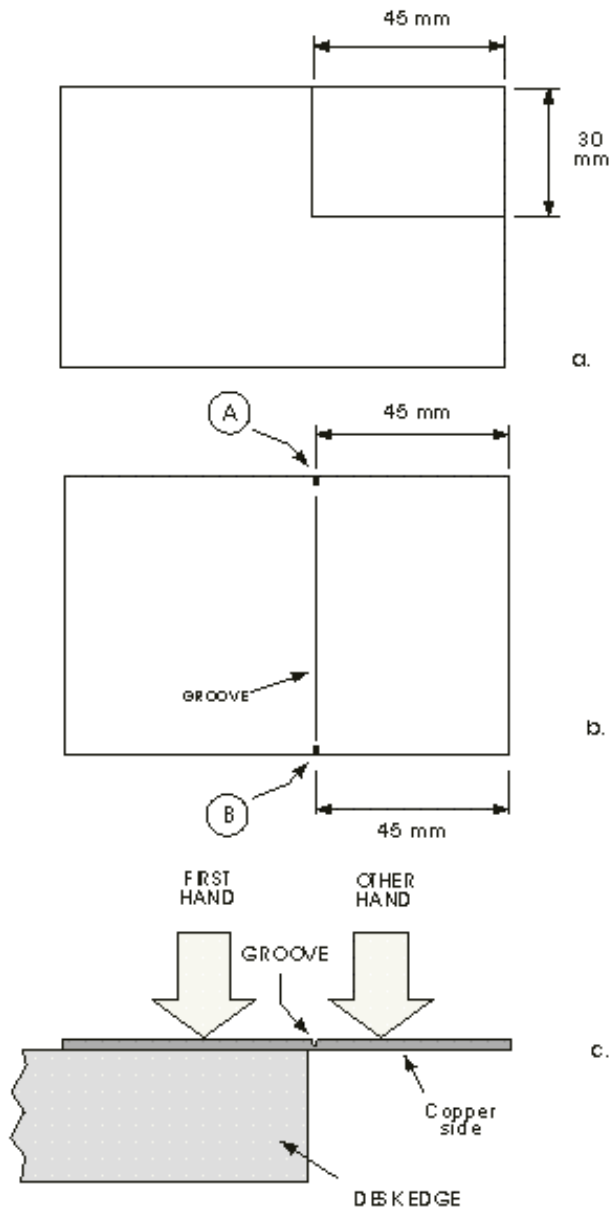

Pic. 5. 1. "Cutting" of the plate: a-*perlinax* plate, b-marking, c-cracking

you should, carefully and slowly, draw all the lines, by looking at the pic.5.2-a. They do not need to have the same shape as on the picture, especially they don't have to be that "chamfered". Line thickness should be about 1 mm, but that either is not obligatory, they can be somewhat thinner or a lot thicker (where applicable). The important thing is not to connect the nearby lines or contacts during the drawing, i.e. not to make junctions that do not exist on the drawing. If that happens anyhow, remove the paint surplus with a razor or a small, sharp screwdriver. Pic.5.2-c shows the beginning of drawing, several contacts and 3 lines are drawn. The drawing is finished when you have a pic.5.2-a on the copper foil.

e. Next step is etching, i.e. removing the copper that is not covered with marker paint. For this purpose, a mixture of hydrochloric acid (HCl), hydrogen peroxide (H₂O₂) and water (H₂O). Pure hydrochloric acid is not used, but its 35% solution, that is being sold as a household cleaning agent. Hydrogen peroxide is being sold in drug stores and cosmetic stores. It is being sold as 30% solution, or even more diluted, 8-12%.

Hydrochloric acid and hydrogen peroxide are very aggressive media, especially for the eyes and skin, therefore care should be exercised when working with them. It would be the best for you to work with them in the bathroom, or some other place close to the running water supply. If some of these liquids spills on your skin, metal tool or clothing, wash them down with water immediately.

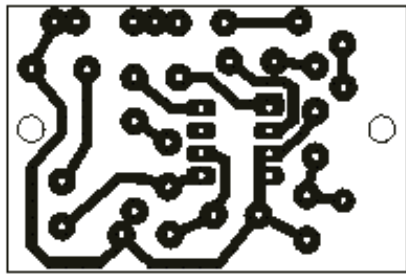

a.

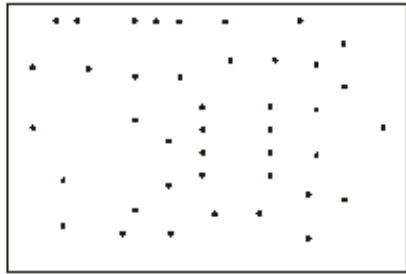

b.

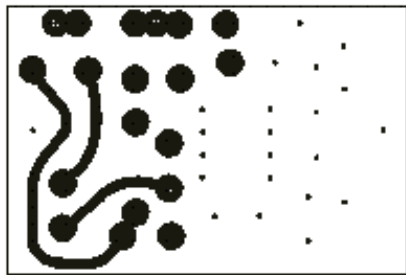

c.

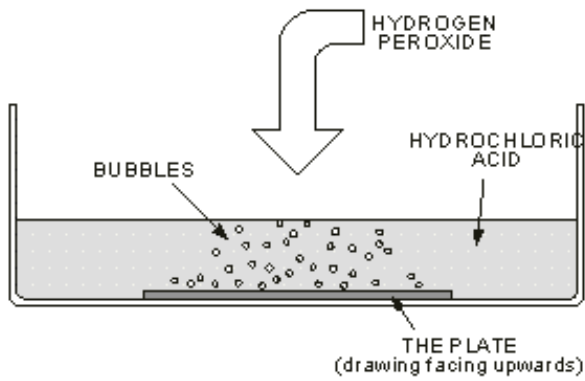

d.

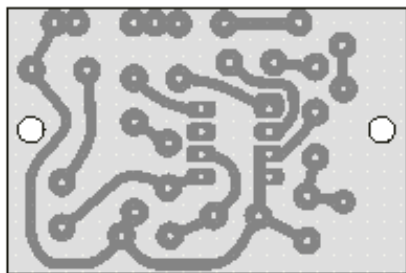

e.

Fig. 5.2. Making a PCB: a-drawing, b-plate with bodkin prods, c-drawing contacts and lines, d-etching in the hydrochloric acid while adding the hydrogen peroxide, e-finished plate

The etching mixture is being made directly before the etching, and is CERTAINLY being disposed of, right after the process. The plate is put at the bottom of a plastic, glass or porcelain dish, with copper facing upwards, and the acid is poured, in quantity enough to fully cover the plate (pic.5.2-d). Hydrogen peroxide is then added, being poured from the container directly over the plate. The amount of peroxide depends on its concentration, as well as on the concentration of the acid. So, put some peroxide, raise a little left end of the dish, then the right one, to allow a liquids to mix, and observe the plate. The mixture is transparent, and if the copper starts changing the colour after a dozen seconds - the etching has begun. During this process, the bubbles are formed in the mixture, in the amount somewhat more than in a glass of mineral water. If too little bubbles are present, add some more peroxide. Be careful, however, not to exaggerate, since if you happen to have too much bubbles, the mixture is going to heat up and the marker paint can be destroyed. From time to time, you should raise one end of a plate with a pointed wooden or plastic stick, in order to remove the old liquid from its surface, and allow for fresh mixture to take its place.

Etching is finished when there is no more uncovered copper on the plate. Raise one plate end with the stick, wait for the liquid to decant, take a plate with a laundry clip and wash it thoroughly in a jet of running water. You can then remove the paint by scrubbing, as previously described, with a wet cloth dipped in some powder. The copper contacts and lines will emerge on the plate.

f. If you were careful enough to leave a uncovered isle of copper in the centre of every contact, after etching this will be a small cavity, in the centre of the contact. Through these cavities, that will guide your drill, a 1 mm holes should be drilled (it is better if the holes are 0.8 mm in diameter, but such drills are harder to find, and a lot easier to break). Two holes for the fixing screws are usually about 3 mm in diameter. While drilling, a piece of thicker plywood or some flat hard-wood plank (beech, oak) should be put beneath the plate, and not a piece of polystyrene or something similar. Do not press the drill too hard, since the tool will be plucking tiny pieces of plastic on the other side of the plate.

5.2. Computer-Aided Radio Receiver Control

In Book 7/8 of Practical ELECTRONICS methods for simple control of various electrical devices by computer were discussed. Practical realization of various interface circuits and sensors was described, by which the computer is being connected with the outside world, so that it can turn on/off the heater, light, fan, TV set or some other electrical device at the desired moment, based on data comprising temperature, light intensity, humidity etc. In this chapter we shall present, in short terms, one of the projects from the aforementioned book, that deals with simple computer-aided turning on/off of the radio receiver at the desired moment.

The radio is connected with the computer via parallel port, the one where the printer is also being plugged. It is a 25-pin female connector, called Sub D-25, which is given on Pic.5.3.

With appropriate programme, logical ones (voltage +3.6 V) and zeroes (0 V) can be sent to the outputs marked as DI-1, DI-2,...DI-8, that are located on the legs marked with numbers 2 to 9. Electrical devices that are being controlled are connected to these outputs over the interface circuit that is given on Pic.5.4. Two connected devices are shown on the picture, their maximum number is 8.

Pic.5.5-a shows the electronic diagram of an extremely simple interface circuit, which can serve to connect to computer the radio receiver, that can then be switched on or off at certain time, with adequate programme. The low-power transistor BC547 can be used for the consumers that use the current from the battery that is not greater than 100 mA. In case you have bigger power consumers, some stronger transistor or two transistors in Darlington junction can be used instead of BC547. The transistor base is connected to the pin No.9 of the mail Sub D-25 connector over the R1 resistor, while the emitter and minus pole of the battery are connected to the pin No.25, i.e. to the computer ground. As long as there's a logical zero on the DI-8 output, the base voltage is zero and the transistor is locked and no current runs through it, therefore also through the consumer. When a logical one emerges on the DI-8, the transistor goes to the saturation regime, the voltage between collector and emitter becomes very small (practically zero) and the transistor behaves as if the collector and emitter are short-circuited. In that way almost the entire battery voltage is available on the receiver power supply input.

The PCB layout is shown on Pic.5.5-b: The component side is in the upper part, and the soldering side in lower part of the picture.

Pic.5.5-c shows how a small transistor radio receiver, powered by a 9 V battery, is connected to the parallel port, over the interface from pic.5.5-a. The plate is connected with clamps via the cables A and B, and with the battery over C and D.

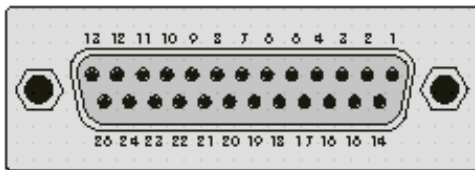

a - Sub-D-25 Connector located on the computer housing back plate, female type, front view

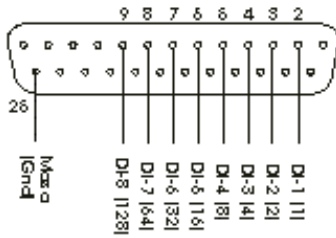

b- Pin marking on the Sub-D-25 Connector

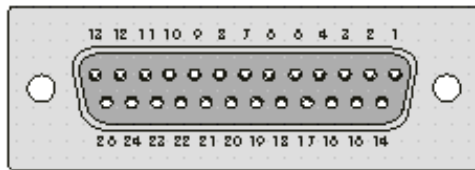

c-Sub-D-25 connector, male type, watched from behind, from the side where the soldering legs are

Pic.5.3. Parallel Port

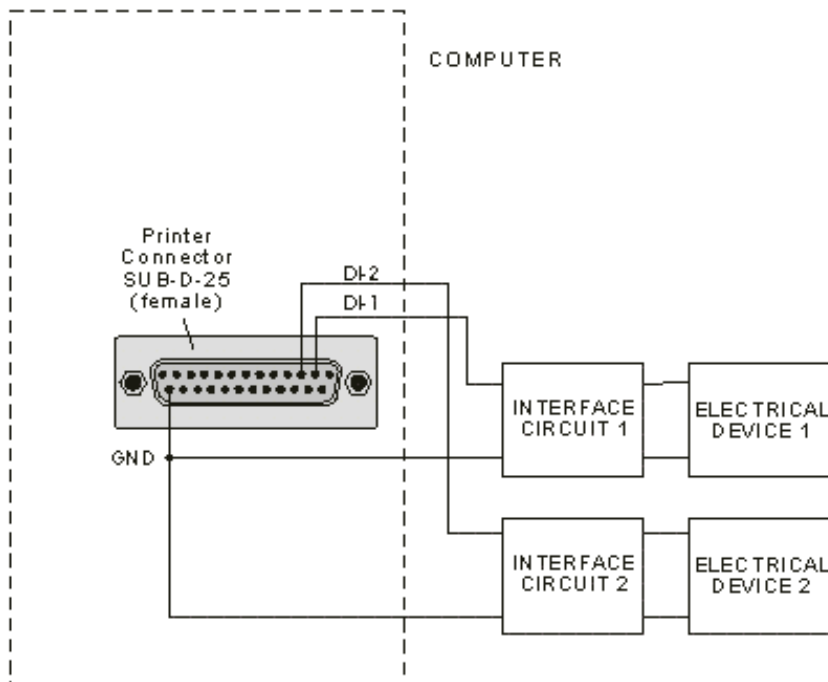

Pic.5.4. Connecting electrical devices onto the parallel port

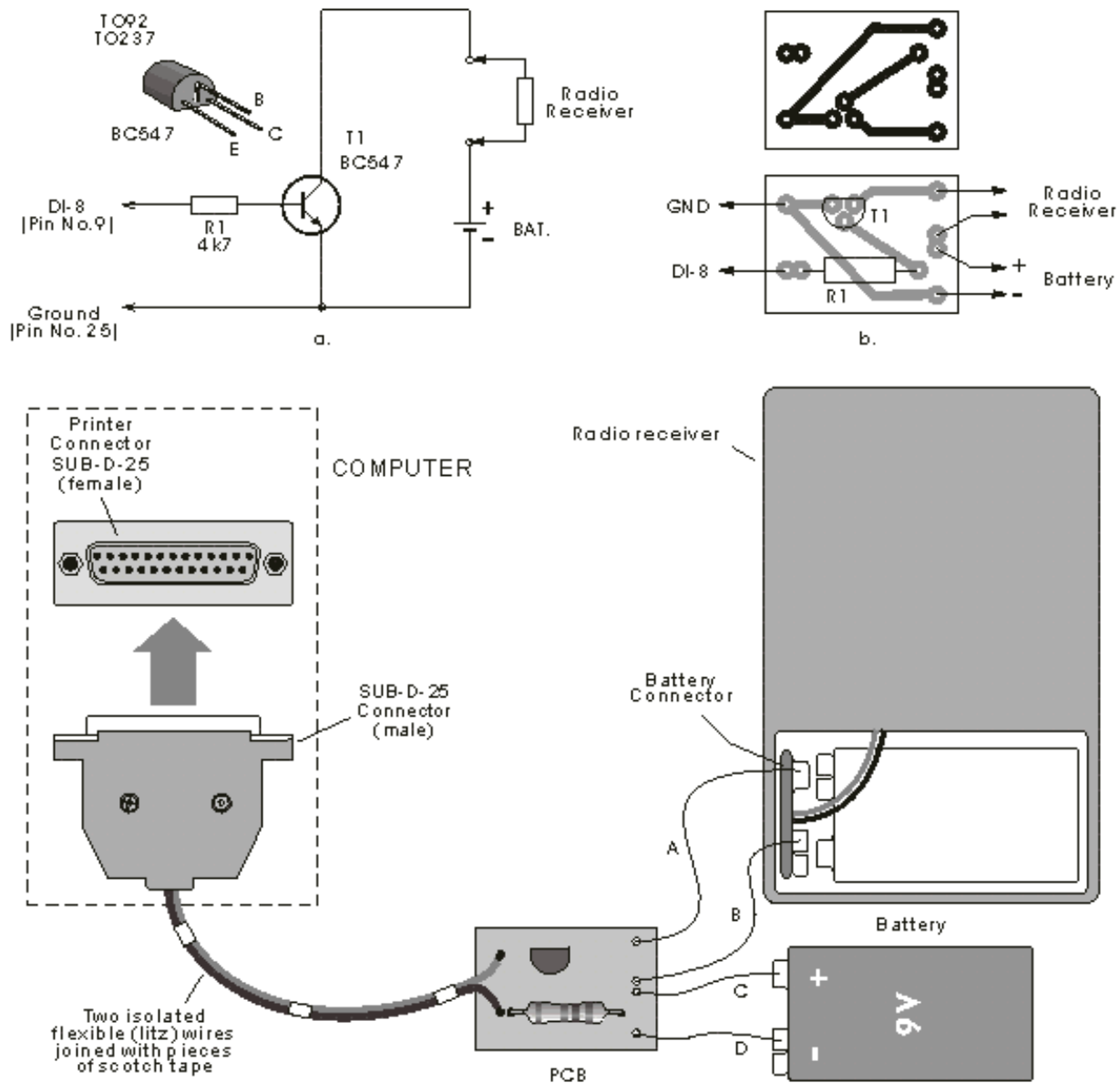

Pic. 5. 5. Connecting the Radio Receiver to the Parallel Port : a- Electronic diagram of the Interface Circuit, b-PCB, c-Connecting the Computer, Interface Circuit, Receiver and the Battery

5.3. NE612

5.3.1. Synchrodyne AM Receiver

If the author remembers well an article that he read in a professional magazine many years ago, the synchrodyne receiver is the ancestor of the superheterodyne receiver. Sometime at the beginning of the 20th century this device was called the Heterodyne receiver, and it was first constructed by Levvy. Armstrong improved it and gave new name to the new device, by adding the prefix SUPER to the old name.

The electronic diagram of this device is given on Pic.5.7. This receiver, as well as that on pic.4.2 has got the local oscillator with oscillatory circuit connected between pins 6 and 7. However, frequency of this oscillator is not greater for the value of f_m , but is in fact equal to the frequency of the station we wish to listen to: $f_m = f_S$. Because of that, the important design difference compared to the diagram from pic.4.2 is that on pic.5.7 capacitors C_o and C_{to} are not used, but the capacitor C which is obtained by connecting the legs O and A, acc. to pic.3.7. Its capacitance can be changed from 12 pF till 218 pF, so that the oscillator frequency, in case of MW reception, goes between 500 kHz to 1500 kHz. The oscillator voltage is emanated in the mixer by the signals from all stations coming from the antenna. The result of emanation with signal of the station whose frequency is equal to the oscillator frequency is the LF signal (speech, music, Morse Code etc.) that serves for performing the modulation in the transmitter. This signal is obtained on pin No.4, from which it is then led, over the 1 μ F capacitor, to the volume potentiometer and audio amplifier. Products of mixing the oscillator voltage with other stations' signals are also obtained on that pin.

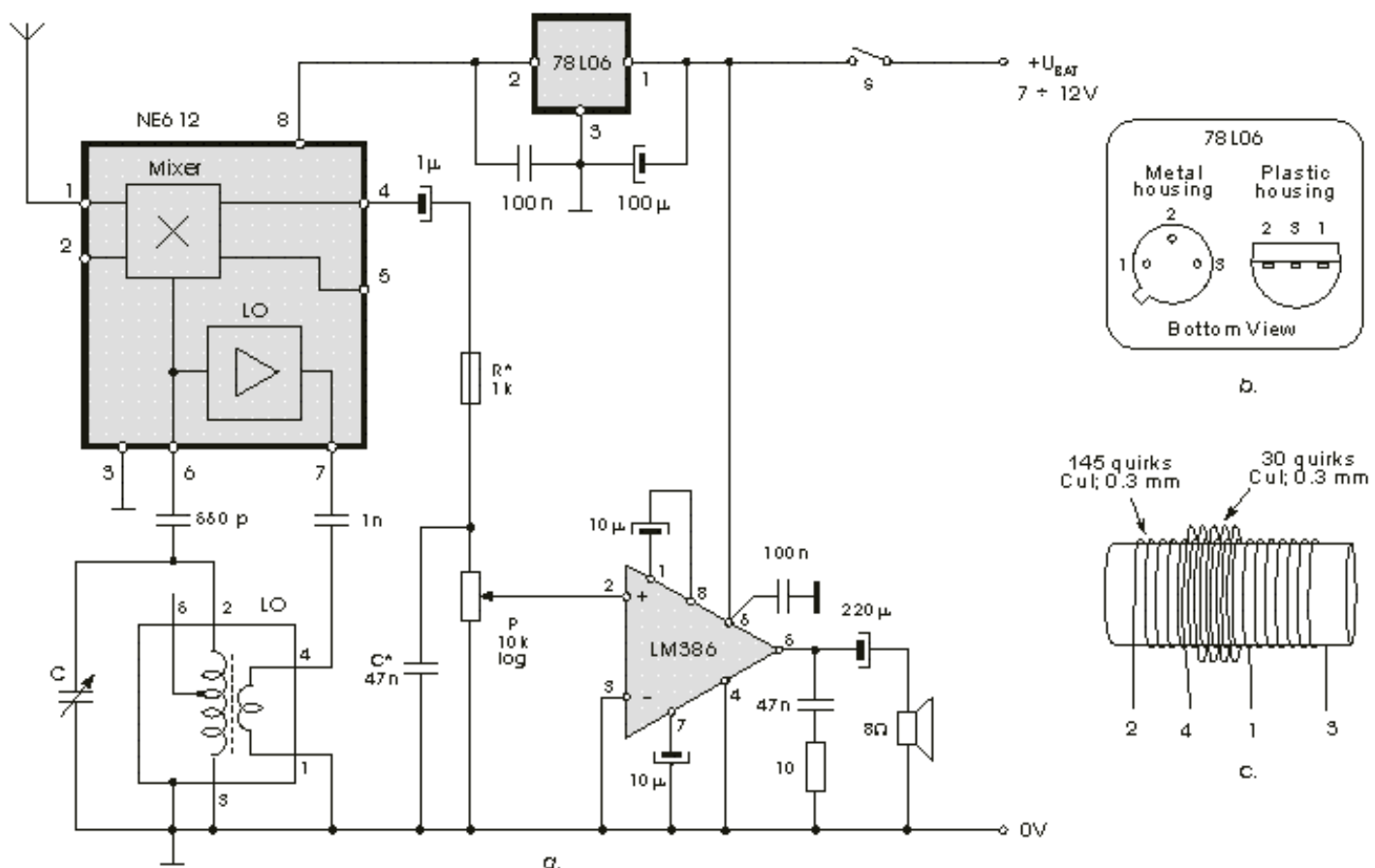

Pic. 5.7. Synchrodyne AM Receiver: a-Electronic diagram, b-Pin layout for 78L06, c-Oscillator coil

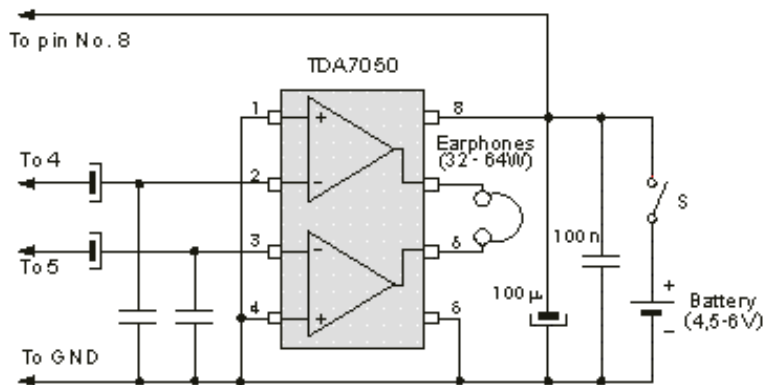

Fig. 5.8. LF part of the Receiver from pic. 5.7

They are being suppressed by the LF filter that comprises the R^* resistor and C^* capacitor. The device we were testing did not, however, contain R^* . It is to be installed if some disturbances occur (whistling or similar), and its optimum value is to be found experimentally. If necessary, greater capacitance of C^* is also to be tried out.

* As mentioned earlier, it is very important for the supply voltage of the NE612 to be stable. This values even more for the synchrodyne than the superheterodyne receiver. The voltage control is done by the stabilizer, made with 78L06 IC. It is being placed in the low-power transistor package, either metal (as for BC107) or plastic (as for BC547), and its maximum current is about 100 mA (pic.5.7-b). A simpler stabilizer, made with the Zener diode, can be used instead, as on pic.5.9.

* Instead of factory-made coil LO, the self-made one can also be used. The simplest solution is to use the one from pic.3.6, in which case the mid leg is not used. Over this coil, the feedback coil should be wound, acc. to pic.5.7-c (its ends are marked with 4 and 1). When connecting with capacitor C and pins 1 and 7 of NE612, care should be taken to join properly: coil ends 1 and 3 with ground, 2 with capacitors C and 560 pF, and 4 with 1 nF capacitor. It is, of course, possible to use smaller coil, wound on a smaller body, with more quirks of thinner wire. Its inductance should be about 350 mH, and the number of quirks required is to be found by testing. The feedback coil (4-1) has app. 3x fewer quirks than the oscillatory circuit coil (2-3).

* On the pin 5 of the NE612 the LF signal is also obtained. It is the same as the one on pin 4, but has a 180° phase shift compared to it (in simple words, while one signal increases, the other one decreases, and vice versa). That gives us the opportunity to use the dual audio amplifier in the LF part, that has two amplifiers, with inverting and non-inverting inputs. As shown on pic.5.8, the counter-phase LF signals from NE612 are led onto the same inputs. The output signal has 2x greater amplitude, therefore making the output power 4x greater than when only one input is used (as on pic.5.79).

5.3.2. AM Receiver with Synchro Detector

In previous project, the NE612 was in fact used as the AM signal detector. The LF signal exiting the mixer is product of the simultaneous (synchronous) action of the station signal and voltage from the local oscillator upon it. That is how the term "Synchro Detector" emerged. There's also a possibility to use a station carrier instead of local oscillator's voltage, so that the station signal gets beaten by itself, however strange this may sound. Electronic diagram of one such device is given on pic.5.9.

The station signal, which the input circuit (C, L) is tuned at, is led to the regulating Gate of the BF960 MOSFET. Under the effect of this voltage, the AC current that creates voltage drops on resistors R2 and R3 runs through the transistor. These two voltages, taken between the S and ground and D and ground, are mutually shifted in phase for 180° , and are being led over the coupling capacitors C2 and C3 to pins 1 and 2 of the NE612, i.e. on one input of the mixer. On the other mixer input the Drain signal is brought, over C4, and beating occurs in the mixer, the result of which is the LF signal on pin 4. This signal is, over C8, being led onto the volume regulation potentiometer and the audio amplifier.

* The unwanted (and parasite) products of mixing, that are manifested as whistling, squeaking etc. are being suppressed by the C7 capacitor. If the obstructions still exist, the capacitance of C7 is to be increased and/or the R^* resistor added.

* The voltage stabilization of the DC voltage on pin 8 is performed by the ZPD6.2V Zener diode and resistor R5. A diode with smaller voltage is also possible to be used, say, 6.2 V and similar. If the supply voltage is less than 12 V, the resistance of R5 should be decreased.

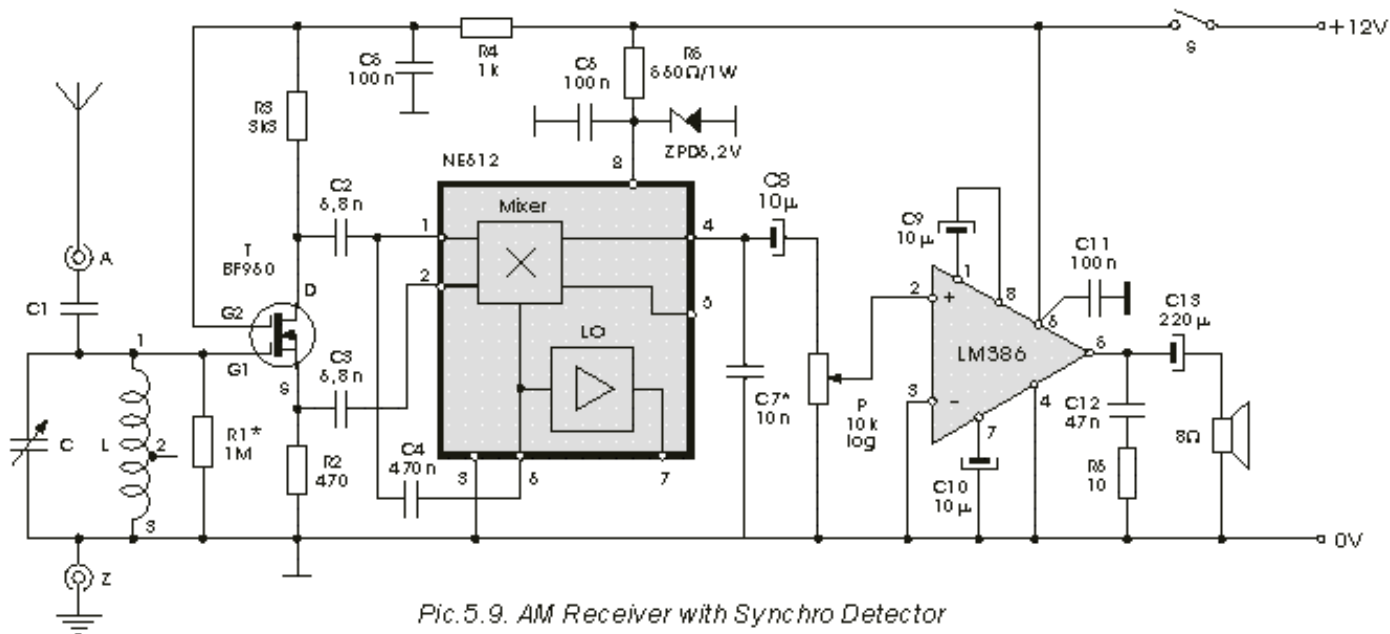

Pic.5.9. AM Receiver with Synchro Detector

5.3.3. Input Circuits for Receivers with the NE612 IC

All the receivers with NE612 that are described here work better, especially considering suppressing the noise in case of the symmetrical station, if the proper input circuitry is added to them. Pic.5.10 shows two examples of the MW receivers that use the ferrite antenna. In both cases, the antenna taken from an old commercial radio is being used.

5.4. The Universal Audio Amplifier

We already spoke about the universal amplifier in the text connected with pic.3.22. Pic.5.11 contains the diagram of another such device, where the transistor amplifier with BC547 is used as the pre-amplifier, instead of that with TLO71 IC. It can be used for practical check of all the earlier mentioned radio receivers. The LF signal is being taken from the detector in the HF part of the receiver to the hubs marked as In and Gnd (if the links aren't too long the ordinary wires are used, otherwise - the microphone cable). On the third hub the DC voltage is outputted, which is used in some HF circuits for their operation (such as e.g. those on pics.3.24, 3.25, 3.29 etc.).

* The LED (and the appropriate resistor) are added if the amplifier is being supplied from the adapter connected to the household voltage installation. It can also be used if the amplifier is power supplied from the battery, but this is not recommendable, since its power consumption is fairly big, which significantly shortens the battery life.

* The amplifier can be put in a box of any kind, one of the possible solutions shown on pic.5.11-b.

* A very useful solution can be to place the adapter also in the box, with the ability to control its output voltage from few volts to 12 V. In that case, you have both the amplifier and adapter in the same box, which can be used for power supply and check-out of various electronic devices, and not just radio receivers.

5.5. Additional Circuitry

5.5.1. Fine Tuning

During the tuning of the receiver to some station at the SW band with the variable capacitor, a problem occurs. In simple terms, the station frequencies are too close to each other, so the capacitor's shaft should be turned for an extremely small angle in order to change station, which is practically impossible. It would certainly be useful if we could somehow stretch (a popular term for this) the part of the band near the frequency to which the receiver is tuned at. For the direct type (TRF) receivers that were described in the previous chapters, this can be accomplished if, acc. to pic.5.12, another variable

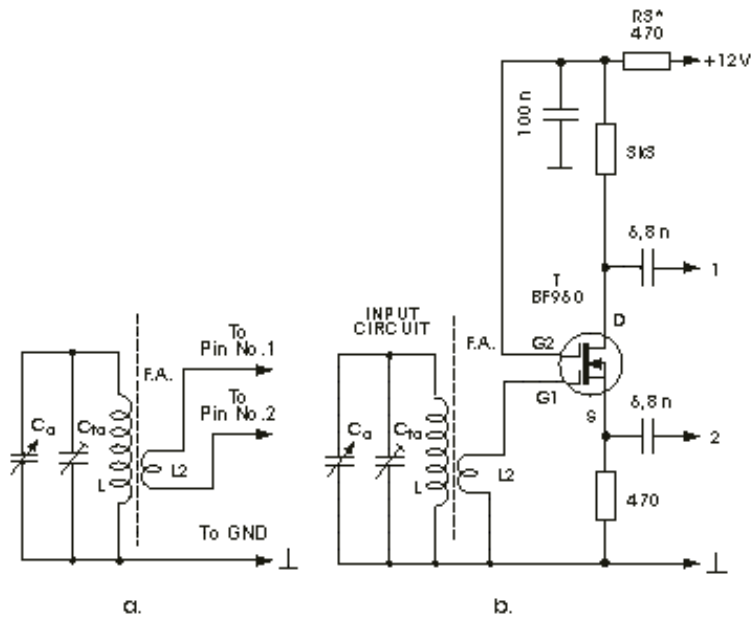

Pic.5.10. a-Input Circuit for the Receiver from pic 5.9, b-Input Circuit & HF Amplifier for the Receiver from pic.4.2

capacitor (CR) is added in parallel to the variable capacitor at the input circuit. Its capacitance should vary at substantially smaller scale than that of C, meaning from a few pF til about 20 pF. The tuning is accomplished by setting the receiver, by means of C, approx. at the middle of the band we are interested in, then tuning by means of CR to some station in that area. E.g. if the stations we want to receive are located in the part of the SW band from 6.1 MHz till 6.2 MHz (it's a well-known 49-metre band), first we tune ourselves with C to approx. 6.15 MHz, and then we pick with CR some of the stations located in that area. The same applies for the famous Magic Band (at about 50 MHz).

The CR capacitor is mounted close to C in order for their knobs to be near each other at the front plate.

* As CR, some air-type trimmer capacitor can be utilized, with adjustment knob mounted on its shaft. Also, one of the sections of the variable capacitor from pic.3.8 can be used, as shown on the right part of pic.5.12.

* The problem of the station "adjacency" at the SW band also exists at the superheterodyne receivers. It is being solved by adding the CR in parallel to the variable capacitor in the local oscillator circuit. The reason for this is that, at supereterodynes, the station is chosen over the local oscillator. The important thing for the oscillator is to have the exact frequency, that is greater from the station frequency for the amount of the interfrequency. If the resonance frequency of the input circuit isn't equal to the station frequency, it won't significantly affect the reception. Because of all this, in the receiver on pic.4.5, CR is attached between the pins 2 and 3 of the LO circuit.

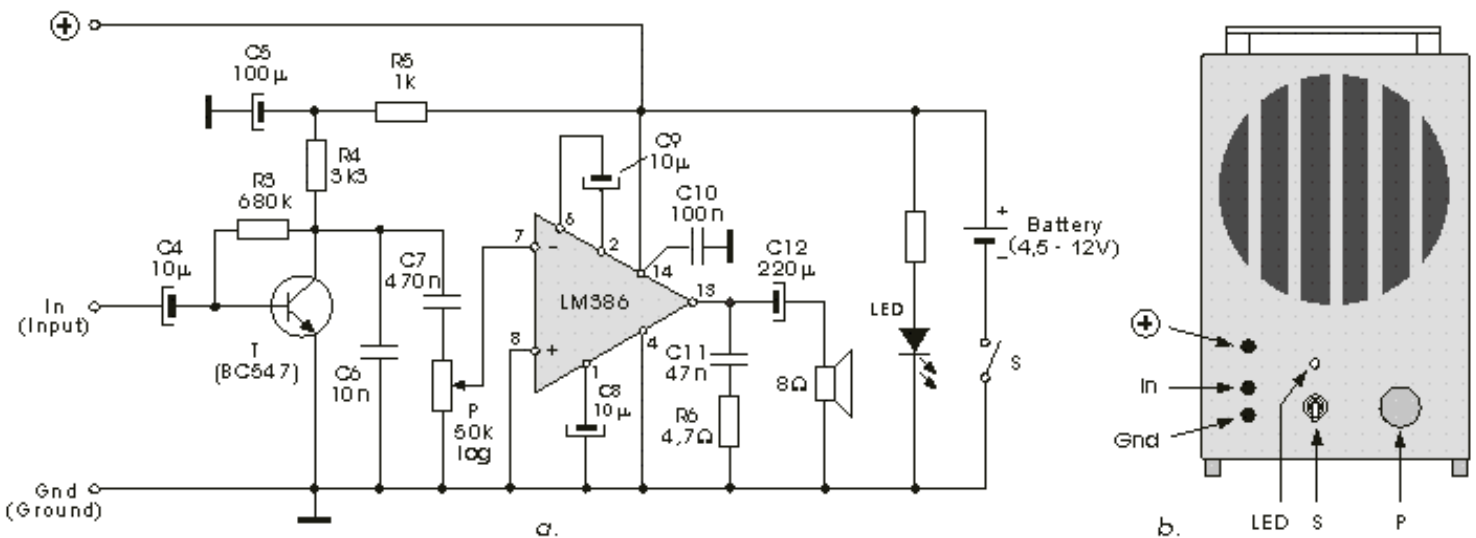

Pic.5.11. Universal Audio Receiver: a-Electronic Circuit, b-Box

5.6. The Boxes

For all lovers of the electronics, the box where their device is to be put is the famous “production weak link”. The finished boxes are either impossible to purchase, or they can be bought but their dimensions or shape is inappropriate, or they are too expensive, or... In cases like this one should be quick-witted enough to find some square-shaped box that is being used at household, or some packaging box or similar. That is how it's done in the “whole white world”. Two years ago, in the famous electrotechnical magazine ETI TOP PROJECTS the article named “TIC TAC RADIO” was printed, where a receiver with ZN414 that is placed in the transparent plastic box of TIC TAC mints (In the abstract, it was written that making this device serves well as an excuse for buying candies, which is probably meant for the readers that are on a diet for aesthetic reasons). However, the “finishing touch” is of great importance for everything. The majority of your friends will be more impressed by a lovely box where the receiver is placed, than the reproduction quality, type of modulation and other technical characteristics. And a nice, appropriate box cannot be bought, it is up to you to make it. It can be something as on pic.3.11 or similar. The idea can be also found in some catalogue of radio receivers' manufacturers, or you can think of something of your own. As far as the author of these lines is concerned, he likes best the wooden boxes from the 20's and 30's of the previous century, from the times of the charleston, E. H. Armstrong and Al Capone. They looked something like those on the pic.5.17 and can serve you as an inspiration for your personal design.

The mid button is for the variable capacitor for station tuning, the right one is for the potentiometer for volume regulation. The button on the left can be a rotary switch for turning on/off (S). It can also be a tone regulation button, and for the reaction-type receivers it can be a button of the potentiometer that regulates the magnitude of the reaction. In the last two cases, the on/off switch (S) is located on the regulation potentiometer. The outside antenna and ground hubs are located at the rear panel of the box. The wires connecting the hubs with the PCB should be isolated, flexible and long enough to be able to open the panel and put it at upright position.

If the receiver is power supplied from the outside net, a green LED should also be added, as the power indicator. The good place for it is just above the variable capacitor's button, instead of the triangle-shaped marker.

Pic.5.18 shows the parts for the first box from pic.5.17. For the front and rear side two pieces of 5 cm thick plywood, measuring 22 cm x 15 cm are needed; for the side panels, two pieces of 10 cm thick plywood, 15 cm x 9 cm, and for the bottom side - one piece of 10 cm thick plywood, measuring 13 cm x 9 cm. The best way to cut these parts is to be done by the carpenter on the special machine, since only then will they be of strictly rectangular shape, and bottom and side panels will have exactly the same width, which is very important during assembling. On the front side, the circle and the arc are drawn with the aid of the sector, and the cutting is done with the carving saw. The part that is cut from the back panel will serve as a closure. When it is cut it isn't necessary to treat it with emery, since it will fit nicely in the hole on the rear panel even if it isn't cut evenly. On the inner side of the rear panel two plywood lattices measuring about 2 cm x 13 cm should be nailed. Four wood screws will be screwed in them later (the holes are shown as four dots), which will serve to tighten the closure. Connecting of the pieces is done with the wood glue and small nails. Before you start hammering, it is very useful to drill a few holes for the nails in the front and rear panel with 1 mm drill. The nails are partially hammered into the panels, the edges are then covered with glue, and the nailing can then be done. When all this is finished, the box should look as the drawing at the right end art of the pic.5.18 *vertical stripes over the loudspeaker opening are not shown. They can be omitted, and you can nail in a few thin lattices, when the box is finished, as shown on the last drawing on the pic.5.17). The semicircle part is made of 5 mm x 5 mm lattices, or similar, which are put side by side on the upper edges of the front and rear panels, that are covered with glue (the picture shows only one of these lattices). When the last one is fitted, the space between them is filled with “putty” that is made by mixing the fine wooden chips with the wood glue, with the aid of a steel plate. After that, the lattices are tightened to the panels' edges by two pieces of strong scotch tape, which are shown in dashed lines, and everything is left to dry well. When drying is, after about 10 hours, finished, all the edges and lattice parts that protrude are well flattened with emery. All the remaining holes are filled with the fast-drying putty, and everything is abraded once again, and the putty is applied again, and abraded again, etc., until the upper part is semicircle-shaped, all the sides smooth and the edges correct.

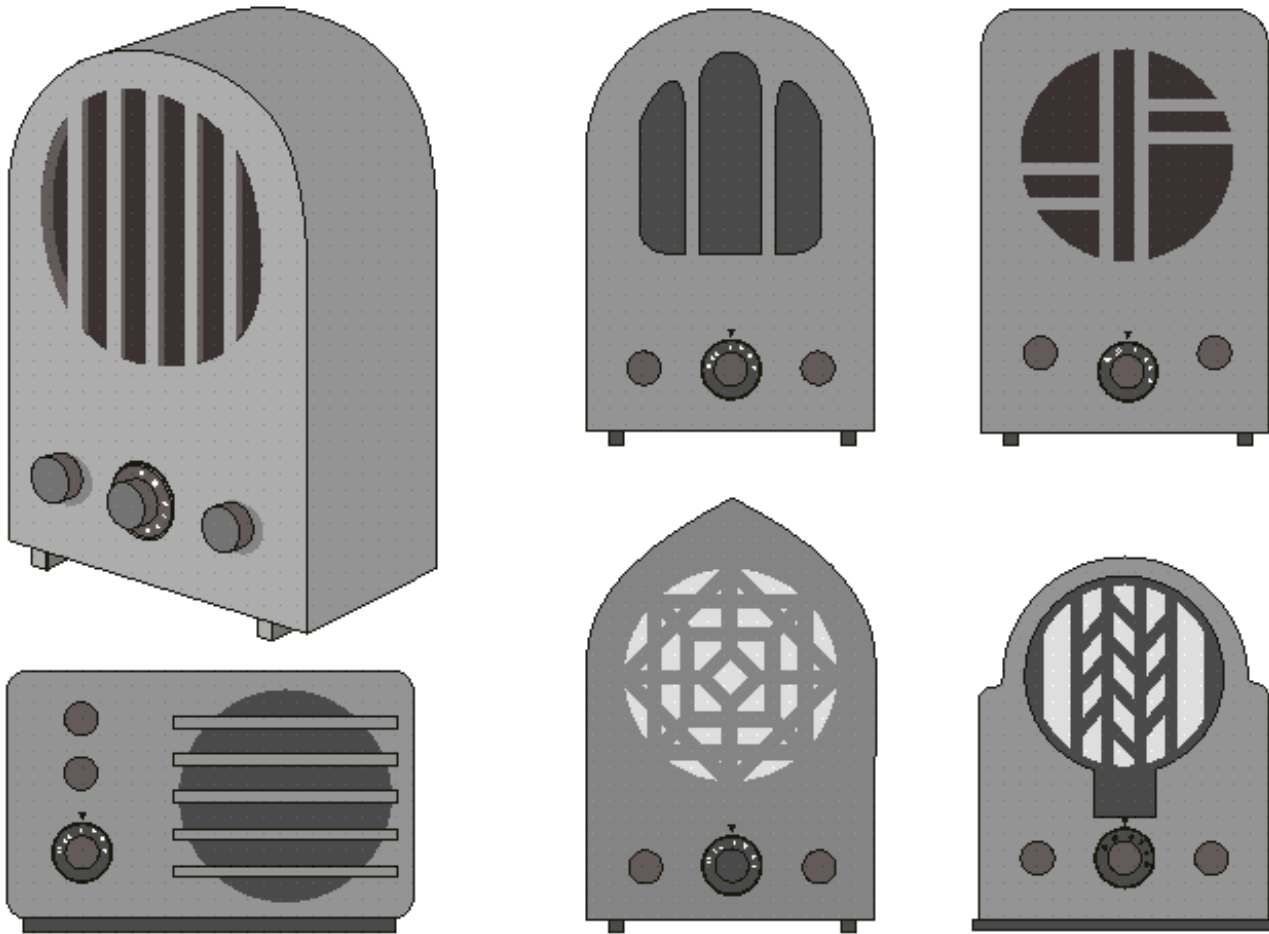

Pic. 5.17. Radio Receiver Boxes

* Before the loudspeaker is attached with screws, a piece of decorating cloth should be placed between the panel and the loudspeaker, which will protect it and contribute to better looking box.

* Perhaps some of the readers will seem that there's a lot of exaggeration in previous lines, and even too much pedantry. There's a Latin proverb, that says: AGE QUOD AGIS - Do the things you do, which, in our case, can be interpreted as: You should either make the box properly or not making it at all.

* This box is relatively small, it is predicted for the loudspeaker that is about 12 cm wide. If you have bigger loudspeaker, and it will certainly play both louder and better, you should make a bigger box. The dimensions calculation is done by dividing the diameter of the bigger opening, that will suit bigger loudspeaker, in centimetres, by 11, and all the measures on pic.5.18 are multiplied with the number attained. E.g. if the diameter for the new, bigger hole is 15 cm, new dimensions are obtained by multiplying the old ones by 1.36.

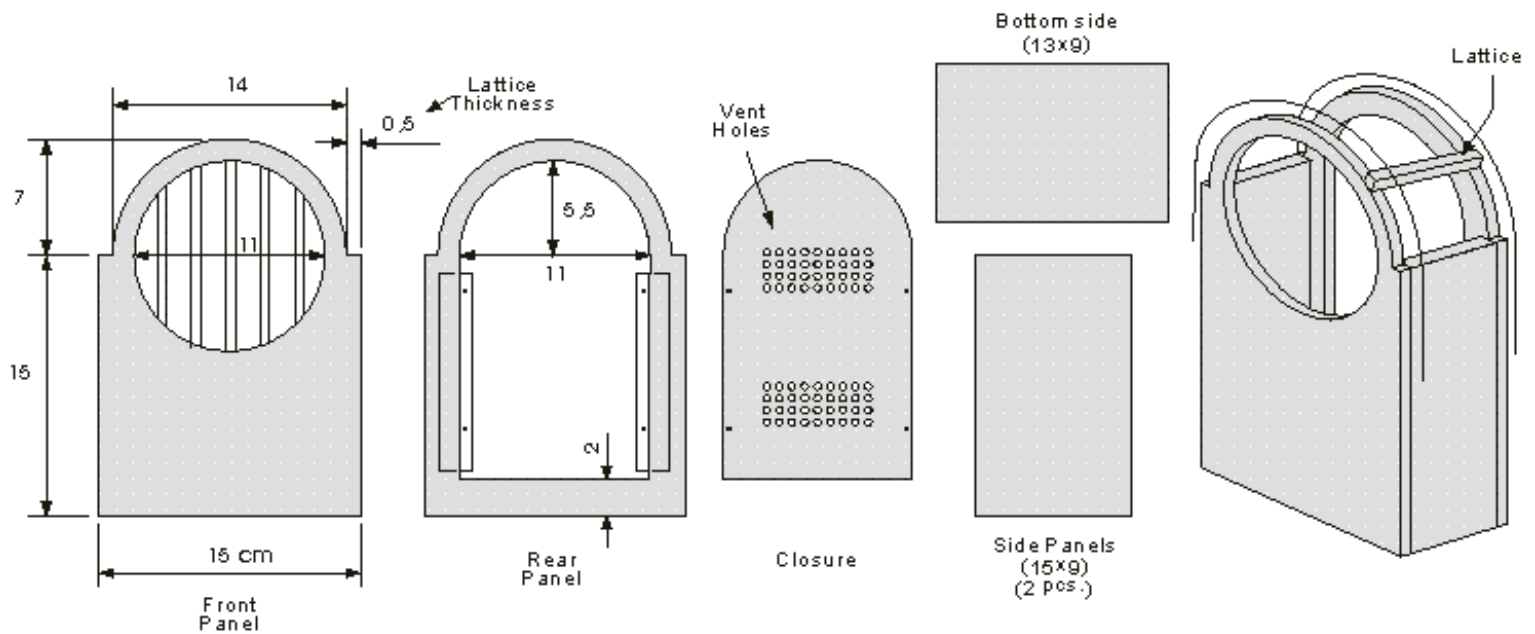

Pic.5.18. Parts of an old-fashioned Radio Receiver's Box

5.7. Bimboard, Protoboard . . .

The readers that have carefully studied all the radio receiver projects that are described here, have possibly noted that the author referred to experimenting either with values of some components or with entire circuits, and all that was in order to practically find the optimal solution. When small changes are discussed, such as finding the optimum value for some resistor, that can be done on the previously made PCB. In case of bigger changes that of course is not convenient, and sometimes it is almost impossible. For all kind of electrical diagrams check-outs as well as various experimenting with all electronic devices, including radios, it is the best to use a special experimental board, which can be purchased under various trade names: protoboard, bimboard, matador, steckplatine, steckboard etc. All of them have in common that component connecting is done without soldering, by simply inserting the legs into the small holes on the plate.

As an example, pic.5.19 shows a full-scale experimental board that can be purchased in one of the Belgrade electronic shops. It has 630 vertically aligned holes, connected internally in 126 groups of 5 holes each, and another 100 holes placed in two topmost lines, connected in two horizontal groups by 50 holes each. The connections between the holes are inside the board and cannot be seen, they are shown on picture in dashed lines. The two topmost parts are used to bring the supply voltage, and the battery or the adaptor is connected to them. One of them, most often the one that has minus pole connected to it (in all the devices described herein), also serves as the device Ground. The holes contain miniature metal hubs that are elastic, so when a leg is popped in, a reliable mechanical and electrical junction is accomplished. The distance between the adjacent holes is 2.54 mm (1/10 inch), which allows for connecting the vast majority of electronic components, which are being produced with inter-leg distance that is equal to a hole number multiplied with 2.54 mm (in the producers and sellers' catalogues the 2.54 mm distance is marked as R, which stands for raster, and the components that have their legs horizontally and vertically distanced to 2.54 mm multiplied by some whole number are said to have their legs in raster).

The necessary electrical junctions between the hole groups are accomplished with connecting wires that can be bought at Conrad, but are more often self-made from plastic-isolated 0.5 mm or 0.6 mm copper wire. These pieces vary in their length and can be bent as the biggest piece in the lower left part of the pic.3.19, although it is better and nicer to use regular pieces, shaped as the cyrillic letter P.

Pic.5.19 also shows an example of practical usage of one such board. The radio-receiver from pic.3.15 is made on it. As can be seen, the coil ends are stuck into the holes whose coordinates are j,37; j,39; i,45; i,47, the diode in holes i,39 and i,45, the pin No.1 of the IC in e,54, etc. With the connecting wires the legs No.1 and 3 are connected, the ones that are connected with the potentiometer slider, and legs No.2 and 4 are connected to the ground by means of 4 connecting wires (the minus pole of the battery), etc.

It is now clear that experimenting is done in a very simple manner. E.g. if you are interested how does a capacitance of C2 affect the tone colour in the headphones, all you should do is remove it and insert a capacitor of greater or smaller capacitance, etc.

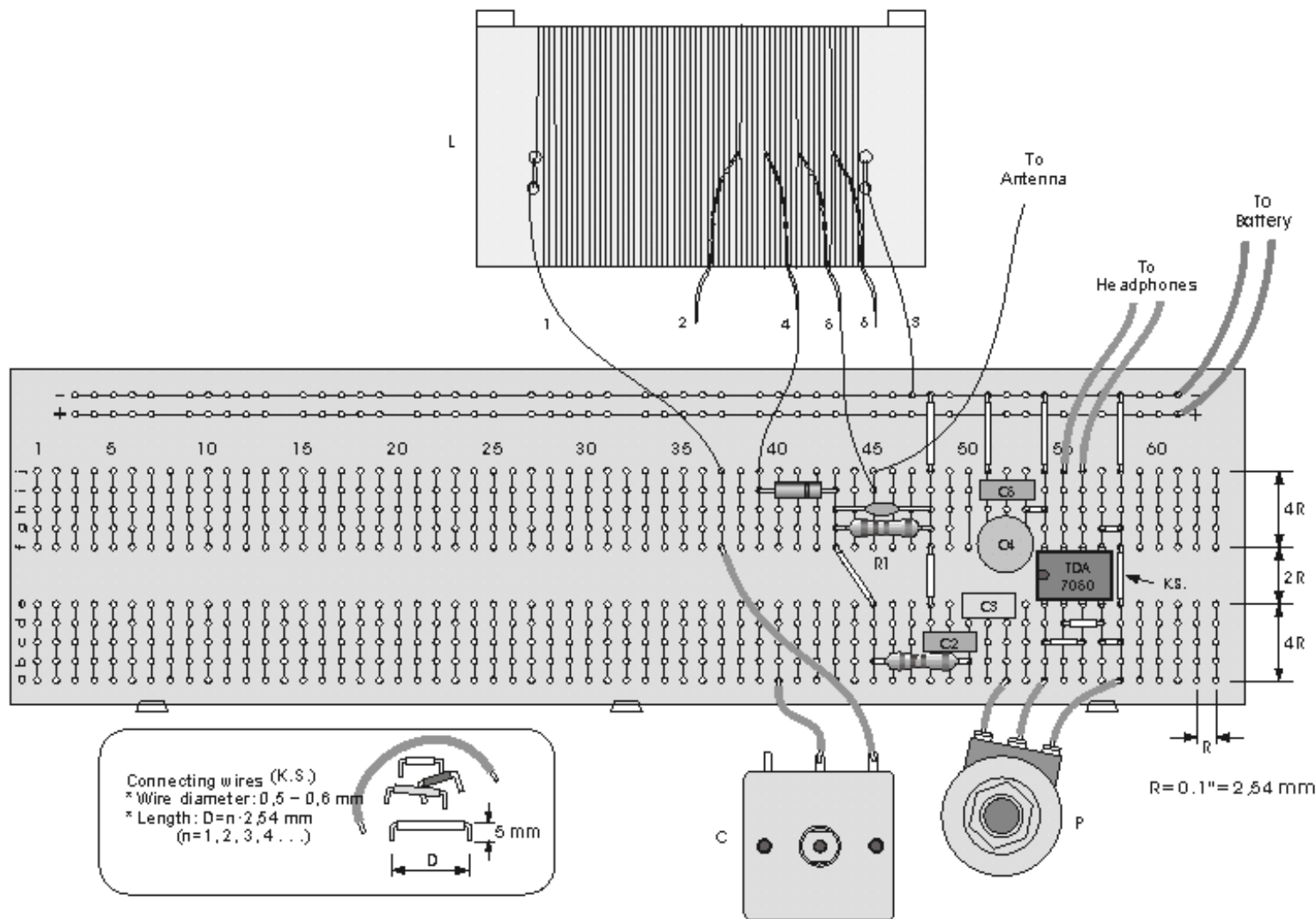
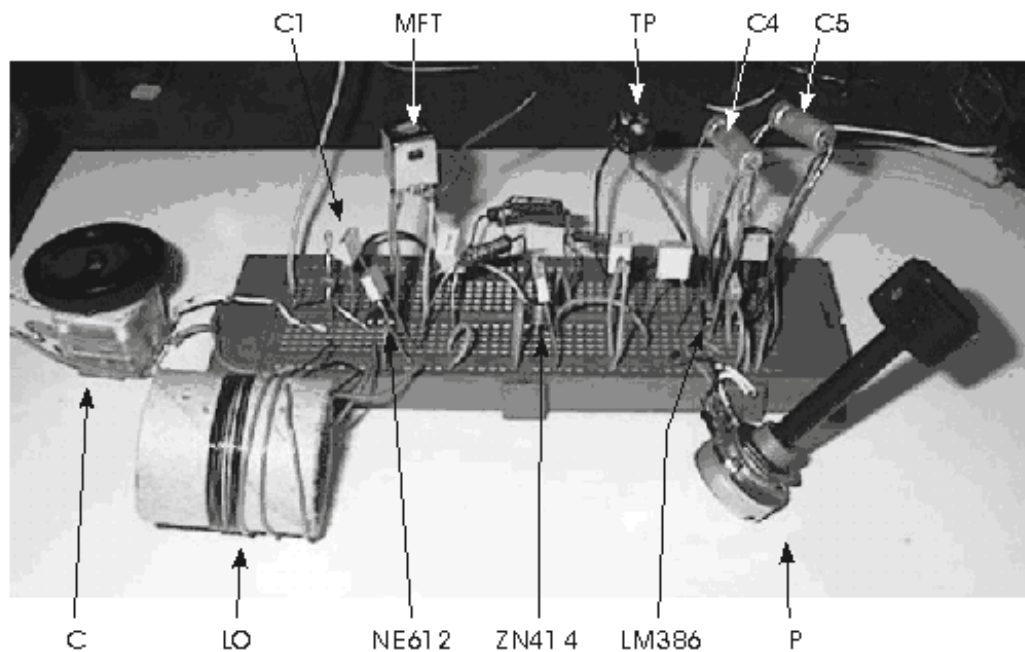

Fig.5.19. The Receiver from pic.3.15 Mounted on the Protoboard

* The hubs on the board are elastic, so that conductors of various diameters can be easily inserted. No wires much thicker than 0.6 mm should be inserted, since the hubs will deform. The components whose legs are too thick as the variable capacitors, potentiometers, transformers and similar, are connected over pieces of wire that are soldered to them.

* It is useful for the connecting wires to be made with isolations of various colours, so that red ones could be used e.g. for connecting with the + battery pole, the black ones with Gnd, the yellow ones for the signal etc.



Pic. 5.19-b The Receiver from pic. 4.5, with the SW Coil, mounted on the Bimboard

5.8. Universal PCB

Practical realization of simple radio receivers, as well as other simple electronic devices, can be done in many ways, as it was discussed in PE No.2. One of those is shown also in this number. That is construction of the detector receiver from pic.3.11, where some of the components are mounted onto the box walls (the variable capacitor, coil and the hubs), while other (the diode and two block-capacitors) are placed between them. With some skills, and by the aid of few smaller nails nailed from the inside of the front panel, a more complex device could be made, say, that from pic.3.12. But this solution would start looking as "the dead cockroach technique", which will be discussed in the "Funniest Electronics". The real solution is the PCB that can be made from the drawings that are given, or those you will draw yourself, together with the instructions given in chapter 5.1. There's another option for practical realization. It is a universal PCB, that can be bought in the electronic components' stores. There are more sorts of these PCB's, and all of them have in common that the holes on them are drilled on the distance of 1/10 inch ($R=2.54$ mm).

One of the universal PCB's is shown on pic.5.27. It consists from a huge number of round copper isles, with hole in the middle. The components are being soldered first (resistors, diodes, IC's, capacitors...), and then the component pins are connected by pieces of isolated copper wire, on the soldering side.

As an example, pic.5.28 contains the photograph of the receiver from pic.3.21-a that is made with the universal PCB from pic.5.27. It can be placed into a box as on pic.3.21-c, except the box should be bigger, in order for the loudspeaker to.

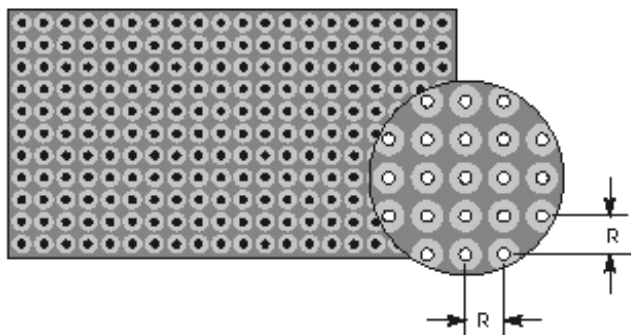

Pic. 5.20 The Universal PCB

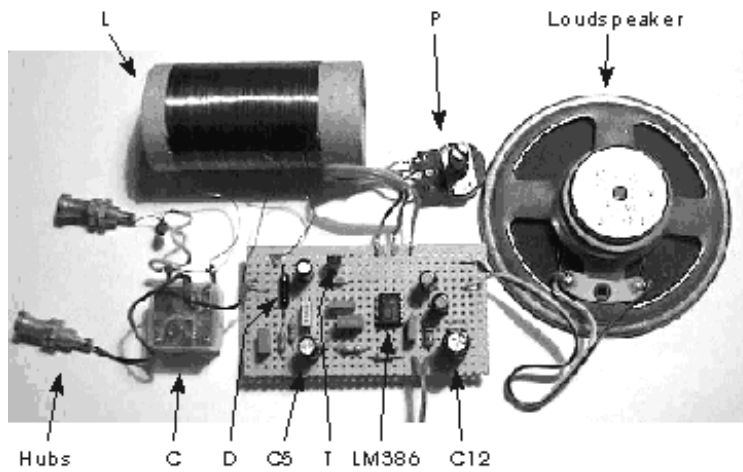

Pic.5.21 The Receiver from pic.3.21-a, mounted on the universal PCB

5.9. A Modern Oldtimer

The receiver on pic.5.22 is designed for the readers that wish to make a semi-conductor model of a complete direct radio receiver that was being produced many years ago, with electronic tubes. It had a total of 3 tubes, one of the contained the HF pentode (utilized in the HF amplifier) and the diode (used in detector), the other one had a triode (pre-amplifier) and powerful pentode (power amplifier), whilst the third one contained the duo-diode (the rectifier).

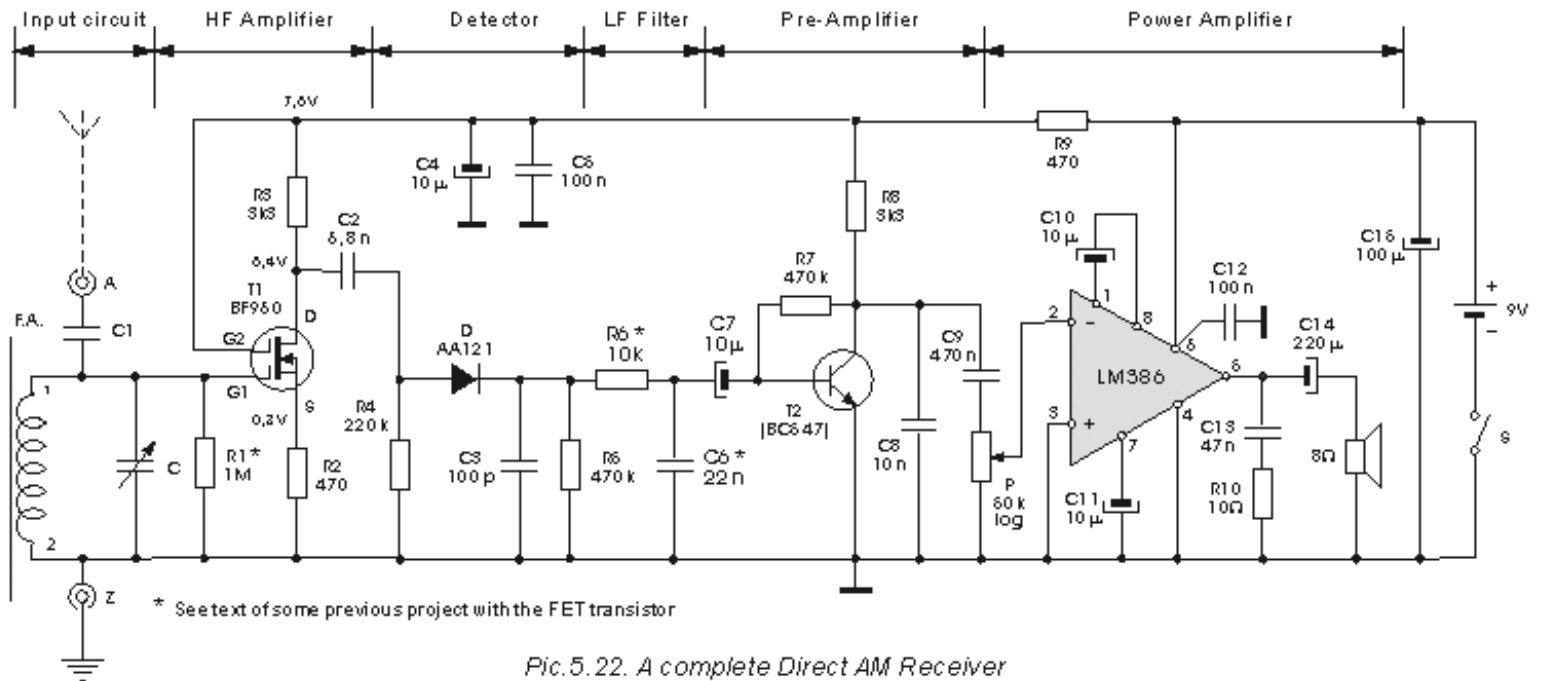

Pic.5.22. A complete Direct AM Receiver

5.5.2. Electronic Tuning

Instead of the capacitor CR, that was used for fine tuning in the previous project, a capacitive (varicap) diode can be used. It's a special HF diode which is polarized by exposing it to DC voltage in order to be non-permeable (+ to the anode, - to cathode). By changing the voltage diode's capacitance also changes, which allows for it to be utilized as variable capacitor. If, acc. to pic.5.13-a, the DC voltage between the cathode and anode (UAK) varies from U1 to U2, diode's capacitance goes from Cmax till Cmin.

The electronic diagram for the electronic fine tuning circuitry is given on pic.5.13-b. Diode capacitance is changed by moving the slider of the P1 potentiometer. By means of trimmer TP the necessary Cmax is set, and when this is done TP can be replaced by an ordinary resistor. All the components are mounted on the PCB, together with other parts of the receiver, except the P1. It is mounted on the front panel, and connected to the PCB with 3 ordinary wires.

* The variable capacitors that were used for tuning in all the receivers described so far are solid, lasting, reliable

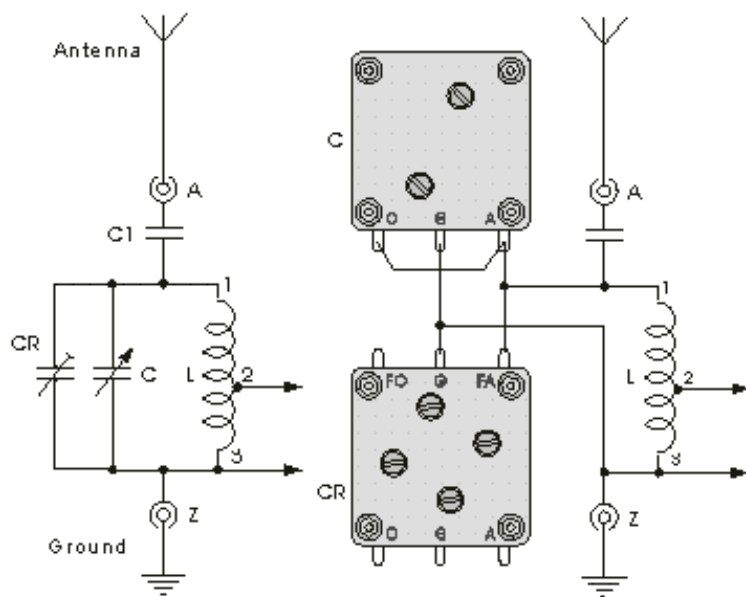

Pic.5.12. Fine Tuning
(stretching a part of the bandwidth)

components. Their mishap is they are hard to purchase, they are quite robust (compared to other device components), and their mounting isn't simple because the shaft for the knob must go through the front plate of the device box. That is why varicap diodes are also replacing them. With the diode that has Cmax/Cmin ratio that is big enough, say, $C_{max}/C_{min} > 15$, the circuit form pic.5.13 can be used as the variable capacitor (C is simply omitted). In that case, some bigger knob with an arrow is mounted on the P1 handle, and numbers from 1 to 10 are written on the panel, as shown on pic.5.13. This scale allows the listeners to see what station is the receiver tuned at. Of course, for the MW band, the numbers as those on pic.3.7 can also be written.

* In case of SW band, the P2 potentiometer is added for fine tuning.

The optical indication of the tuning, with and knob with arrow is the simplest solution possible. More prettier one is using a small movable-coil instrument (V), such as those used as battery indicators in industrial devices, or for tuning indication and similar. The connecting is done acc. to the diagram on the left part of the pic.5.13-c. In series with the instrument, the TP potentiometer is attached. Its resistance depends on the maximum instrument current, and can be found experimentally. For start, you may use a 1 MOhm linear trimmer, with its slider at lowest position (so that its resistance is maximum). Put the P1 slider also at the lowest position. Turn on the receiver. Start moving the P1 slider upwards, and observe the instrument needle. If it soon goes to the end, you'll have to take a trimmer with greater resistance or to add another resistor in series with it, so that when the P1 slider gets to its rightmost position, the needle goes somewhere around the middle of the full scale. If the needle, with P1 in topmost position, moves too little, you'll need a smaller resistance trimmer. When you succeed in having the needle in the middle of the scale with P1 in topmost position, start moving the TP slider until the needle reaches the end of scale. The circuit is well adjusted if the needle goes from zero to full scale while P1 slider is moved from bottommost to topmost position. The instrument can have any shape, but the most appropriate (and cheapest) is square, like the one on the picture.

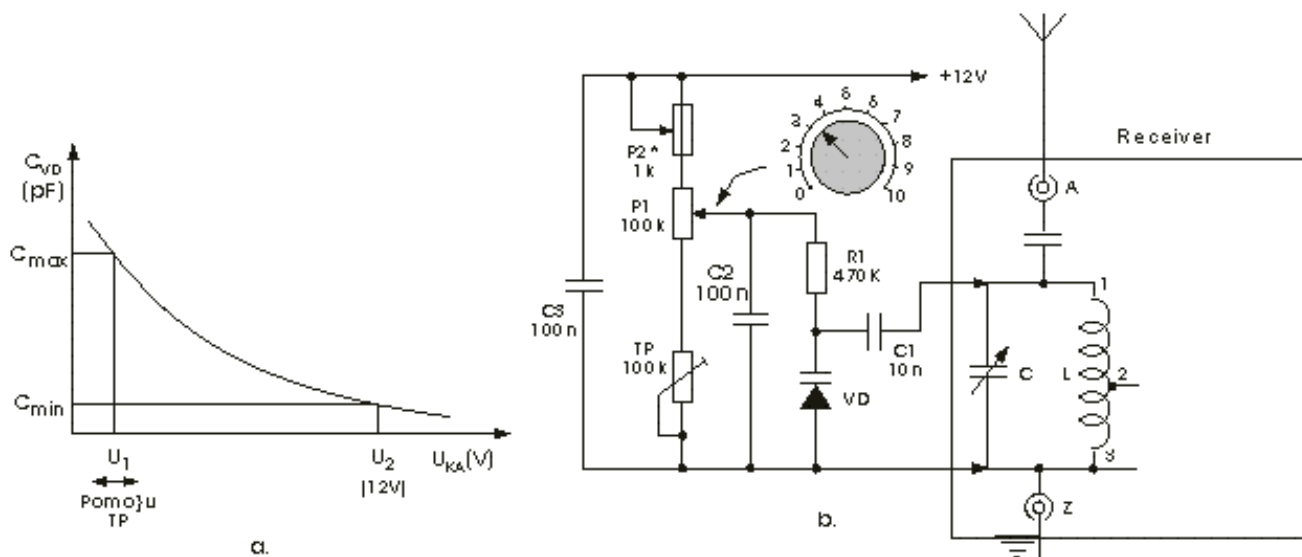
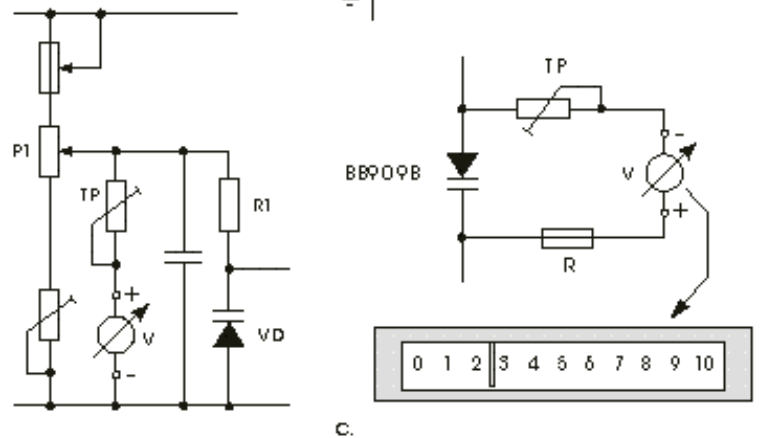

Fig. 5.13. Electronic Tuning: a-Diagram, b-Varicap Diode Characteristic, c-Receiver Scale

* The optical indication of station tuning at the receiver with electronic tuning, as those on pics. 4.12, 4.14 and 4.19 is accomplished with the instrument that is connected in parallel to the varicap diode. The diagram is shown on the right part of pic. 5.13-c. In the lower part of the picture the movable-coil instrument is shown.

Scales of these instruments are most often marked from 1 to 10, but, if you are skilful enough, you can write down numbers representing frequencies in MHz (e.g. 88...96...100...108 MHz).



5.5.3. Suppressing the Signal of the Local Transmitter

From all the signals in the reception antenna, the one that is created by the local transmitter is by far the strongest one, due to the fact that it is hundreds, sometimes even thousands times closer than other radio transmitters. That signal can be so strong that it can jam normal reception of other stations. In case of simpler receivers its programme is heard, more or less, in all the positions of the variable capacitor. The solution for this problem is the so-called seal circuit, which serves to weaken the signal of the local transmitter, so that it doesn't interfere (but is still strong enough for normal reception, when the receiver is tuned at it).

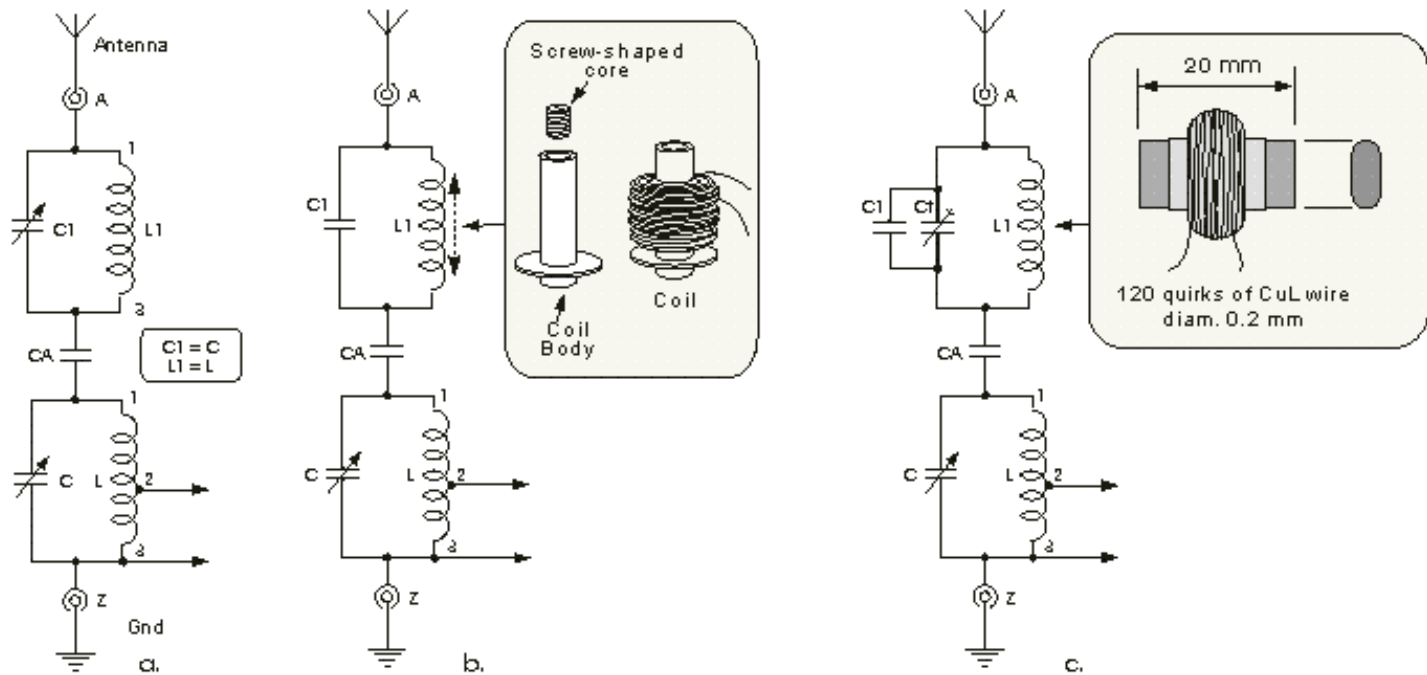

Pic. 5.14 . Suppressing the Signal of the Local Transmitter

The seal circuit is a parallel oscillatory circuit which comprises the coil L1 and capacitor C1, as shown on pic.5.14-a. By means of C1 the resonance frequency of the circuit is set so that it corresponds to the carrier frequency of the local station. On that frequency, this circuit behaves as a huge resistor (see pic.3.2-b) and decreases the current that is created by the local transmitter signal. For other signals it has very small resistance and practically has no effect on them. The setup is done by tuning the receiver on the local station, and the reception is weakened enough by turning the C1. If the decay is too strong, a resistor should be added in parallel to C1.

Using a variable capacitor in the seal circuit (pic.5.14-a) isn't an economical solution. It is much better, considering both economy and space, the solution given on pic.5.14-b. A block capacitor C1 and a variable inductance coil are used in the seal circuit. As shown on the framed part of picture, the coil is wound on the plastic body, with ferrite core. The number of quirks is found experimentally about couple of hundreds of quirks made with as thin copper wire as possible). The capacitance for C1 is also found experimentally (couple of hundreds of pF). The earlier mentioned IF transformer can also be used as a coil. With labelling acc. to pic.4.3-a, legs No.2 and 3 are used, the others are "hanging" (they are not soldered). C1 capacitance is also found experimentally. It is also possible to wind the coil on a piece of ferrite rod, as shown on pic.5.14-b, and setup to be done with trimmer Ct

5.5.4. Dual Tuning

The author of this book, as great radio technique lover (amateur, in French), owns great collection of over 150 pieces of various old-timer radio receivers. There is one among them that is over 60 years old, at which the tuning is being done by two knobs. With first one the receiver is set roughly to the desired station, which is usually barely heard at that moment. The second knob is then turned until the optimum reception is achieved, which is significantly better than before, and in case of weak stations - extremely better.

The selectivity of simple receivers that were described in previous chapters can be significantly increased by using the aforementioned dual tuning. The electronic diagram is shown on pic.5.15-a. Another oscillatory circuit, made of L1 and C1 connected in series, is inserted between the antenna connector and input circuit of the receiver (it can be any of the earlier described AM receivers). As with the earlier mentioned parallel oscillatory circuit, the resonance frequency of the serial circuit is given by the Thompson pattern:

$$f_r = \frac{1}{2\pi\sqrt{LC}}$$

The serial oscillatory circuit has very small impedance (compared to the parallel circuit whose impedance is very big on the

resonance frequency). The dependance of the impedance ("resistance") of the serial oscillatory circuit from the frequency is shown on the diagram on pic.5.15. As you can see, the serial circuit acts as a resistor of very small impedance only for the station that it's tuned at. For all other stations, it behaves as a huge resistor (impedance). All in all, from all the signals in the antenna, the biggest current, and therefore the biggest voltage on the input circuit is created by the transmitter that both serial and parallel oscillatory circuits are set to. The tuning is done as it has already been described, first with C (so-so), then with C1 (much better).

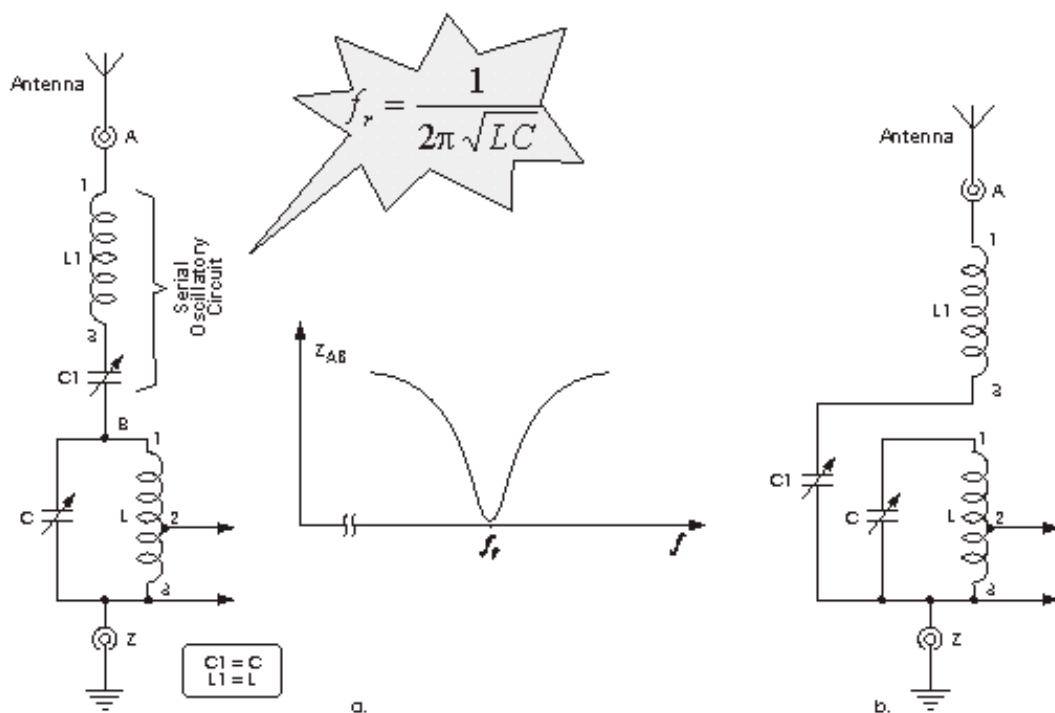

Pic.5.15. Dual Tuning: First by C (so-so), then by C1 (much better)

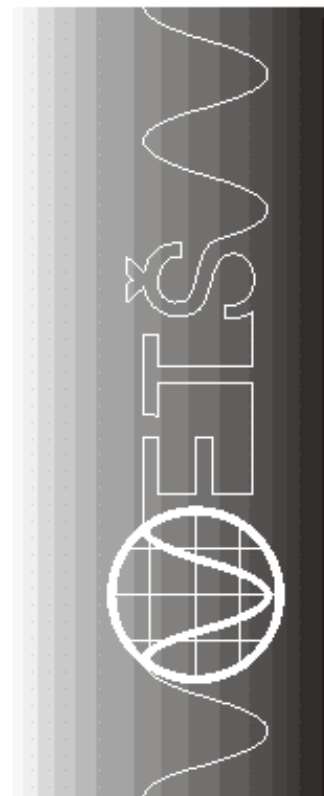

* Between the coils L1 and L a magnetic coupling should be prevented. This is accomplished by mounting the coils to be as far from each other as possible, and to position their axes mutually perpendicular.

* Greater experimenting opportunities with dual tuning provides the diagram on pic.5.15-b. Once again, it's the serial resonance (in circuit L1, C1), and parallel resonance (in circuit L, C), that are being used. The coils are placed side-by-side, in order to generate magnetic coupling between them. The tuning is done as previously explained, but now we also have a possibility of changing the amount of magnetic coupling between the coils by moving them closer or farther, which affects the antenna's influence on the L, C oscillatory circuit, therefore changing its selectivity and sensitivity.

5.5.5. Separation of Stages - Preventing the Oscillation

One of the significant problems that occur at devices that comprise more cascade-linked amplifying stages is the occurrence of the feedback over the conductors that connect those stages with the positive pole of the battery, or the power supply. By the way, the feedback is a phenomenon when part of the signal exiting an amplifier gets on its input. Under certain conditions, this feedback causes the oscillation of the stage, which in devices that have the loudspeaker on output, manifests itself as strong whistling, squeaking and similar.

One of the ways to prevent this feedback is given on pic.5.16, where a block-diagram of a radio receiver that has four amplifying stages with active components (transistors or IC's) that require the battery supply is shown. Separation of stages for the AC current (preventing the feedback) is accomplished by the LF filters with resistors and capacitors. Resistors are from couple of hundreds of Ohms to 1 kOhm. Capacitances of C1 and C2 are from couple of tenths till couple of hundreds of nF, and of C3 from couple of hundreds of nF to about 100 mF. The stage PCBs should be designed in such way to make the contact where right end of the capacitor is soldered as close to the contact where the positive end of the power supply voltage is brought (e.g. on pic.5.9, the right contact for C6 should be as close as possible to the contact where pin 8 of NE612 is soldered).

In the devices supplied from the battery, the C5 capacitor, which has capacitance of couple of hundreds of micro Farads, serves to take the role of the battery when it gets emptied a little bit, and strong tones have to be reproduced at the

loudspeaker (in simple terms, C5 acts as a small accumulator that helps the worn-out battery to give enough power to the power amplifier, when necessary. When its help isn't needed, the capacitor is recharged). This capacitor is not needed when the receiver is supplied from the adaptor that already has an electrolytic capacitor on its output, and when the wires that connect the adaptor to the receiver are not longer than about 15 cm.

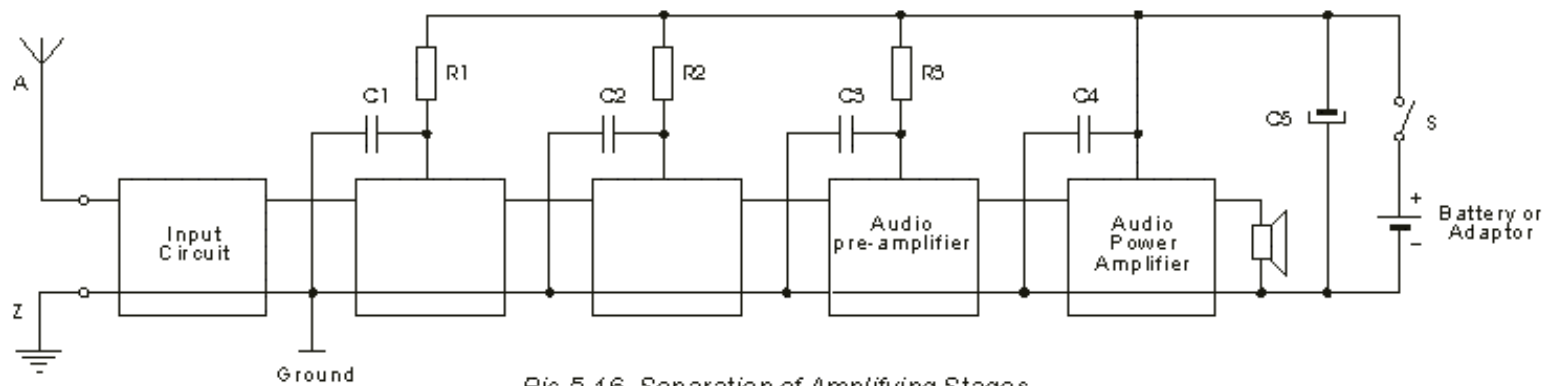

Pic.5.16. Separation of Amplifying Stages